

Baldwin[®]

Pianos



Organs

TECHNICAL MANUAL

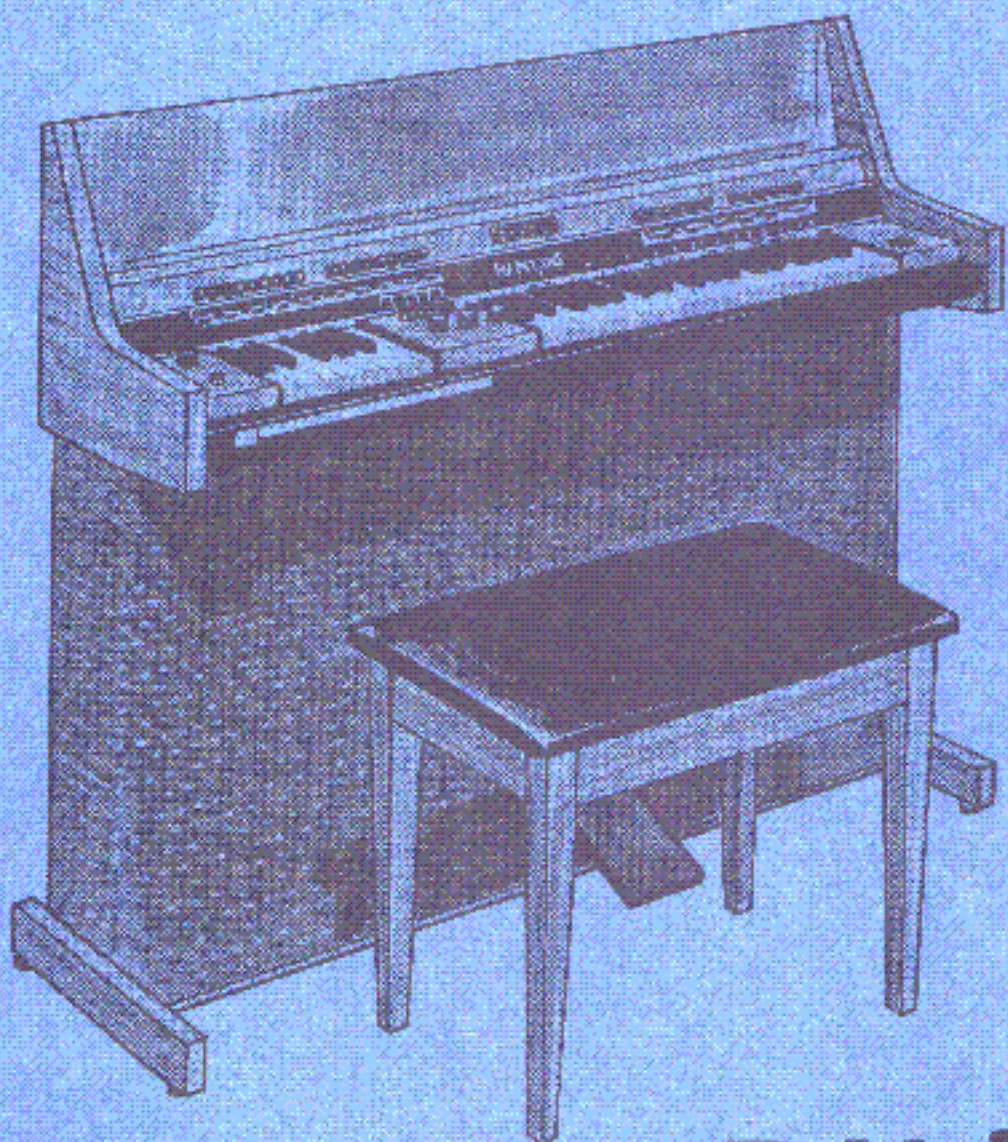

Baldwin[®] FUNMACHINE[®]

Reprinted October 1979



Baldwin®

Pianos



Organs

TECHNICAL MANUAL

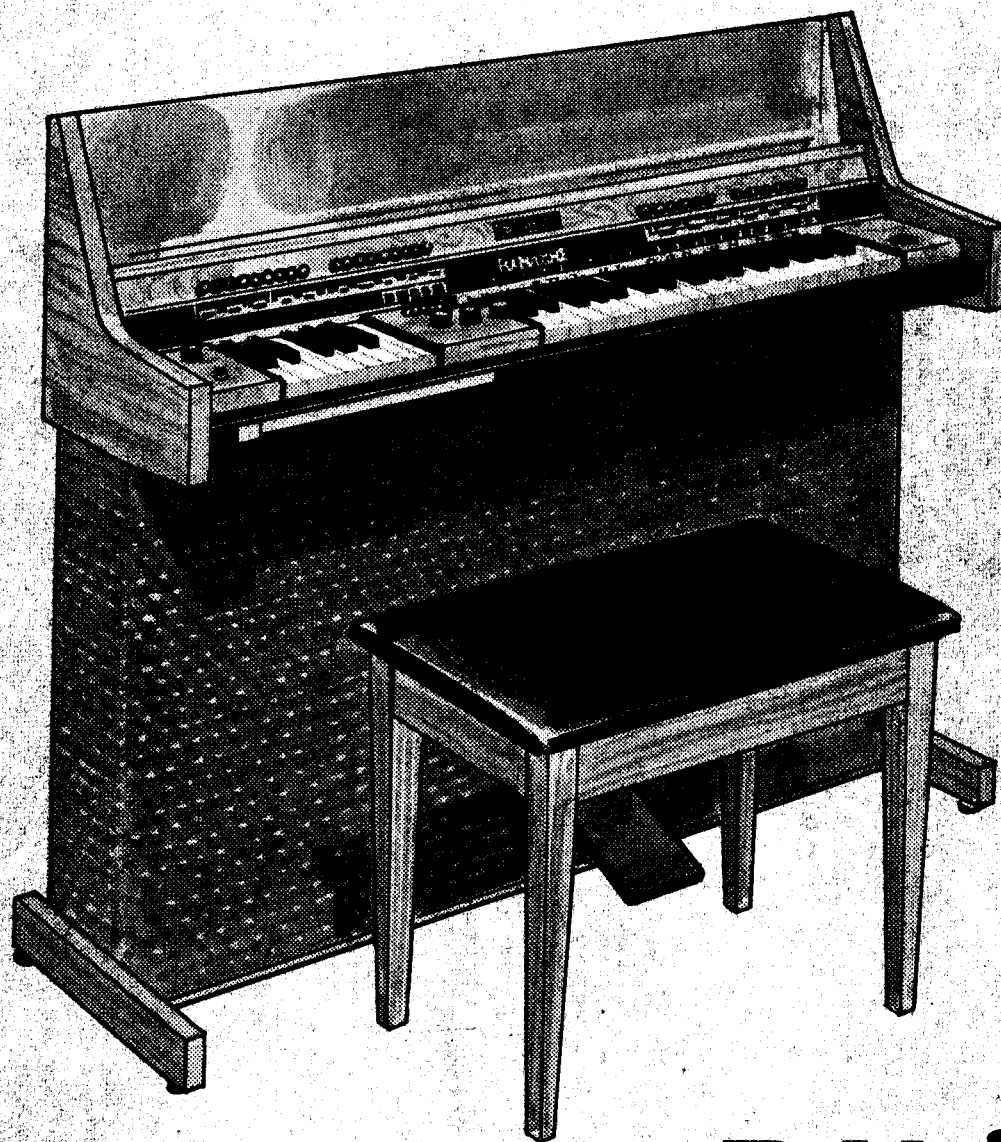

Baldwin® FUNMACHINE®

Reprinted October 1979

Baldwin Piano & Organ Company 1801 Gilbert Avenue, Cincinnati, Ohio 45202 (513) 852-7000

Musical Instruments by



T E C H N I C A L M A N U A L

M O D E L 1 2 1 S E R I E S O R G A N

I N D E X

PAGE	FIGURE
1.....Fun Machine Specification	
2.....Volume Level Setting Procedure	
3.....Organ Front View - Photo	1
4.....Description Fig. 1	
5.....Fun Machine Control Panel - Photo & Description	2
6.....Back Panel Removed - Photo & Description	3
7.....121 Organ Rear View (Back Panel Removed) - Photo	4
8.....Description Fig. 4	
9.....Fun Machine Boards Assembly - Photo & Description	5
10.....Control Panel Raised - Photo & Description	6
11.....Underneath the Manual View - Photo & Description	7
12.....Major/Minor Switch Assembly - Photo & Description	8
13.....Center Keycap Assembly - Photo	9
14.....Description Fig. 9	
15.....Fluorescent Light Mounting - Photo & Description	10
16.....Keybed - 4 Keys Removed - Photo & Description	11
17.....Key Assemblies - Photo & Description	12
18.....Disassembly Procedure	
20.....Keyswitch Wiring Diagram - Pictorial	
21.....Top Octave Frequency Generator (T.O.F.G.) & Diode Gate Theory	
23.....Fun Machine Frequency Generation & Distribution Diagram	
24.....T.O.F.G. Board Wiring Diagram - Pictorial	
25.....T.O.F.G. Schematic Diagram	
26.....T.O.F.G. Board Assembly - Pictorial	
27.....Gate & Divider Board Assembly - Pictorial	
28.....Gate & Divider Board Schematic Diagram	
29.....Gate & Divider Board Wiring Diagram - Pictorial	
30.....Fun Machine General Theory	
40.....Rhythm Counting Sequence Chart	
41.....Rhythm Waveform Chart	
46.....Diode Matrix Chart	
48.....Fun Machine Rhythm Pattern & Voice Selection Chart	
49.....Fun Machine Rhythm Master Pattern Chart	
50.....Fun Machine Transistor Function Chart	
53.....Fun Machine Block Diagram	13
54.....Key Selector Keycap Wiring Diagram - Pictorial	
55.....Control Panel Wiring Diagram - Pictorial	
56.....Fun Machine Logic Board Assembly - Pictorial	
57.....Fun Machine Logic Board Schematic Diagram	
58.....Fun Machine Logic Board Wiring Diagram - Pictorial	
59.....Right Hand Board Wiring Diagram - Pictorial	
60.....Right Hand Board Schematic Diagram	
61.....Right Hand Board Assembly - Pictorial	
62 & 62A.....Rhythm Section Board Assembly - Pictorial	
63.....Rhythm Section Board Schematic Diagram	
64.....Rhythm Section Board Wiring Diagram - Pictorial	
65.....Power Supply, Amp., AC & DC Wiring Diagram - Pictorial	
66.....Preamplifier and Expression Control Theory	
67.....Preamplifier Board Wiring Diagram - Pictorial	
68.....Preamplifier Board Schematic Diagram	
69.....Preamplifier Board Assembly - Pictorial	
70.....Expression Pedal Assembly - Pictorial	
71.....Power Supply Theory	
72.....Power Supply View - Photo & Description	14
73.....Power Supply Board Wiring Diagram - Pictorial	
74.....Power Supply Schematic Diagram	
75 & 75A.....Power Supply Board Assembly - Pictorial	
76.....Power Amplifier Theory	
77.....Power Amplifier Schematic Diagram	
78.....Power Amplifier Board Assembly - Pictorial	15
<u>M O D E L 1 2 1 W S U P P L E M E N T</u>	
79.....121 W General Information	
80.....Photo - Control & Keyboard - 121W	16
81.....Photo - 121W Rear	17
82.....Photo - 121W Fun Machine Boards	18
83.....Power Supply & Amp. DC Wiring Diagram	
83-1.....T.O.F.G. Board Assembly - Pictorial	
83-2.....Gate & Divider Board Assembly - Pictorial	
83-3.....Gate & Divider Board Pin Wiring Diagram	
83-4.....Block Diagram - 121	18A
83A.....Fun Bass Theory	

PAGE	FIGURE
84.....	Schematic, Keycap
85.....	Rhythm Voice Board Wiring Diagram
86.....	Rhythm Voice Board Assembly
87.....	Rhythm Voice Board Schematic
88.....	Right Hand Voice Board Assembly
88A.....	Right Hand Voice Board Pin Wiring Diagram - Revised
88B.....	Right Hand Voice Board Assembly - Revised
89.....	Right Hand Voice Board Schematic
90.....	Right Hand Voice Board Wiring Diagram
91.....	Fun Maching Logic Board Wiring Diagram
92.....	Fun Machine Logic Board Schematic
92A.....	Fun Machine Logic Board Assembly - Revised
93.....	Fun Machine Logic Board Assembly
93A.....	Touch Strip Board Assembly
94.....	Preamp Board Wiring Diagram
95.....	Preamp Board Schematic
96.....	Preamp Board Assembly
97.....	25W Amp Board Assembly
98.....	25W Amp Board Schematic
99.....	25W Amp Board Trouble Shooting

APPENDIX

a.....Parts List

INDEX OF DRAWINGS IN NUMERICAL ORDER

DRAWING	PAGE	
B501-060132.....	Keyswitch Wiring Diagram	20
-060448.....	Preamplifier Board Wiring Diagram	67
-060448A.....	Preamplifier Board Wiring Diagram (121W)	94
-060604.....	Power Supply Board Wiring Diagram	73
-060641.....	T.O.F.G. Board Pin Wiring Diagram	24
B505-100446.....	25W Amplifier Board Trouble Shooting (121W)	99
C500-060447.....	Preamplifier Board Assembly	69
-060447D.....	Preamplifier Board Assembly (121W)	96
-100615.....	Touch Strip Board Assembly	93A
-102975.....	25W Amplifier Board Assembly	97
C501-051929.....	Power Amplifier Schematic	77
-060131.....	Gate & Divider Board Wiring Diagram	29
-060143.....	Gate & Divider Board Schematic	28
-060320.....	Preamplifier Board Schematic	68
-060320B.....	Preamplifier Board Schematic (121W)	95
-060331.....	Key Selector Keycap Wiring Diagram	54
-060471.....	Rhythm Section Voice Board Wiring Diagram	64
-060480.....	Fun Machine Logic Board Wiring Diagram	58
-060598.....	Power Supply Schematic	74
-060664.....	Right Hand Board Wiring Diagram	59
-100455.....	25W Amplifier Schematic (121W)	98
-100992.....	Right Hand Voice Board Wiring Diagram	88A
-103070.....	Rhythm Voice Board Wiring Diagram	85
-103354.....	Right Hand Board Pin Wiring Diagram	90
-103527.....	Gate & Divider Board Pin Wiring (121W)	83-3
C579-412.....	Fun Machine Frequency Generation & Distribution Diagram	23
D500-053250.....	Expression Pedal Assembly	70
-060130.....	Gate & Divider Board Assembly	27
-060470.....	Rhythm Section Voice Board Assembly	62
-060479.....	Fun Machine Logic Board Assembly	56
-060603.....	Power Supply Board Assembly	75
-060640.....	T.O.F.G. Board Assembly	26
-060663.....	Right Hand Voice Board Assembly	61
-102983.....	T.O.F.G. Board Assembly (121W)	83-1
-103352.....	Right Hand Voice Board Assembly (121W)	88B
-103520.....	Gate & Divider Board Assembly (121W)	83-2
D501-060267.....	Control Panel Wiring Diagram	55
-060673.....	T.O.F.G. Schematic	25
-060689.....	Power Supply, Amp., AC & DC Wiring Diagram	65
-060689C.....	Power Supply, Amp., AC & DC Wiring Diagram (121W)	83
-100945.....	Fun Machine Logic Board Wiring Diagram (121W)	91
-101412.....	Key Selector Keycap Schematic (121W)	84
D579-410A.....	Fun Machine Rhythm Master Pattern Chart	49
-411.....	Rhythm Logic Waveform Chart	41
R500-100231.....	Rhythm Voice Board Assembly (121W)	86
-100766.....	Fun Machine Logic Board Assembly (121W)	93
-102979.....	Fun Machine Logic Board Assembly (121W)	82A
-103072.....	Rhythm Voice Board Assembly (121W)	86A
R501-060567.....	Rhythm Section Voice Board Schematic	63
-060575.....	Fun Machine Logic Board Schematic	57
-060699.....	Right Hand Voice Board Schematic	60
-060699J.....	Right Hand Voice Board Schematic (121W)	89
-100461.....	Rhythm Voice Board Schematic (121W)	87
-100779.....	Fun Machine Logic Board Schematic (121W)	92

FUNMACHINE

by Baldwin

If you and your family have been listeners all your lives, turn off the stereo. And turn on to a whole new world of fun and creativity with the remarkable FunMachine.

You'll make music the first time you try.

With only one finger, you'll start a marching band marching. Or, lead a different band to suit your musical taste. From Ragtime to Rhumba. From Polka to Pop Rock.

NOW FOR THE OTHER HAND.

With only one finger, play a trumpet in your living room. Or, select from a variety of solo instruments. From Vibra Harp to Harpsichord. From Banjo to Piano.

NOW, GET IT TOGETHER.

With just two fingers, you can play a melody and have a full band backing you up. Even if you've never played a musical instrument, you'll quickly play the FunMachine.

FunMachine is the ideal way to give your family some enjoyable musical experience. And it's the ideal way to bring your family together with something they can all have fun doing.

Although the FunMachine is fun from the start, it is versatile enough to keep on being fun...even after you become a much better player. You'll start playing in practically no time, but you won't stop discovering new FunMachine sounds for years.

Put the FunMachine in your home, and you'll put more fun into your life. You and your family will make music happen, instead of letting it happen to you.

SPECIFICATIONS:

RHYTHM SECTION

Rhythms - A full rhythm section includes a bass guitar, piano, a banjo and a complete drum section. Automatically plays your choice of 17 individual rhythms. You can also try them in combination.

Fox Trot	Pop Rock	Polka
Swing	Soul Rock	March
Dixieland	Hawaiian	Old-Time Waltz
Ragtime	Latin III	Waltz
Country	Rhumba	Organ
Hoe-Down	Bossa-Nova	

Touch Rhythm/Continuous Rhythm - With Touch Rhythm, the FunMachine Rhythm Section follows you - it plays when you play. With Continuous Rhythm, you follow the FunMachine Rhythm Section - you play when it plays.

Key Selector - The six Key Selector buttons automatically program the six right chords for the scales of all twelve keys. They allow you to play the right chords for any song in any key, with just one finger - a Baldwin exclusive!

SOLOISTS

Solo Voices - Eight different solo voices play the melody. Like the rhythms, they may be used individually, or combined for new and exciting sounds!

Flute	Guitar
Accordion	Piano
Trumpet	Harpsichord
Vibra Harp	Banjo

ASR (Automatic Solo Registration) - Another Baldwin exclusive! ASR automatically programs an appropriate solo instrument for each of the seventeen rhythms. Select the rhythm you want, and FunMachine will do the rest.

Auto-Mute - Automatically mutes your solo instrument to create a new and exciting instrumental effect from a wah-wah muted brass to a synthesizer sound.

Percussion Patterns I and II - Pattern I continuously repeats solo percussion sounds in time with the Rhythm Section. Pattern II provides a different solo percussion pattern for each of the seventeen rhythms in the left-hand Rhythm Section.

OTHER CONTROLS

Tempo - Regulates the speed of the rhythm.

Downbeat Indicator Light - Automatically flashes at the downbeat or first beat of every measure.

Drum Balance - Adjusts the volume balance between the orchestral voices in the Rhythm Section and the drums. If you wish, sounds can be cancelled completely.

Vibrato - The distinctive wavering effect creates special effects like a Hawaiian Guitar.

Minor Bar - Automatically changes chords from major to minor.

Volume Pedal - This convenient foot control regulates the overall volume level of FunMachine.

Off-On Switch - When FunMachine is turned on, an illuminated control panel shows you the names of the controls and the notes.

GENERAL DESCRIPTION

Amplification - Single-channel, 25-watt (rms) transistorized system with 12-inch speaker plus 6-inch tweeter with crossover.

Keyboard - 13-note Rhythm Section keyboard and 37-note Soloist keyboard.

Dimensions - Depth 14-1/2" (36.8 cm), Width 43-1/2" (110.5 cm), Height 37" (94 cm).

Weight - 85 pounds (38.56 kg).

Headphone Jack - Under left side of keyboard.

Cassette Tape Player/Recorder - Optional - factory installed.

VOLUME LEVEL SETTING PROCEDURE

FOR MODEL 121 SERIES ORGAN

1. Depress ORGAN and ASR buttons. Set the DRUM BALANCE control fully counter-clockwise.
2. Expression pedal should be depressed fully down.
3. Play low "C" key in the Rhythm Section (Left Hand) and Middle C, E, G, C chord in the Soloist Section (Right Hand). Keys to be played are indicated with arrows on keyboard illustration below.
4. Set the voltage across the 12" speaker to 4.0 volts.
5. The voltage across the 6" tweeter speaker must be 1.0 to 1.4 volts.

It should be noted that the above level setting will give satisfactory results for most conditions, however, it may be necessary to adjust setting slightly to compensate for individual taste or acoustical environment.

Note: Level set minipot is located on the Preamplifier Board Assembly.

Refer to Fig. 4, Item 25 and Drawing No. C500-060447.

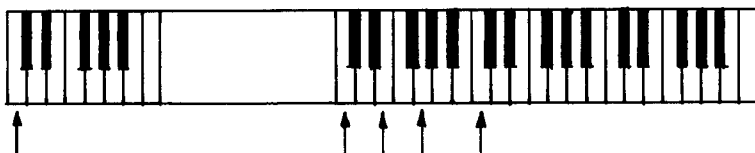

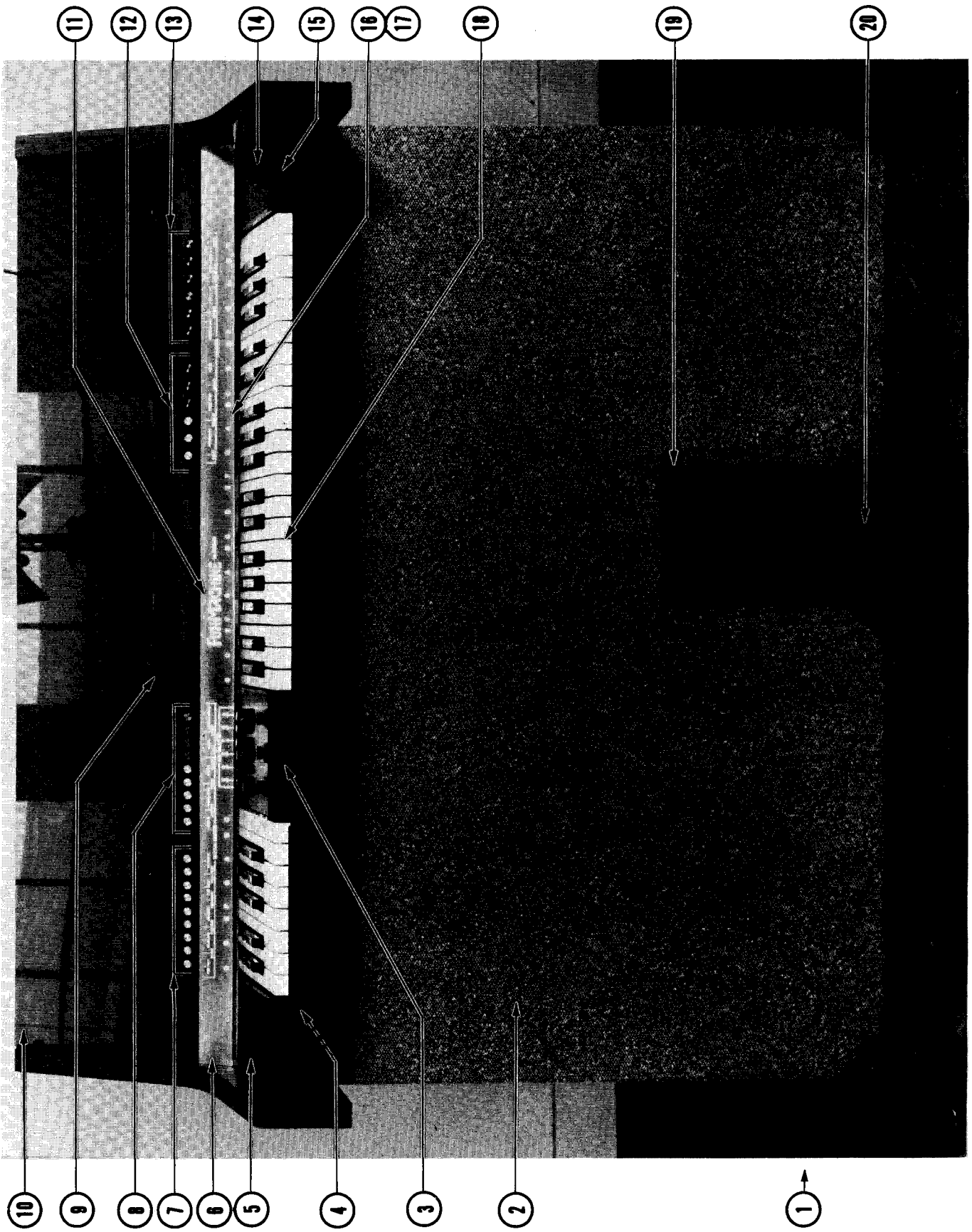

FIG. 1 - ORGAN FRONT VIEW

DESCRIPTION - FIG. 1

ITEM	DESCRIPTION	PART NUMBER
1	BENCH FINAL ASSEMBLY (NOT SHOWN)	C160*60493
2	GRILLE CLOTH	A244-060450
3	CENTER KEYCAP FINAL ASSEMBLY	X500-060086
4	PHONE JAX ASSEMBLY	B500-060236
5	BASS KEYCAP FINAL ASSEMBLY	X500-060085
6	LUMINATE STRIP (FUN MACHINE)	D249-060518
7	RHYTHM SECTION #1 CONTROL SWITCH ASSEMBLY	B500-060163
8	RHYTHM SECTION #2 CONTROL SWITCH ASSEMBLY	B500-060157
9	LID ASSEMBLY	C060*60012
10	MUSIC DESK PANEL	C105-060167
11	CONTROL PANEL & EXTRUSION ASSEMBLY	X500-060175
12	SOLOIST SECTION #1 CONTROL SWITCH ASSEMBLY	B500-060248
13	SOLOIST SECTION #2 CONTROL SWITCH ASSEMBLY	B500-060266
14	POWER SWITCH	A506-058601
15	TREBLE KEYCAP FINAL ASSEMBLY	X500-060084
16	FLUORESCENT LAMP 30W	A514-060528
17	FLUORESCENT LAMP SOCKET (BUTT-ON)	A507-060525
18	MANUAL FINAL ASSEMBLY	X500-060339
19	TRIM MOULDING	A518-052823
20	EXPRESSION PEDAL ASSEMBLY	D500-053250

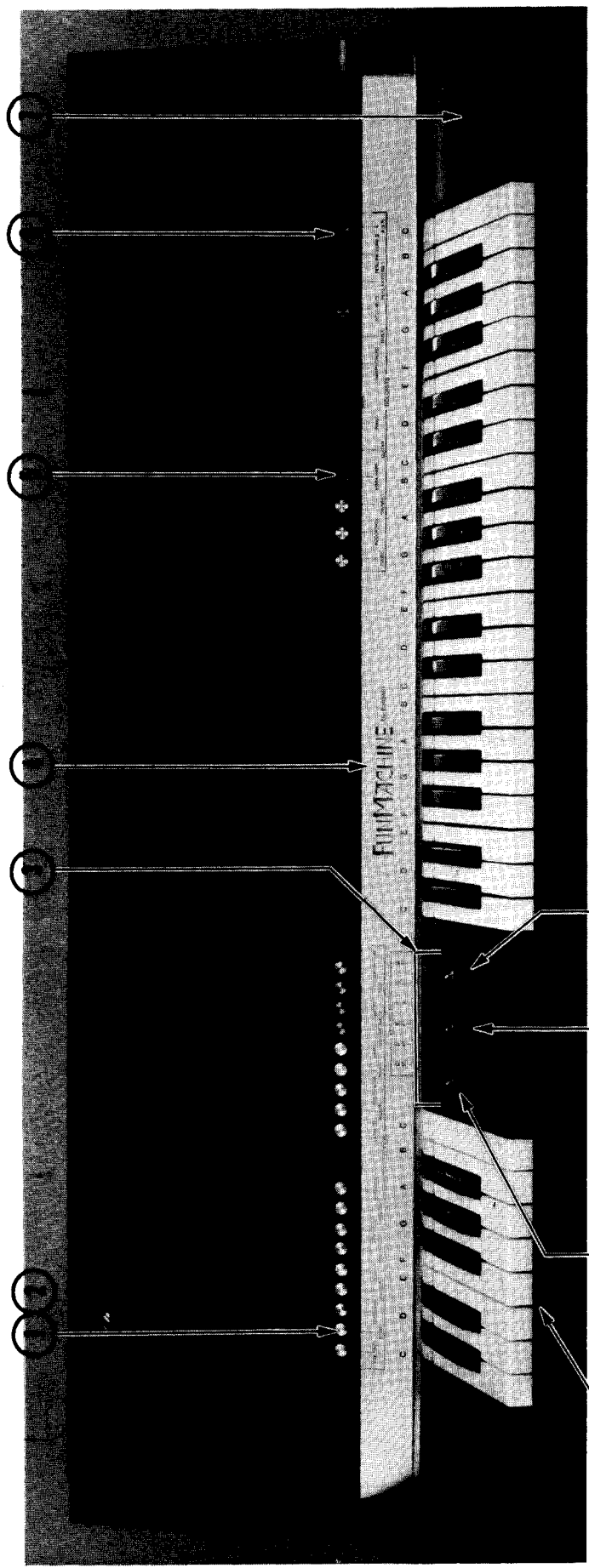

FIG. 2 - FUN MACHINE CONTROL PANEL

ITEM	DESCRIPTION	PART NUMBER
1	PUSH BUTTON	A250-054568
2	PUSH BUTTON INSERT - CLEAR	A247-054869
3	PUSH BUTTON SWITCH - 6 STATION	B506-060078
4	LUMINATE STRIP (FUN MACHINE)	D249-060518
5	PUSH BUTTON INSERT - RED	A247-054868
6	PUSH BUTTON INSERT - BLUE	A247-054867
7	POWER SWITCH	A506-058601
8	NAMEPLATE - "MINOR BAR"	A249-060527
9	KNOB	A247-047794
10	KNOB ASSEMBLY - "TEMPO"	A247-058982
11	KNOB INSERT - "TEMPO"	A249-058946
12	KNOB ASSEMBLY - "DRUM BALANCE, PULL OFF"	A247-060398
13	KNOB INSERT - "DRUM BALANCE, PULL OFF"	A249-060397
14	KNOB ASSEMBLY - "VIBRATO"	A247-060067
15	KNOB INSERT - "VIBRATO"	A249-060065

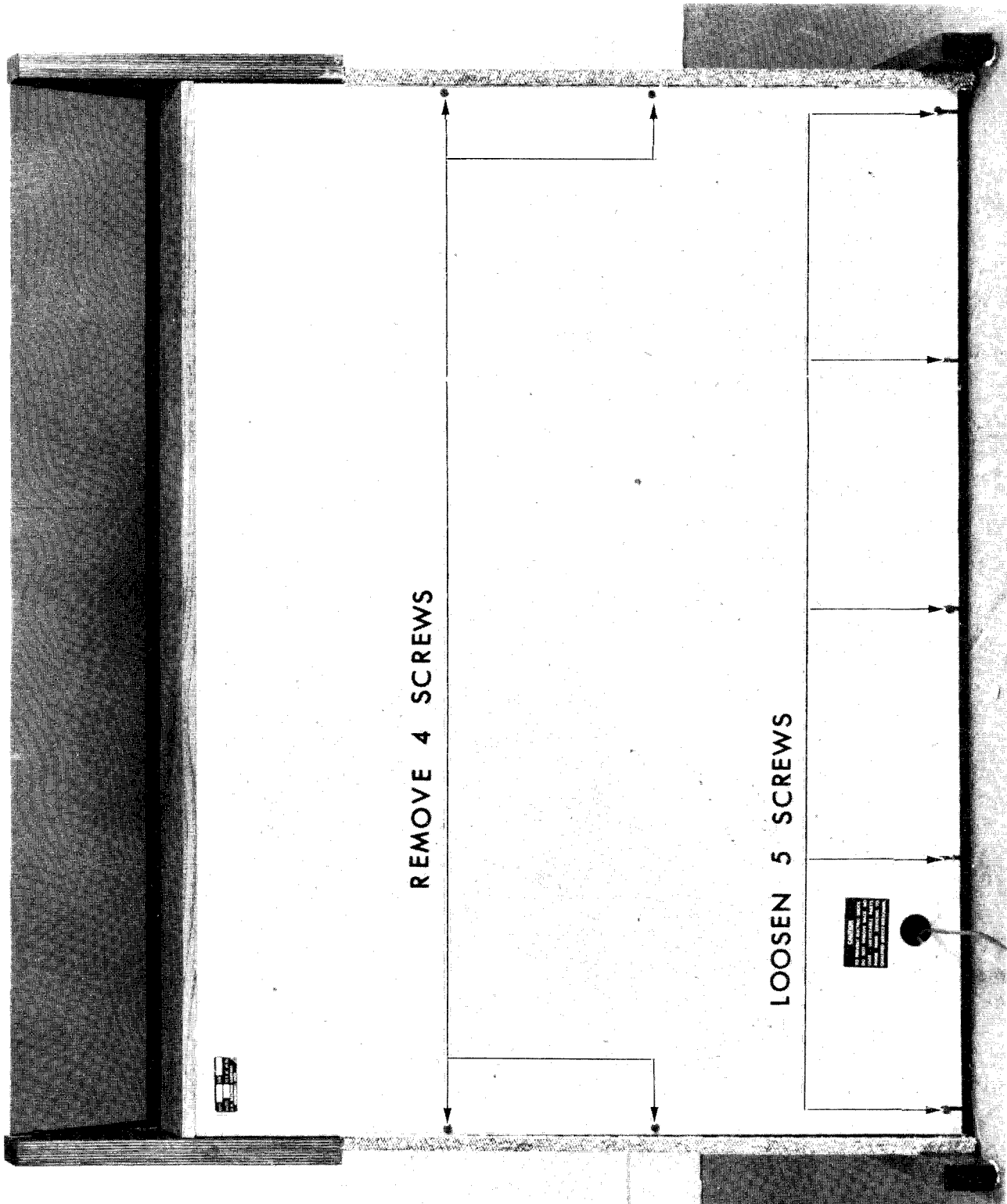

FIG. 3 — BACK PANEL REMOVAL

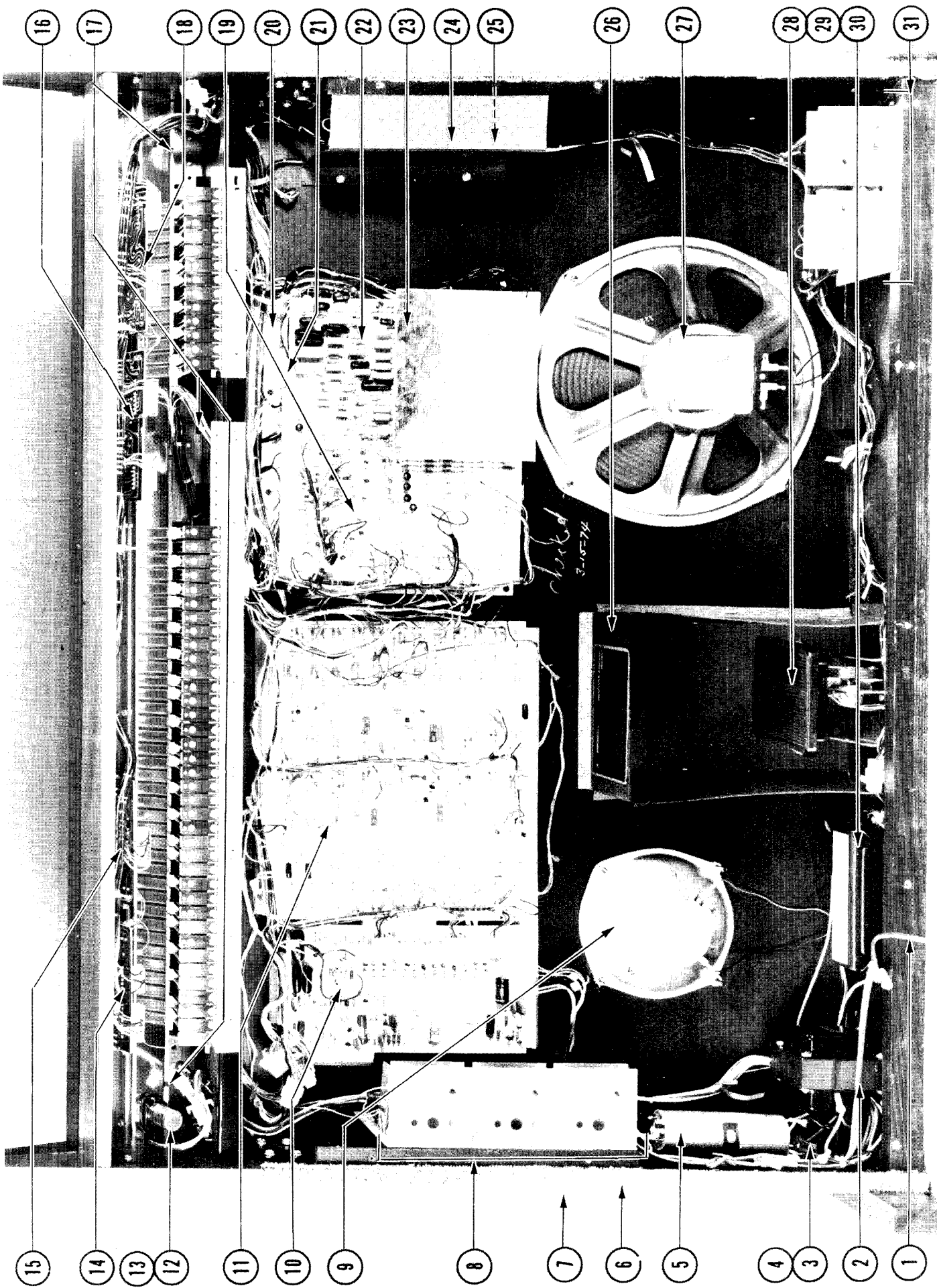

FIG. 4 - 121 ORGAN REAR VIEW (BACK PANEL REMOVED)

DESCRIPTION FIG. 4

ITEM	DESCRIPTION	PART NUMBER
1	POWER CORD	B508-027658
2	TRANSFORMER	C512-053438
3	FUSEHOLDER	A514-059976
4	SLOW BLOW FUSETRON, 2 AMP.	A514-032101
5	CAPACITOR 4000 MFD/60 V	B517-038985
6	GRILLE CLOTH	A244-060450
7	BACK PANEL (NOT SHOWN)	D175-060250
8	POWER SUPPLY BOARD ASSEMBLY	C500-060603
9	SPEAKER 8 OHM, 6"	A513-054664
10	TOP OCTAVE FREQUENCY GENERATOR BOARD ASSEMBLY	B500-060640
11	GATE & DIVIDER BOARD ASSEMBLY	C500-060130
12	FLUORESCENT LAMP STARTER	A514-060529
13	STARTER BASE (SOCKET) 30 W FS-4	A507-060524
14	SOLOIST SECTION #2 CONTROL SWITCH ASSEMBLY	B500-060266
15	SOLOIST SECTION #1 CONTROL SWITCH ASSEMBLY	B500-060248
16	RHYTHM SECTION #2 CONTROL SWITCH ASSEMBLY	B500-060157
17	CONTROL PANEL SECURING SCREWS	
18	RHYTHM SECTION #1 CONTROL SWITCH ASSEMBLY	B500-060163
19	FUN MACHINE BOARDS ASSEMBLY	X500-060698
20	RHYTHM VOICE SECTION BOARD ASSEMBLY	C500-060470
21	FUN MACHINE LOGIC BOARD ASSEMBLY	C500-060479
22	RIGHT HAND VOICE BOARD ASSEMBLY	D500-060663
23	FUN MACHINE SHIELD	B502-060896
24	PREAMP SHIELD	B502-060595
25	PREAMP BOARD ASSEMBLY	C500-060447
26	EXPRESSION PEDAL COVER	B502-060239
27	SPEAKER 8 OHM, 12"	A513-024925
28	EXPRESSION PEDAL ASSEMBLY	D500-053250
29	POTENTIOMETER 50K OHM, 180° LIN. TAPER	B509-048890
30	BALLAST (FLUORESCENT LIGHT)	B514-060522
31	25W AMPLIFIER BOARD ASSEMBLY	B500-060514

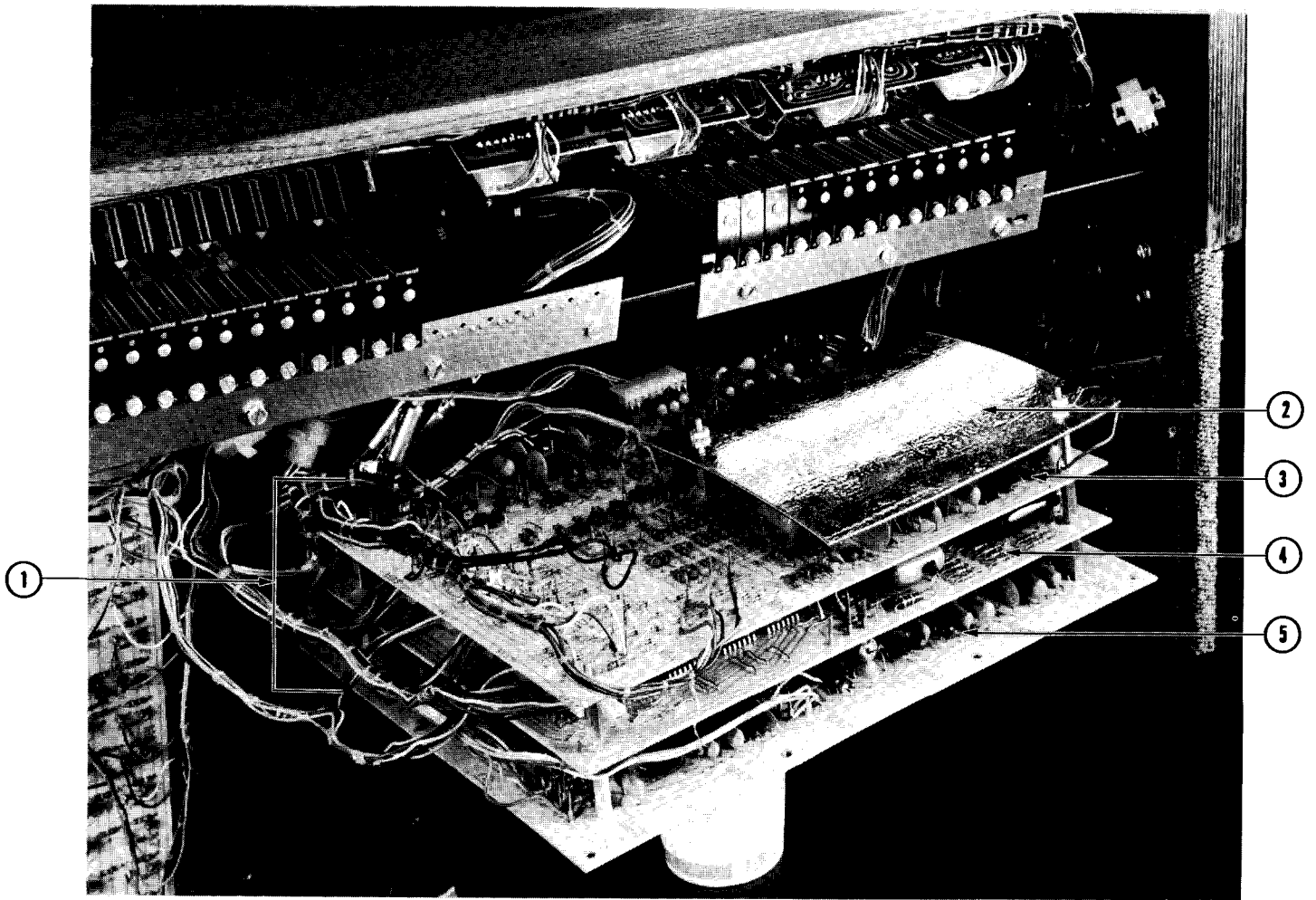

FIG. 5 - FUN MACHINE BOARDS ASSEMBLY

ITEM	DESCRIPTION	PART NUMBER
1	FUN MACHINE BOARDS ASSEMBLY	X500-060698
2	FUN MACHINE SHIELD	B502-060896
3	RIGHT HAND VOICE BOARD ASSEMBLY	D500-060663
4	FUN MACHINE LOGIC BOARD ASSEMBLY	C500-060479
5	RHYTHM VOICE SECTION BOARD ASSEMBLY	C500-060470

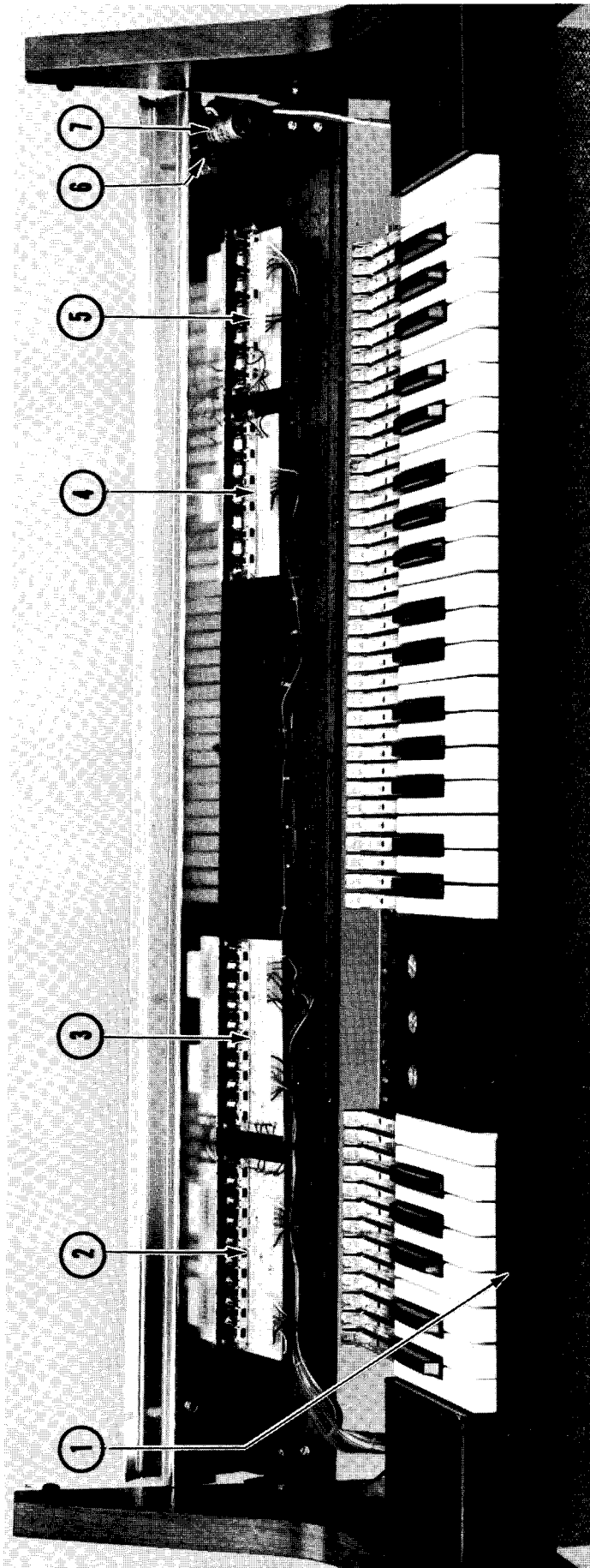

FIG. 6 - CONTROL PANEL RAISED

ITEM	DESCRIPTION	PART NUMBER
1	MAJOR/MINOR BAR AND SWITCH ASSEMBLY	SEE FIG. 8
2	RHYTHM SECTION #1 CONTROL SWITCH ASSEMBLY	B500-060163
3	RHYTHM SECTION #2 CONTROL SWITCH ASSEMBLY	B500-060157
4	SOLOIST SECTION #1 CONTROL SWITCH ASSEMBLY	B500-060248
5	SOLOIST SECTION #2 CONTROL SWITCH ASSEMBLY	B500-060266
6	STARTER BASE (SOCKET)	A507-060524
7	FLUORESCENT LAMP STARTER	A514-060529

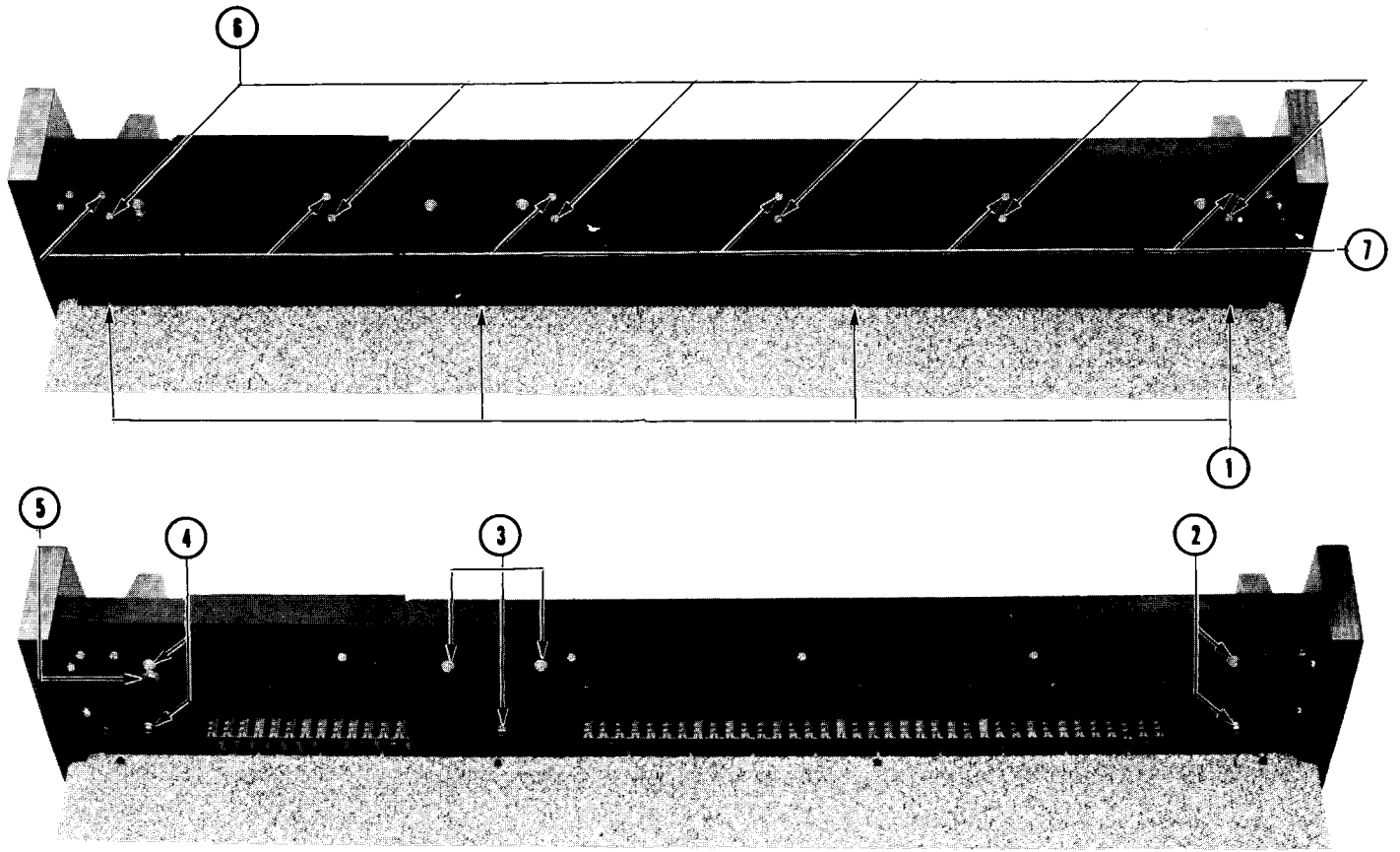

FIG. 7 - UNDERNEATH THE MANUAL VIEW

ITEM	DESCRIPTION	PART NUMBER
1	4 WOOD SCREWS SECURING THE KEYSWITCH COVER TO THE LOWER FRAME	
2	2 SCREWS SECURING THE TREBLE KEYCAP TO THE MANUAL	
3	3 SCREWS SECURING THE CENTER KEYCAP TO THE MANUAL	
4	2 SCREWS SECURING THE BASS KEYCAP TO THE MANUAL	
5	PHONE JAX ASSEMBLY	B500-060236
6	6 SCREWS SECURING THE KEYSWITCH COVER TO THE MANUAL	
7	6 SCREWS SECURING THE MAJOR/MINOR TOUCH BAR SLIP RAIL TO THE MANUAL	

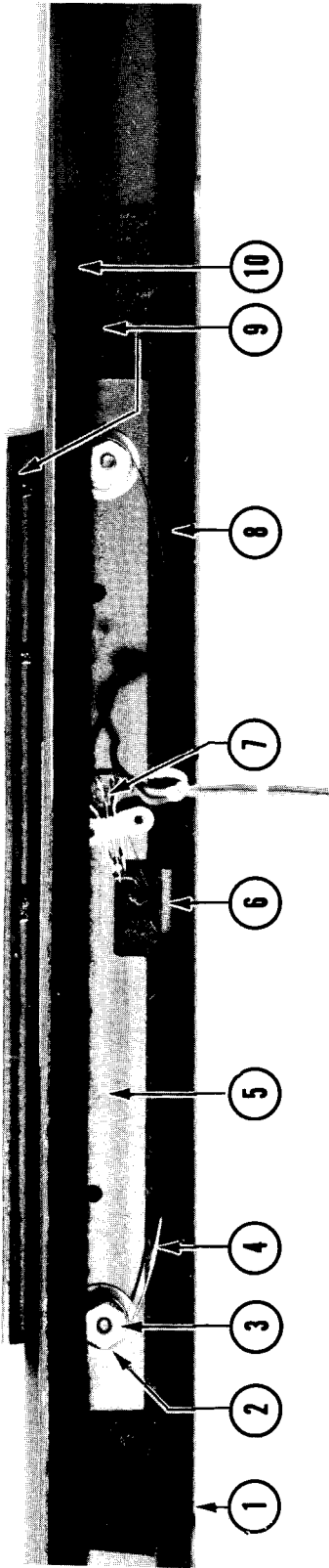

FIG. 8 - MAJOR/MINOR SWITCH ASSEMBLY

ITEM	DESCRIPTION	PART NUMBER
1	ACCOMPANIMENT KEYSLIP WELDED	C500-060142
2	NUT LOCK (6-32)	A247-028484
3	SPEED NUT	A247-052681
4	ACTUATOR DETENT	A237-052680
5	ACTUATOR BAR - RIVETED	B500-052666
6	RUBBER BUMPER	A244-040842
7	MICRO SWITCH	A506-052616
8	FELT 1/8 x 1/2, BROWN	A244-010008
9	FELT MAROON .035/.050 x 1/4	A244-006211
10	FELT MAROON .240/.260 x 5/16	A244-024941

121-2

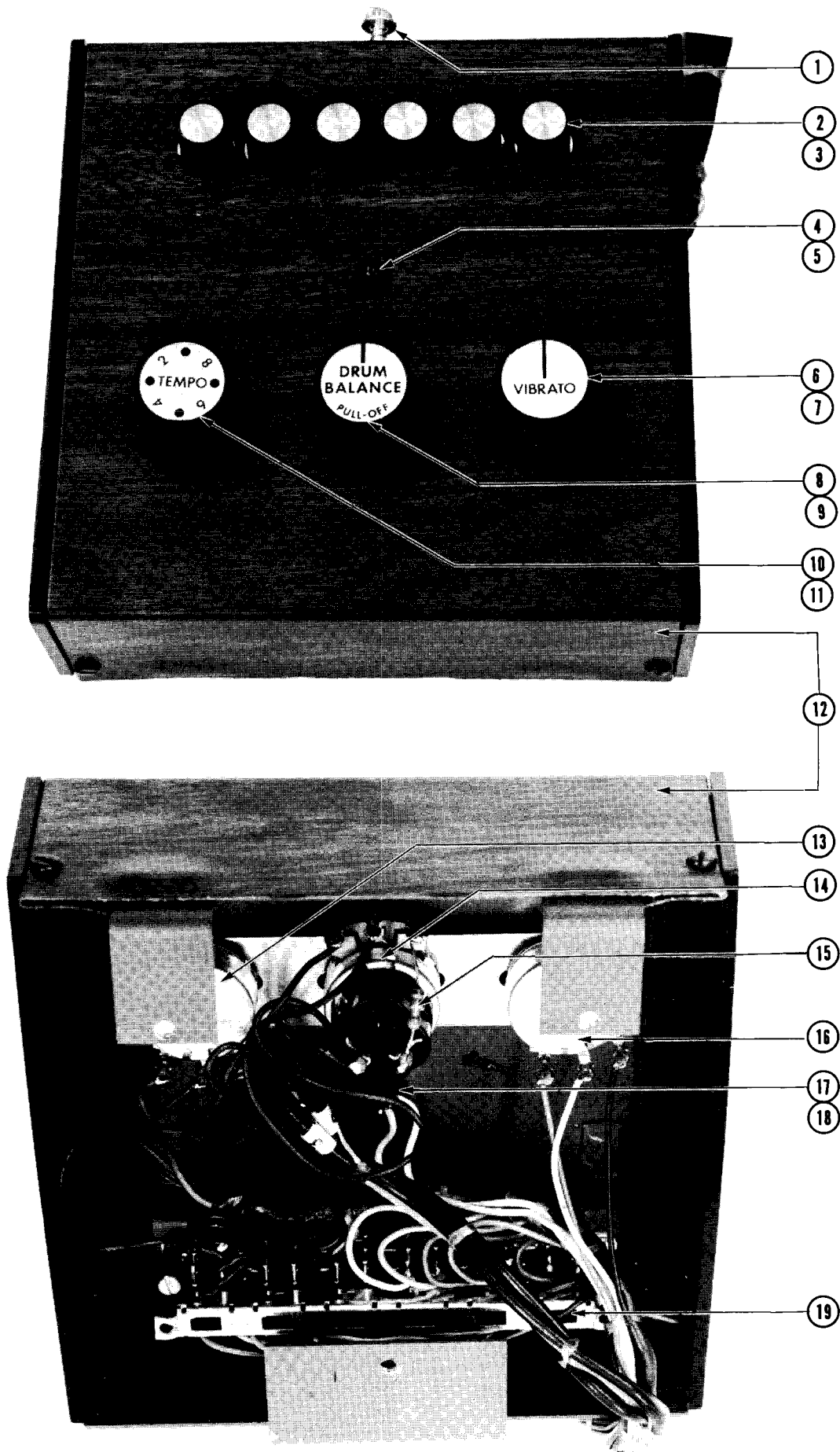

FIG. 9 — CENTER CONTROL KEYCAP ASSY.

DESCRIPTION - FIG. 9

ITEM	DESCRIPTION	PART NUMBER
1	SCREW SECURING CONTROL PANEL TO KEYCAP (SEE FIG. 4, ITEM 17)	
2	PUSH BUTTON	For Metal - A250-054568 For Acrylic - 0250-102115
3	PUSH BUTTON INSERT - BLUE	Metal - A247-054867 Acrylic - A247-103132
4	LIGHT EMITTING DIODE (L.E.D.)	X514-059254
5	L.E.D. MOUNTING CLIP	X514-059255
6	KNOB	A247-047794
7	KNOB ASSEMBLY, "VIBRATO"	A247-060067
	KNOB INSERT, "VIBRATO"	A249-060065
8	KNOB ASSEMBLY, "DRUM BALANCE, PULL OFF"	A247-060398
9	KNOB INSERT, "DRUM BALANCE, PULL OFF"	A249-060397
10	KNOB ASSEMBLY, "TEMPO"	A249-058982
11	KNOB INSERT, "TEMPO"	A249-058946
12	CENTER CONTROL KEYCAP	X500-060086
13	TEMPO POTENTIOMETER 100K LIN.	B509-040783
14	DRUM BALANCE POTENTIOMETER 100K LIN. W/SWITCH	B509-048340
15	180k, R4 RESISTOR (SEE KEYCAP WIRING DIA.)	
16	VIBRATO POTENTIOMETER 5k LIN.	B509-047956
17	L.E.D. FINAL ASSEMBLY	A514-058969
18	L.E.D. MOUNTING RING	X514-059256
19	PUSH BUTTON SWITCH ASSY. - 6 STATION	B506-060078
	KEY SELECTOR SWITCH ASSEMBLY W/PC BOARDS-121	0500-063750
	KEY SELECTOR SWITCH ASSEMBLY W/PC BOARDS-121W	0500-103315

1212

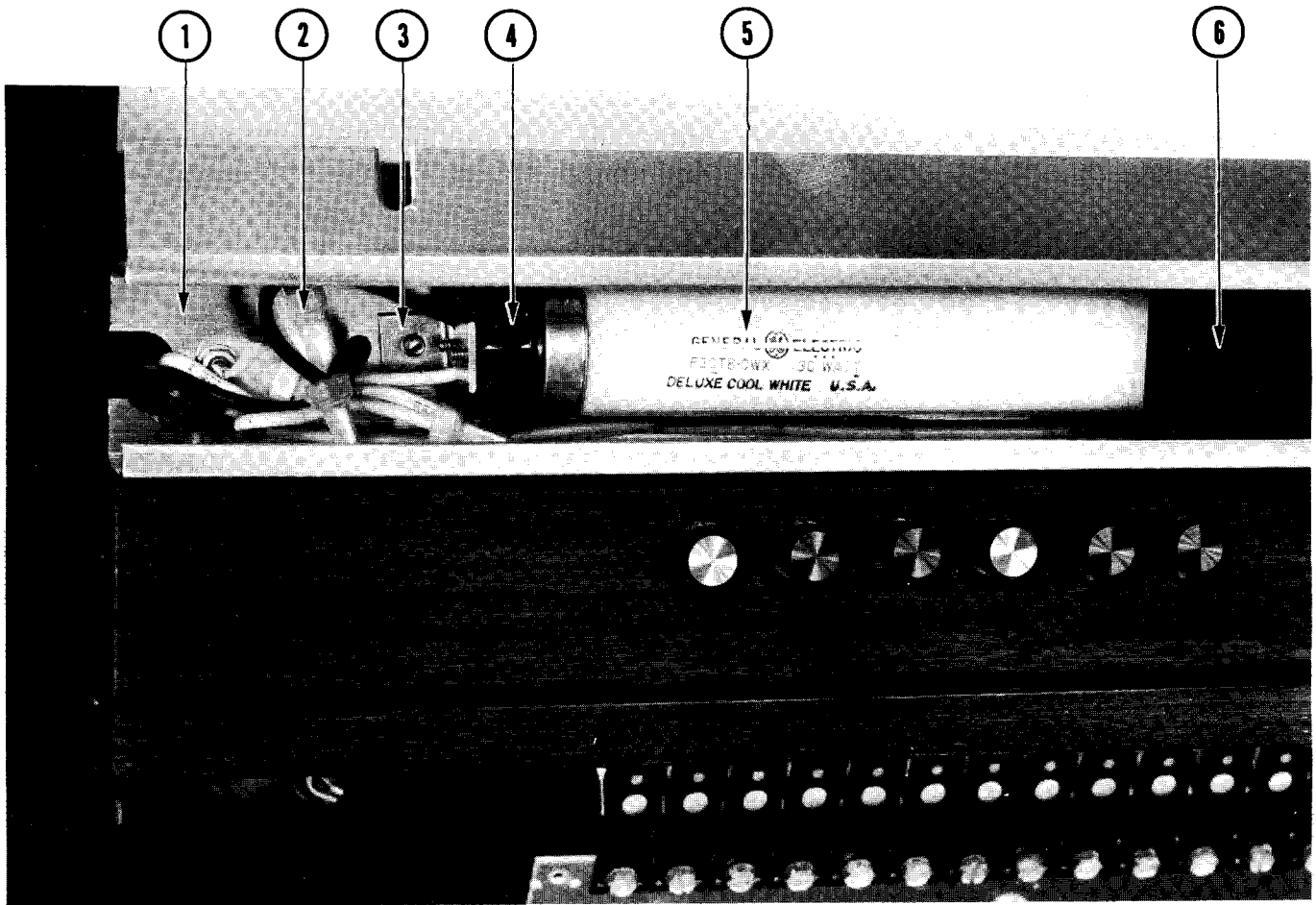
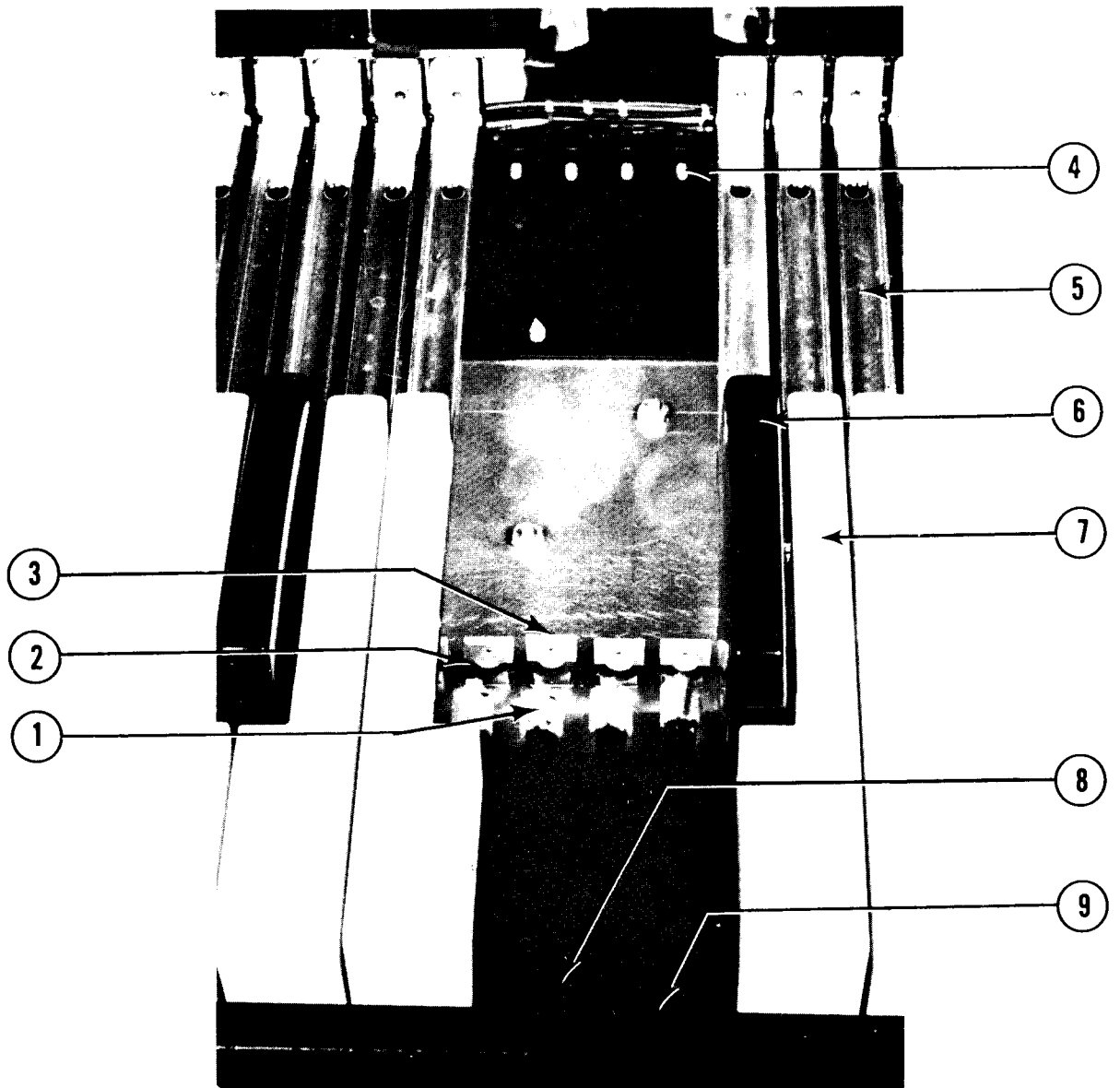

FIG. 10 - FLUORESCENT LIGHT MOUNTING

ITEM	DESCRIPTION	PART NUMBER
1	CONTROL PANEL ASSEMBLY	X500-060175
2	CLOSED END CONNECTOR	A507-035085
3	FLUORESCENT LAMP HOLDER BRACKET	A528-060523
4	FLUORESCENT LAMP SOCKET (BUTT ON)	A507-060525
5	FLUORESCENT LAMP - 30 WATT	A514-060528
6	LUMALITE STRIP (FUN MACHINE)	D249-060518



ITEM	DESCRIPTION	PART NUMBER
1.	FELT	
2.	NEOPRENE WASHER	A244-019857
3.	KEYSWITCH PLUNGER	SEE PARTS LIST
4.	KEYCHANNEL SCREW (LOOSEN TO REMOVE KEY)	A247-024602
5.	KEYCHANNEL	B250-024146
6.	SHARP KEY	C250-025895
7.	NATURAL KEY	SEE PARTS LIST
8.	KEYSTOP FELT	A244-022607
9.	KEYSLIP FELT	A244-024941

FIG. 11 KEYBED - 4 KEYS REMOVED

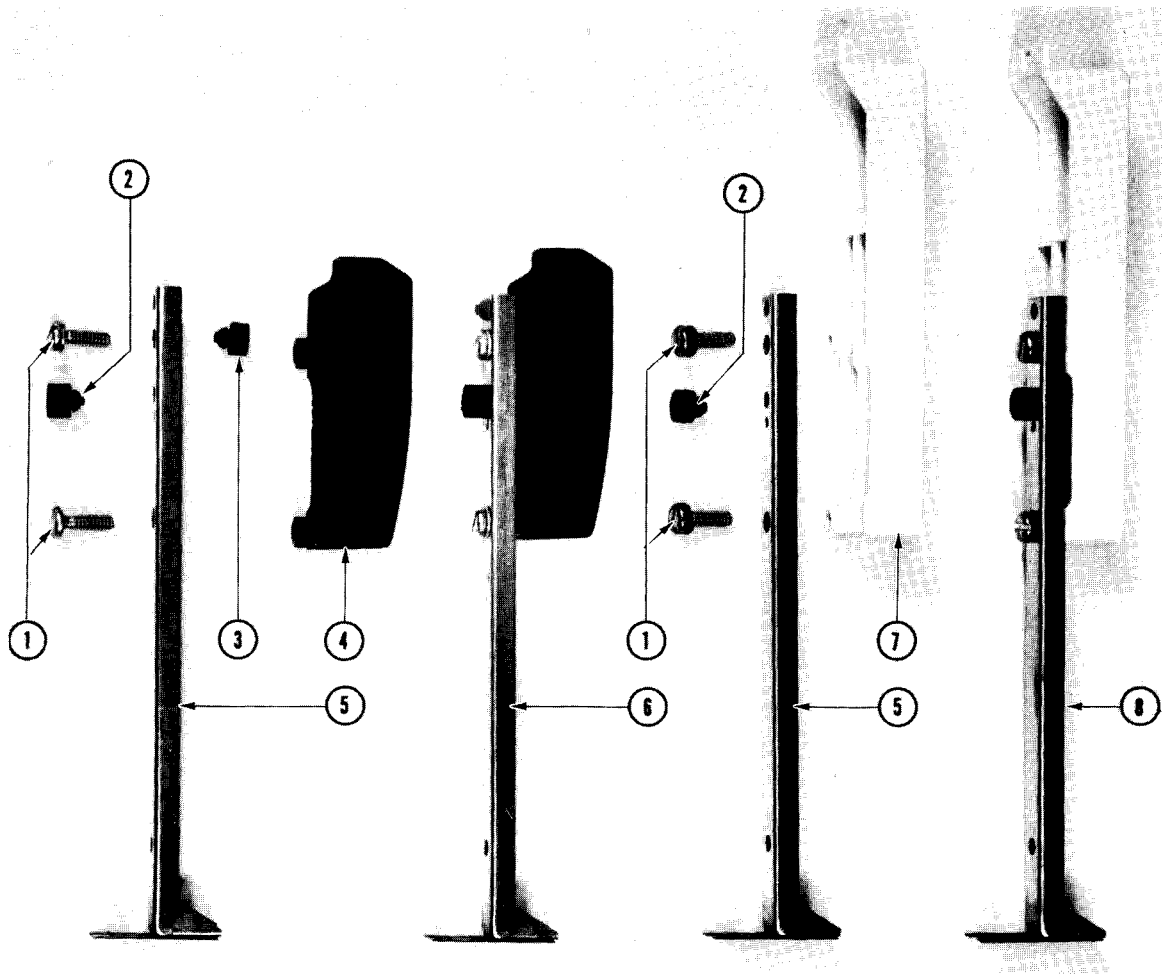

FIG.12 — KEY ASSEMBLIES

ITEM	DESCRIPTION	PART NUMBER
1	SCREW #10-24 B.H. MACH. 5/8 LG.	S2246-10-24-10 SCPL
2	KEYSWITCH BUMPER	A244-022488
3	KEY UPSTOP BUMPER (SEE NOTE)	A244-023942
	OR	A244-022488
4	PLASTIC KEY "SHARP"	C250-025895
5	KEY CHANNEL RIVETED	B250-054321
6	SHARP KEY ASSEMBLY	B250-054330
7	PLASTIC KEY NATURAL	SEE PARTS LIST
8	NATURAL KEY ASSEMBLY	SEE PARTS LIST

NOTE: KEY UPSTOP BUMPER SELECTED TO MEET TRAVEL AND HEIGHT DIMENSIONS.

BALDWIN MODEL 121 SERIES ORGAN

DISASSEMBLY PROCEDURE

1. Back (Fig. 3)
 - a. The back is secured by nine (9) screws. Remove the top four (4) screws and loosen the remaining five (5) screws across the bottom slots. Push upward and remove by pulling downward.
2. Keys and Keyswitches
 - a. Follow Step 1.
 - b. Keys may be removed by loosening mounting screw of a key channel. Sharp or black key must be removed first (Figs. 11 & 12).
 - c. Access to keyswitches may be obtained by removing keyswitch cover (Fig. 7). Remove six (6) screws from underneath the manual and loosen four (4) wood screws securing the keyswitch cover to lower frame.
 - d. Keyswitch assembly may be disassembled by removing nuts from switch posts.
3. Control Panel and Extrusion Assembly (Fig. 6)
 - a. To obtain access to the rear of Control Panel follow Step 1.
 - b. Loosen three (3) screws, securing the Control Panel to the rear of the keycaps (See Fig. 4, Item 17). Screws are fitted in slotted holes, therefore, the Control Panel, hinged at the sides, will now pivot upward from the normal position (Fig. 6).
4. Fluorescent Light and Starter (Control Panel) - Fig. 10
 - a. Follow Step 1.
 - b. Rotate starter counterclockwise and remove (Figs. 4 through 12).
 - c. To obtain access to fluorescent bulb, follow Steps 1 & 3b, slide Function nameplate out toward either side, and pry the bulb straight out to release bulb pins from socket (Fig. 10).
5. Control Panel Push Button Switch Assembly (Fig. 6)
 - a. Follow Steps 1 & 3b.
 - b. Unplug the push button edge connector.
 - c. Remove two (2) screws securing the push button switch assembly to the Control Panel.
6. Treble Keycap - Power Switch
 - a. Follow Steps 1, 2c & 3b.
 - b. Remove treble keycap by removing two (2) screws on the underside, which secure the keycap to the manual assembly (Fig. 7).
7. Bass Keycap
 - a. Follow Steps 1, 2c & 3b.
 - b. Remove bass keycap by removing two (2) screws on the underside, which secure the keycap to the manual assembly (Fig. 7).

Baldwin Model 121 Series Organ
Disassembly Procedure (Cont'd.)

8. Center Keycap (Fig. 9)

- a. Follow Steps 1, 2c & 3b.
- b. Remove center keycap by removing three (3) screws on the underside, which secure keycap to the manual assembly (Fig. 7).

9. Phone Jack Assembly

- a. To obtain access to Phone Jack Assembly, remove bass keycap as in Procedure Step 7.

10. Major/Minor Switch (Fig. 8)

- a. Access to Major/Minor switch may be obtained by removing six (6) screws securing the touch bar slip rail to manual (See Fig. 7).

11. Expression Pedal Assembly

- a. Follow Step 1.
- b. Remove the two (2) wood screws which secure the expression pedal assembly to the rear bottom board of the console.
- c. Pull the expression pedal assembly toward the rear of console in order to clear the screw from slotted hole and lift out.

12. Fun Machine Boards Assembly (Fig. 5)

- a. Follow Step 1.
- b. To remove Fun Machine Boards assembly from console, remove ten (10) wood screws securing the Rhythm Voice board to the console.

Disconnect the connectors and remove boards for servicing.

13. Fuse (Figs 4 & 14)

To obtain access to fuse, remove back as in Procedure Step 1. Fuseholder is located on the lower end of treble console side near the power transformer (See Fig. 14).

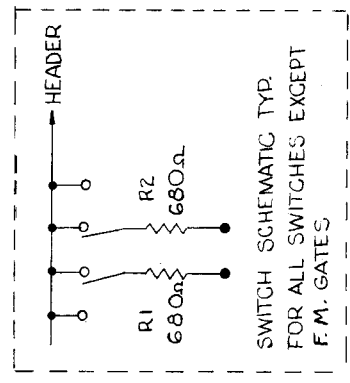
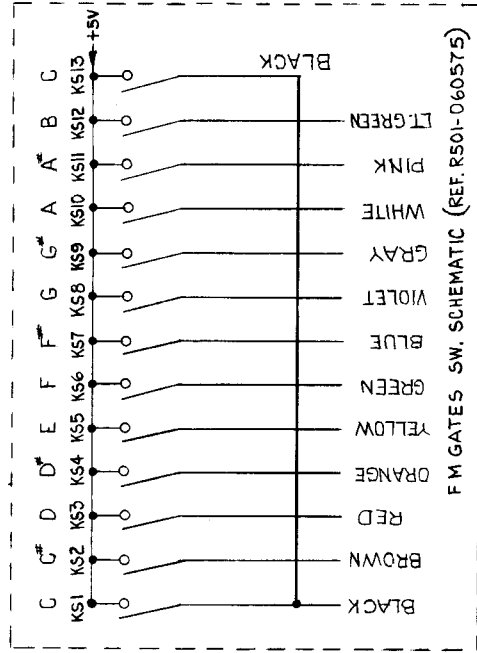
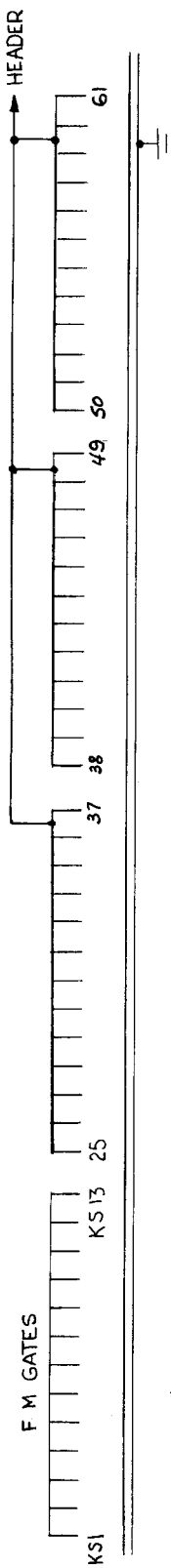

COLOR	NUMBER
BLACK	25 37 49 G1
BROWN	26 38 50
RED	27 39 51
ORANGE	28 40 52
YELLOW	29 41 53
GREEN	30 42 54
BLUE	31 43 55
VIOLET	32 44 56
GRAY	33 45 57
WHITE	34 46 58
PINK	35 47 59
LT. GREEN	36 48 G0
HEADER	YELLOW
GROUND	BLACK

*1#2

3	2	1
6	5	4
9	8	7
12	11	10

*3

3	2	1
6	5	4
9	8	7
12	11	10
15	14	13

NOTES:
 1. 39 CONNECTIONS - 25 THRU G1, GROUND AND HEADER TO GEN. BD. (DIODE GATE)

PIN#	WIRE#	PIN#	WIRE#
1	25	1	37
2	26	2	38
3	27	3	39
4	28	4	40
5	29	5	41
6	30	6	42
7	31	7	43
8	32	8	44
9	33	9	45
10	34	10	46
11	35	11	47
12	36	12	48
		13	G1
		14	YEL.
		15	BLK.

DATE 10-4-73 DWN. M. STEWARD CHD. 24. 24. APPD. 24. 24. E.P.T. X
 FINISH X DEC. X FAY. X
 USED ON MOD. 121
 PART NAME KEYSWITCH WIRING DIAGRAM
 GR. N.C.T.D. IT.
 SUPPERSEDES
 BALDWIN PIANO & ORGAN CO. CINCINNATI, OHIO
 B 501-060132

The tone generation system consists of a master oscillator circuit (clock) and an integrated SYNCHRONOUS FREQUENCY DIVIDER. The master oscillator frequency is applied to the frequency divider, via an oscillator buffer and driver circuit. The frequency divider provides 13 output frequencies, a full octave (C49 @ 523.25 Hz through B60 @ 987.77 Hz), plus one note (C61 @ 1046.5 Hz).

The master oscillator can be frequency modulated by the vibrato oscillator via the Current Source, thus the frequencies produced by the frequency divider will also be modulated.

The thirteen (13) frequencies produced by the frequency divider are applied to the corresponding diode gate circuits and to four (4) additional divide-by-two integrated frequency dividers (IC1 through IC4) via buffer amplifiers. Thus, the divide-by-two dividers provide an additional two full octaves (C25 @ 130.81 Hz through B48 @ 493.88 Hz).

This type of generation system produces a total of 37 frequencies. All 37 frequencies are applied to their corresponding diode gate circuits. One octave (12 notes) F[#]31 through F42, is applied to the Fun Machine (F.M.) Logic Board via twelve (12) buffer amplifiers.

MASTER OSCILLATOR (CLOCK)

The Master Oscillator (Clock) circuit, consisting of one NPN transistor (Q6) and associated circuits, is an L-C type oscillator. The frequency is adjustable and can be set by variable inductor LI. Due to the capability of using either of two different types of T.O.F.G. frequency dividers which require a different clock input frequency, the master oscillator frequency can be set to 250.113 kHz for MOSTEK, and 365.228 kHz for MOTOROLA IC dividers. The Master Oscillator tuning procedure is indicated on the T.O.F.G. Schematic D501-060684, which specifies that LI should be tuned (adjusted) to set the frequency of C61 to 1046.5 Hz.

Master oscillator output is buffered by Q7 and shaped by Q8 and Q9 into a waveform similar to a square-wave with a fast rise time, which is required to drive the frequency divider. Output of the master oscillator can be frequency modulated by means of a variable Current Source (Q5) and the Vibrato Oscillator voltage.

VIBRATO OSCILLATOR

The Vibrato Oscillator, located on the T.O.F.G. board assembly, consists of Q3 and associated circuitry, and produces a 6.4 Hz output signal. Resistor RS12 is factory selected to set the vibrato oscillator frequency. The vibrato oscillator voltage, applied to the master oscillator via R13, R3 potentiometer, and C7 to current source Q5, shifts the oscillator frequency at the 6.4 Hz rate. The vibrato potentiometer controls the master oscillator frequency deviation. At full vibrato the total frequency deviation is 2.5%.

A delayed vibrato effect, controlled by the right hand, is incorporated and consists of Q1 and Q2 circuit located on the T.O.F.G. board, and Q109 and Q112 circuit located on the Right Hand board assembly.

When no keys are played, transistor Q112 is unsaturated permitting the +27 volts to be applied to the base of Q1 via R576, D133 and R2. Both transistors, Q1 and Q2, will saturate and hold the vibrato oscillator off. When any key in the right hand range is played, Q109 saturates, providing two bits of information for the vibrato oscillator circuit.

Q112 goes out of saturation, removing, via D133, the saturation bias for Q1, normally supplied when a key is not played. At the same time, Q109 provides a trigger via D129, C1, and R2 to the base of Q1, which will remain saturated for a given period of time, holding the vibrato oscillator off. After that period of time, Q1 and Q2 will unsaturate, permitting the vibrato oscillator to operate.

When a key played is released, Q112 will remain saturated until C470 discharges through D132, R599, and Q87. This action permits the vibrato oscillator to operate until played signals have sustained away.

T.O.F.G FREQUENCY DIVIDER

The MOSTEK (MK 5024) is an ION-IMPLANTED, P-CHANNEL MOS, SYNCHRONOUS FREQUENCY DIVIDER, with thirteen (13) output frequencies forming a full octave plus one note of the equal tempered scale. This divider is packaged in a 16 pin CDIP (Ceramic Dual in Line Package), and requires only a single power supply source (+14 VDC). The Clock input frequency required for the MOSTEK divider is 250.113 kHz with a rise time of, at most, 30 ns.

T.O.F.G. Frequency Divider (Cont'd.)

The MOTOROLA (MC 6520) is a NMOS TOP OCTAVE SYNTHESIZER also providing thirteen (13) output frequencies. This Motorola divider is packaged in a 22 pin IC and requires +5V and -3V supply source. The -3V supply source is derived from -9V supply via resistive dividers R355, R36, and R37, and base emitter forward drop of Q11 transistor.

The Clock Input Frequency requirement for MOTOROLA divider is 365.228 kHz.

Output frequencies from the divider are buffered by buffer amplifiers Q12 through Q24 before application to the gate and divider circuits.

GATE AND DIVIDER CIRCUIT

For reference of note generation and distribution, refer to Drawing C579-412.

Twelve (12) frequencies, C49 through B60 from the T.O.F.G. buffer amplifiers are divided by four (4) divide-by-two IC dividers, thus establishing an additional two octaves of frequency.

A total of 37 signals are applied to the Diode Gate "Signal In" inputs and later are used for Right Hand voicing. This diode gate system employs a pair of diodes (typically D2 and D3 - Refer to Schematic C501-060143), a timing capacitor (C4), and a short sustain network (R37 and D1) for each of 37 signals. Capacitor C changes the squarewave input to a sawtooth waveform and aids in reducing any "bleed-through".

With no gate voltage applied, D2 is biased off with respect to the incoming signal, causing it to appear as a high resistance. Application of a gate voltage from the keyswitch common buss by closing the keyswitch, applies a positive voltage to the anodes of D2 and D3, forward biasing them and allowing the "Signal In" to be conducted to the output header. At the same time, capacitor C4 (2.2 mfd) is charged by the gating voltage.

When a key is released (keyswitch open), the forward bias on the diodes will decrease as capacitor C4 discharges through R38, R39 and filter components following. As this forward bias decreases, the diode resistance increases with respect to the incoming signal, until the signal reduces to inaudibility and the circuit returns to its original unkeyed state.

Diode D3 is used to isolate the gate from other gates, preventing the gate from being operated by other gates connected in common.

Short sustain is accomplished by returning the resistor-diode network (R37-D1) to ground through short sustain buss in the right hand circuit, thus, shortening the sustain time by providing an additional discharge path.

Outputs of the gate circuits are collected in five (5) headers (groups) of 6 diode pairs each and one header consisting of 7 diode pairs. Outputs from the headers are fed into a three-section ladder filter on the right hand voice board assembly.

One octave, F#31 through F42, from the divide-by-two IC dividers is buffered by the buffer amplifiers Q1 through Q12 and is used as the Fun Machine (Left Hand) signal source.

RELEASED
 Ord. No. / /
 Date / /
 RECORD OF CHANGE

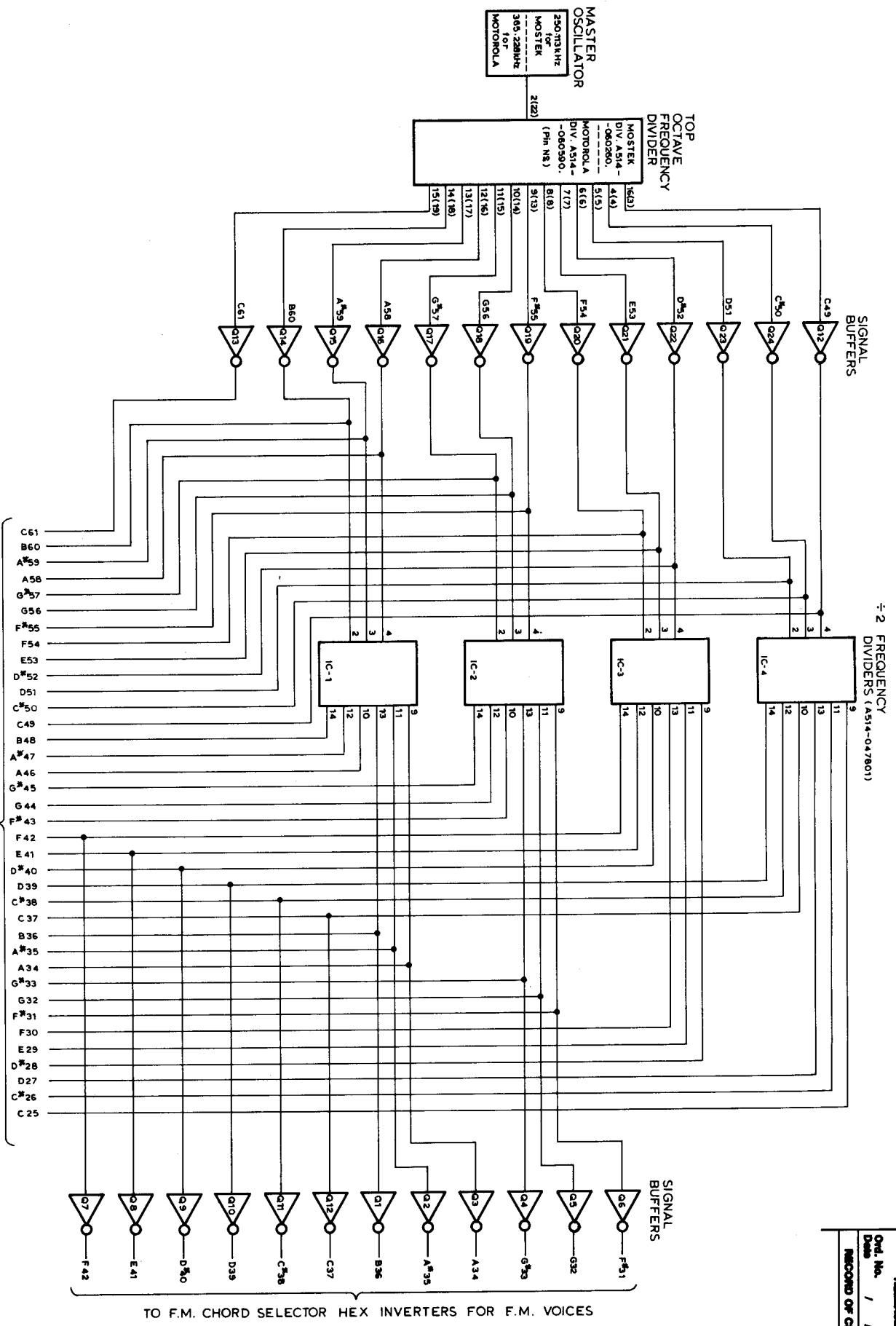

TO DIODE GATES FOR RIGHT HAND VOICES

TO F.M. CHORD SELECTOR HEX INVERTERS FOR F.M. VOICES

COMPONENTS LOCATED ON
 T.O.F.G. BOARD ASSY.
 SCH. NO. D501-060884

COMPONENTS LOCATED ON
 GATE & DIVIDER BD. ASSY.
 SCH. NO. C501-080143

DATE: 2-24-74		DWN: V.L.O.		CMT:		APPRD:		ISSUANCE: USED ON 121	
DESIGNER	CNK	GR	CON	F.V.	DEQ	E.P.T.			
PARTNAME: FUN MACHINE FREQ. GENERATION & DISTRIBUTION					FINISH: BLM				
DISTRIBUTION: BALDWIN PIANO & ORGAN CO. CINCINNATI, OHIO					SUBPAGES: C 579-412				

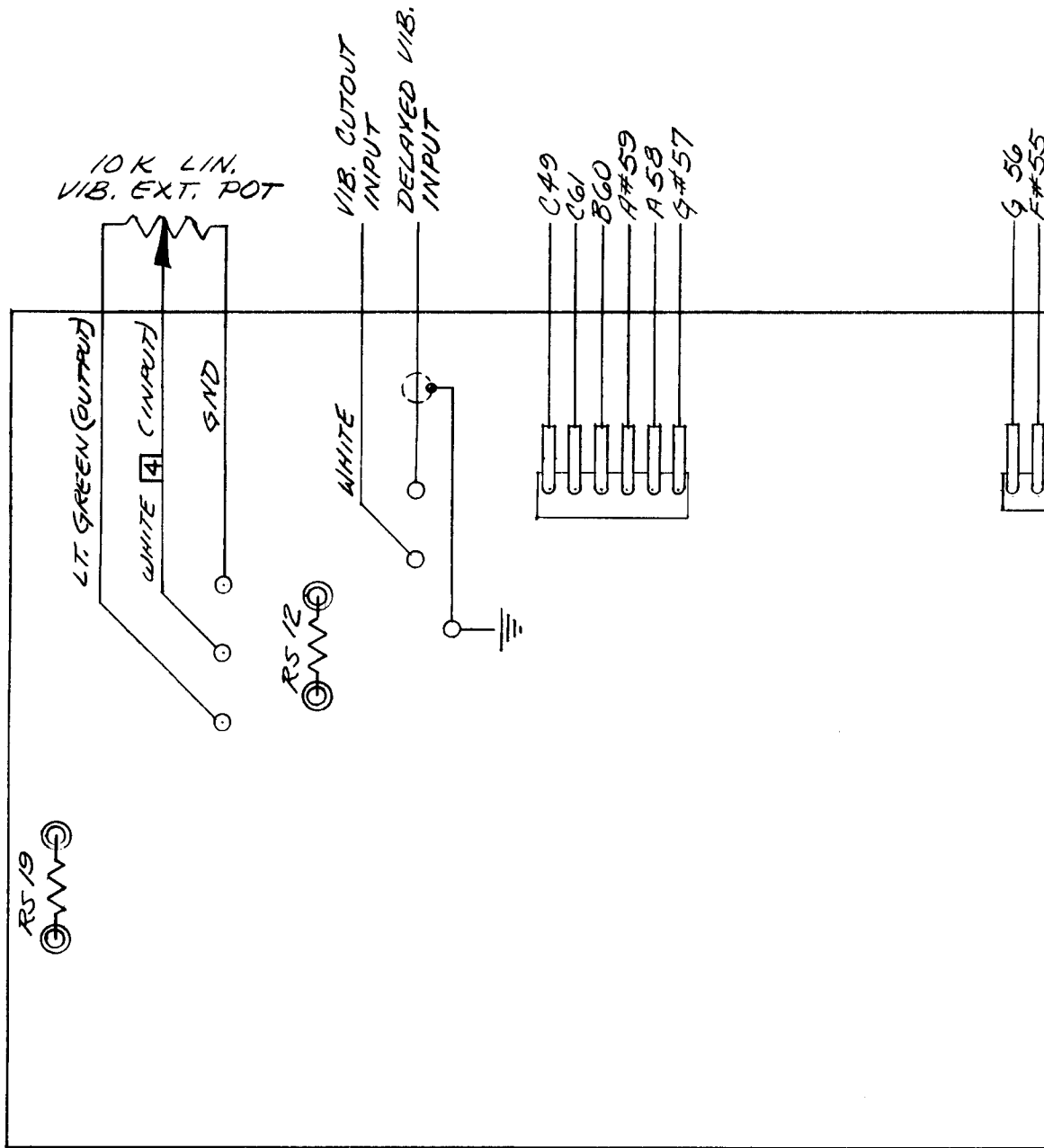

DATE 9-3-73		DWN. BRADY
PRINT	CIN.	GR.
DISTRIBUTION	S	
ALL DRAWINGS AND SPECIFICATIONS ARE AN RETURNED TO IT. ALL SPECIFICATIONS ARE CON TO WHOM THEY ARE SENT. NO DRAWINGS, SPE WHICH MAY BE FURNISHED TO MANUFACTURE OTHERWISE AS IN ANY MANNER LICENSING THE OR PERMISSION TO MANUFACTURE, USE OR S		
UNLESS OTHERWISE SPECIFIED TOL		

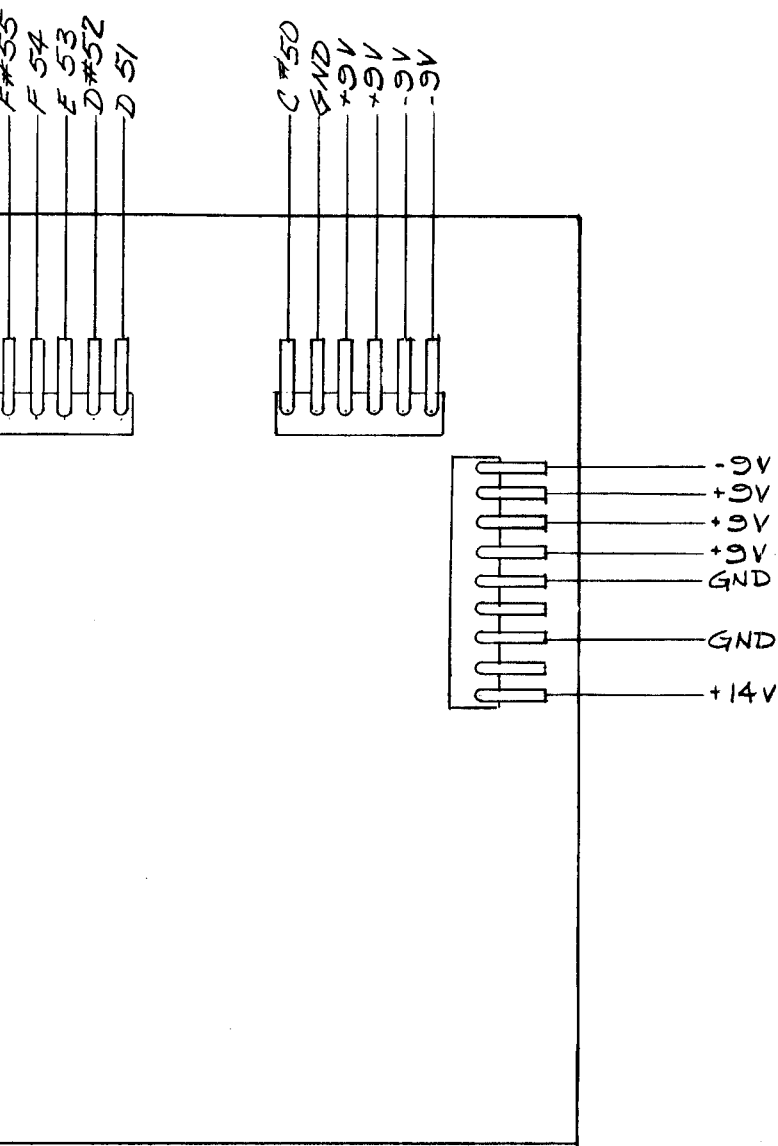

RELEASED

Ord. No. *R.N. 650*
Date *11/18/74*

RECORD OF CHANGE

- ⓑ REDRAW, NO CHANGE
9-3-73 KMB
- ⓒ REVISED TO DELETE
MOTOROLA T.O.G.F. DEVICE
3-13-75 - D.R.B. C.N. 16,213

04	CH'D <i>9-3-74</i>	APP'D. <i>Rob.</i>	DWN. SCALE FULL	USED ON ORGAN 121 127	PART NAME T.O.F.G. B'D. - PIN WIRING DIA.	
CON.	FAY. X	DEQ. X	E. P. T.	REQ. —	B/M 503-121-5 GR. NOTED IT. 503-127-5	
<small>AND REMAIN THE PROPERTY OF THE BALDWIN PIANO & ORGAN CO. AND MUST BE CONFIDENTIAL AND ARE NOT TO BE DISCLOSED TO ANY PERSONS OTHER THAN THOSE SPECIFICATIONS OR OTHER DATA BELONGING TO THE BALDWIN PIANO & ORGAN CO. PURCHASERS OR OTHERS FOR ANY PURPOSE ARE TO BE REGARDED BY IMPLICATION OR THE HOLDER OR ANY OTHER PERSON OR CORPORATION OR CONVEYING ANY RIGHTS OR SELL ANY PATENTED INVENTION THAT MAY IN ANY WAY BE RELATED THERETO.</small>				FINISH	NEXT ASSEM.	
<small>TOLERANCES ARE: DECIMAL ± .005 FRACTIONAL ± .015 ANGLE ± 1/2°</small>				BALDWIN PIANO & ORGAN CO. CINCINNATI, OHIO		SUPERSEDES B 501-060641 C
						REV.

RELEASED

Ord. No. RN 650
Date 1/31/74

RECORD OF CHANGE

- A) DELETED R15-10K RESISTOR
CN 15,760 M.S. 2-26-74
- B) ADDED R79. C14 WAS .01 μ F
R18 WAS 15K.
CN 15,792 D.L.L. 3-19-74
- C) R5 WAS 220K.
CN 15,959 K.E.J. 7-16-74
- D) REDRAWN PER T.S. REQUEST
9-9-74 D.DIEHL
1250
DELETED: R30-R31-R32-
R33-R34-R16 & R17;
C1 & C23;
D2 & D3;
Q4 & Q10;
SHARPING & FLATTING
CKTS. PER
CN 16087 H.C.R. 10-1-74
- E) REVISED TO DELETE
MOTOROLA IQ OF DEVICE
3-13-75 - DRB CN 16,213

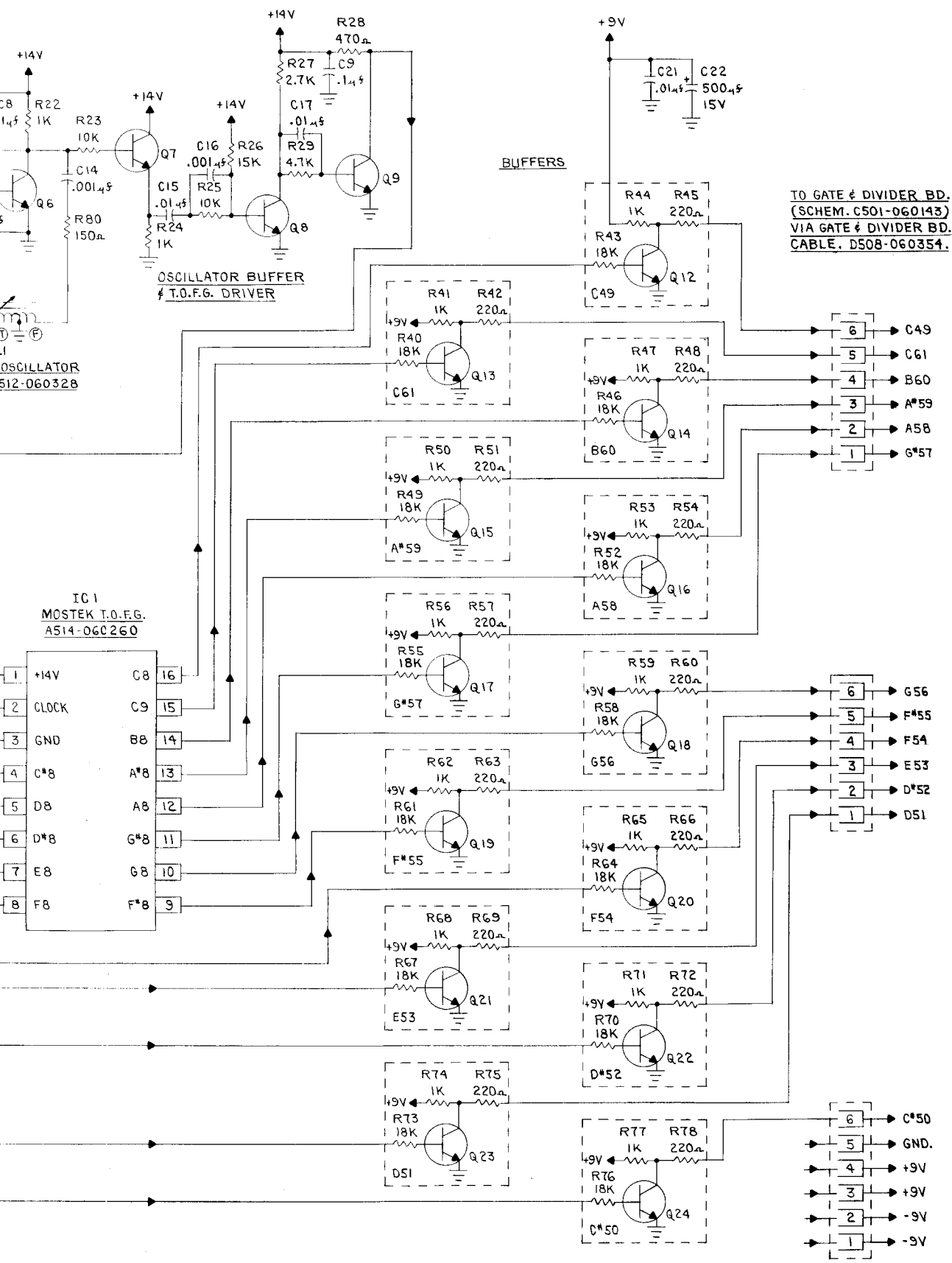

TO GATE & DIVIDER BD.
(SCHEM. CS01-060143)
VIA GATE & DIVIDER BD.
CABLE, DS08-060354.

IC1
MOSTEK I.O.F.G.
A514-060260

DATE 9-9-74	OWN. D.DIEHL	CHD.	APPD. <i>Rev</i>	OWN.SCALE	USER ON ORG. CN 121,127	PART NAME
						T.O.F.G. BOARD - SCHEMATIC
LAST USED	PRINT	CINL	GR.	CONL	FAY.	DEQ.
R80	S					E.P.T.
C23						
Q24						
D3						
L1						
ALL DRAWINGS AND SPECIFICATIONS ARE AND REMAIN THE PROPERTY OF THE BALDWIN PIANO & ORGAN CO. AND MUST BE RETURNED TO IT. ALL SPECIFICATIONS ARE CONFIDENTIAL AND ARE NOT TO BE DISCLOSED TO ANY PERSON OTHER THAN THOSE TO WHOM THEY ARE FIRST AND SOLELY INTENDED. SPECIFICATIONS OR OTHER DATA RELAYED TO THE BALDWIN PIANO & ORGAN CO. WHICH MAY BE REPRODUCED TO MANUFACTURE OR OTHERWISE FOR ANY PURPOSE OR FOR ANY OTHER PERSON OR ENTITY WITHOUT THE WRITTEN PERMISSION OF BALDWIN PIANO & ORGAN CO. OR PERMISSION TO MANUFACTURE, USE OR SELL ANY PATENTED INVENTION THAT MAY IN ANY WAY BE RELATED THERETO.						FINISH
						BALDWIN PIANO & ORGAN CO. CINCINNATI, OHIO
						BM 505-181-5 205-127-5
						OR NOTED
						SUPERSEDES
						D 501-060684 E
UNLESS OTHERWISE SPECIFIED TOLERANCES ARE: DECIMAL 2.00% FRACTIONAL 2.0% ANGLE 2.0°						

VIBRATO OSCILLATOR

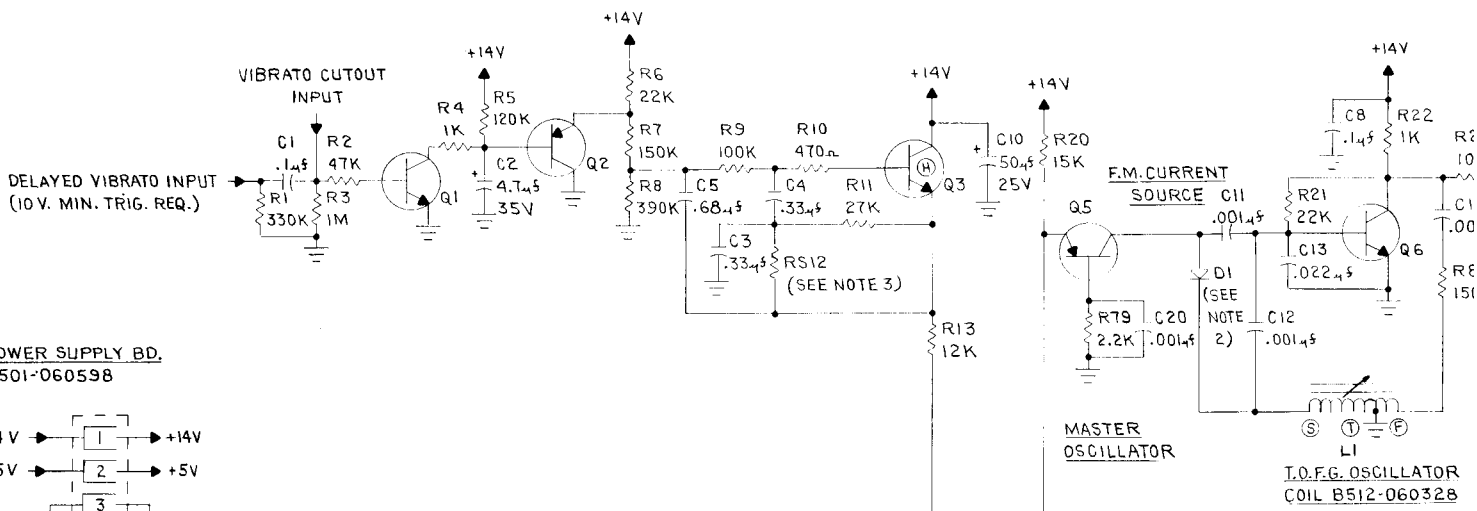

FROM POWER SUPPLY BD.
REF. C501-060598

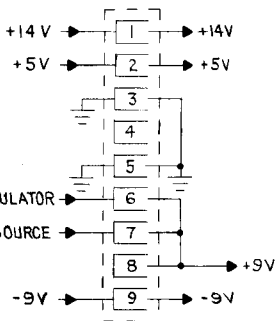

NOTES:

1. SELECT NPN TRANSISTORS PER S429 - AS INDICATED.
2. D1 IS A 100V DIODE (A514-033903).
3. SELECT RS12 FOR A 6.4Hz VIBRATO FREQUENCY. SELECTION RANGE 27K TO 820K.
4. SELECT RS19 FOR VIBRATO EXTENT OF 3% WITH R3 VIBRATO POT. AT MAXIMUM. SELECTION RANGE 1.2K TO 150K.
5. TUNE L1 TO SET FREQUENCY OF C' 61 TO 1046.5 Hz.

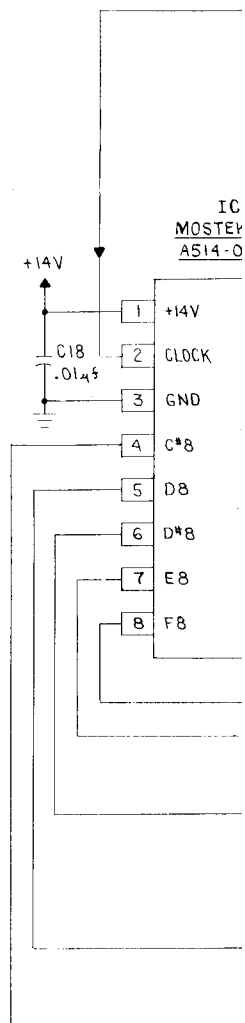
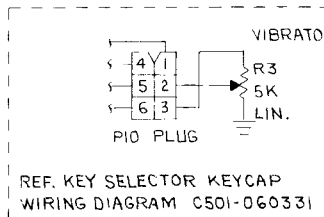
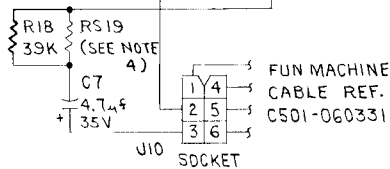

NOTES:

- 1.
2. REFERENCE SCHEMATIC - D501-060684
3. PIN WIRING DIAGRAM - 8501-060641
4. SELECT RS12 FOR A 64 HZ VIB. FREQUENCY SELECTION RANGE 27K TO 820K.
5. SELECT RS13 FOR VIB. EXTENT OF 3% WITH R13 AT MAX. VIBRATO SELECTION RANGE 1.2K TO 150K.
7. TUNE TO 1046.5 HZ @ "C" 61.
8. SELECT Q3 PER 5420-AS INDICATED.
9. FINAL ASSEM. MUST INCLUDE PART NUMBER 500-060640H.
10. Q8 & Q9 DO NOT USE G.E. TRANSISTORS.

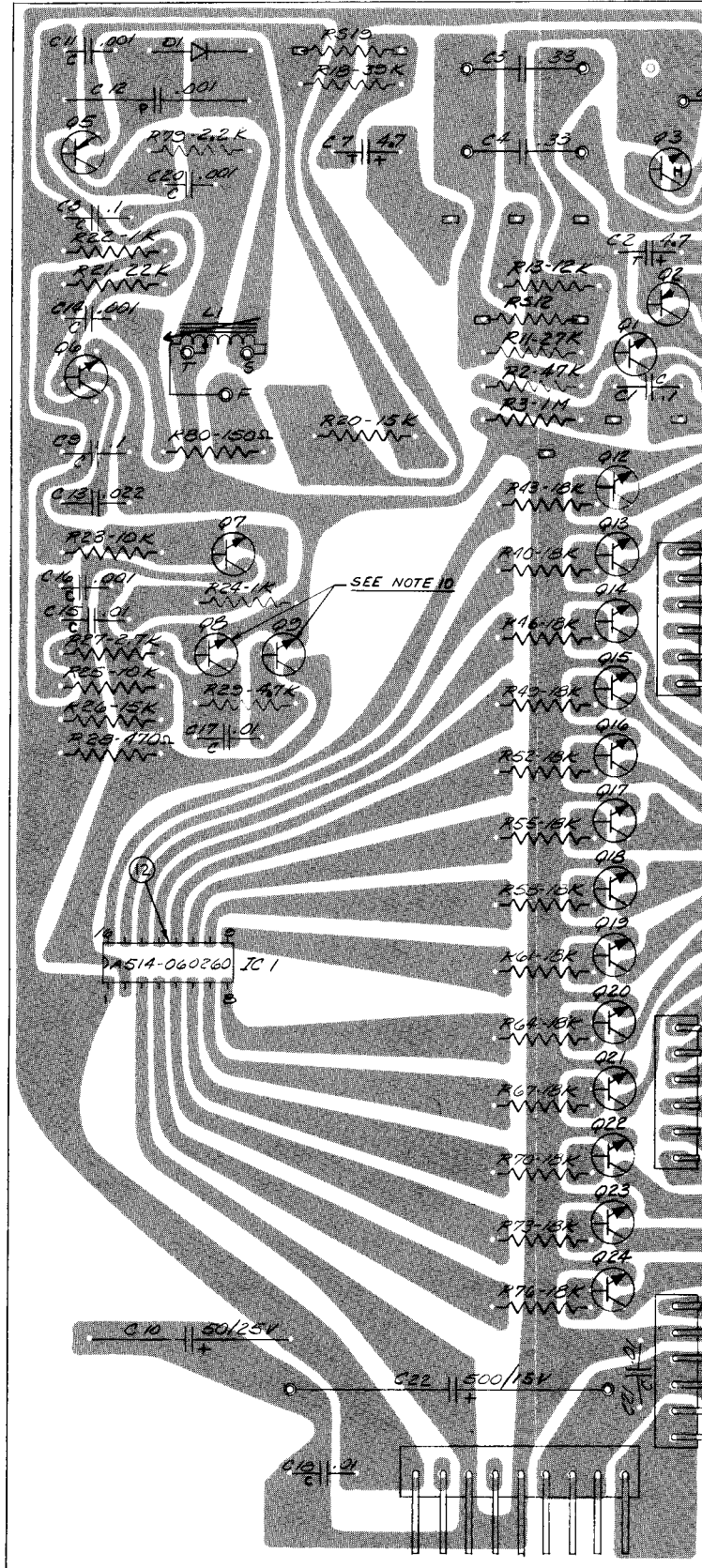

RELEASED
 Ord. No. R.N.650
 Date 11/18/74

RECORD OF CHANGE

④ REDRAWN 2x SIZE 9-3-74 K.M. SPADY
 ALSO DELETED COMPONENT NECESSARY FOR GLID. FEATURE PER C.M.16087 H.C.R. 10-9-74

⑤ DELETED ITEMS 8, 12, 13
 IT. 8 WAS A507-059132
 IT. 12 WAS A507-060591
 IT. 13 WAS A507-060150
 ADDED NEW IT. 12.
 C.M.16163 1-22-75 DP

⑥ REVISED TO DELETE MOTOROLA TO.F.G. DEVICE 3-13-75 D.R.B. C.N.16.212

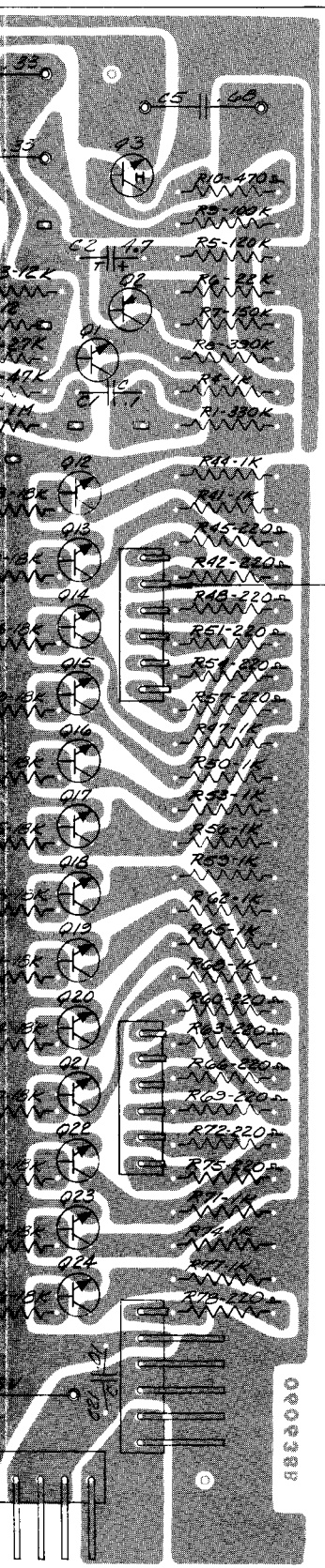

SEE NOTE 7 (C'61)

LEGEND:
 "C" DENOTES CERAMIC CAPACITOR
 "T" DENOTES TANTALUM CAPACITOR
 "P" DENOTES POLYMYLAR CAPACITOR
 CAPACITORS UNMARKED ARE MYLAR
 CAPACITORS MARKED WITH A POLARITY SIGN ARE ELECTROLYTIC.

53					
52					
51	1	5233-393-10	RESISTOR 30K 1/2W 10%		
50	1	5233-151-10	RESISTOR 150Ω 1/2W 10%		
49	1	5233-105-10	RESISTOR 1M 1/2W 10%		
48	X	5134-4	SOLDER IRON		
47	X	5134-3	SOLDER DIP		
46					
45	2	S244-20-475-2	CAP. 4.7HF TANTALUM		
44	1	S211-015-500	500HF 15V ELECT.		
43	1	S211-025-050	50HF 25V ELECT.		
42					
41	3	S218-104	.1 CERAMIC		
40	4	S205-103	.01 CERAMIC		
39	4	S205-102	.001 CERAMIC		
38	1	S232-01-684	.68 MYLAR		
37	2	S232-01-334	.33 MYLAR		
36	1	S232-01-223	.022 MYLAR		
35	1	S411-01-102	CAP. .001 POLYMYLAR		
34	2	S233-XXX-10	RESISTOR SEL. 1/2W 10%		
33	1	394	390K		
32	1	394	330K		
31	1	124	120K		
30	1	154	150K		
29	1	104	100K		
28					
27	1	473	47K		
26	1	273	27K		
25	2	223	22K		
24	13	183	18K		
23	2	153	15K		
22	1	123	12K		
21	2	103	10K		
20					
19	1	472	4.7K		
18	1	272	2.7K		
17	1	222	2.2K		
16	16	102	1K		
15	2	471	470Ω		
14	13	S233-221-10	RESISTOR 220Ω 1/2W 10%		
13					
12	1	514-061891	DIP SOCKET-16 CONN. SEE DIM. DWG. A514-061889		
11	3	A507-059125	WAFER INTERCONN. 6 PIN		
10	1	A507-059127	WAFER INTERCONN.-9 PIN		
9	1	B512-060328	T.O.F.G. COIL ASS'Y		
8					
7					
6	1	A514-060260	MOSTEK (T.O.F.G.)		
5	1	A514-033303	DIODE HIGH VOLTAGE		
4					
3	2	A514-044210	TRANSISTOR-PNP		
2	19	1161A-033338	TRANSISTOR-NPN		
1	1	B505-060630	T.O.F.G. 8'D RIVETED		

DATE 8-30-74	DWN. ERANDY	APP'D. [Signature]	DWN. SCALE 2x SIZE	USED ON 122-121	PART NAME TOP OCTAVE FREQUENCY GENERATOR B'D ASSEMBLY
PRINT FILE	GR. CONL.	FAY. DEO. E.P.T.	REG. 1	FINISH	B.M. 505-121-5 505-127-5 GR. 2 IT.
ALL DRAWINGS AND SPECIFICATIONS ARE AND REMAIN THE PROPERTY OF THE BALDWIN PIANO & ORGAN CO. AND MUST BE RETURNED TO IT. ALL SPECIFICATIONS ARE CONFIDENTIAL AND ARE NOT TO BE DISCLOSED TO ANY PERSON OTHER THAN THOSE TO WHOM THEY ARE SENT. NO DRAWINGS, SPECIFICATIONS OR OTHER DATA BELONGING TO THE BALDWIN PIANO & ORGAN CO. WHICH MAY BE REPRODUCED OR USED FOR ANY PURPOSE ARE TO BE REPRODUCED BY IMPLICATION OR OTHERWISE IN ANY MANNER, LOANING THE HOLDER OR ANY OTHER PERSON, OR COPIATION OR CONVEYING ANY RIGHTS OR PERMISSION TO MANUFACTURE, USE OR SELL ANY PATENTED INVENTION THAT MAY IN ANY WAY BE RELATED THEREBY.			NEXT ASSEM. 2003-060481		SUPERSEDES
UNLESS OTHERWISE SPECIFIED TOLERANCES ARE: DECIMAL 2.005 FRACTIONAL 2.015 ANGLE 2.1°			BALDWIN PIANO & ORGAN CO. CINCINNATI, OHIO		D 500-060640

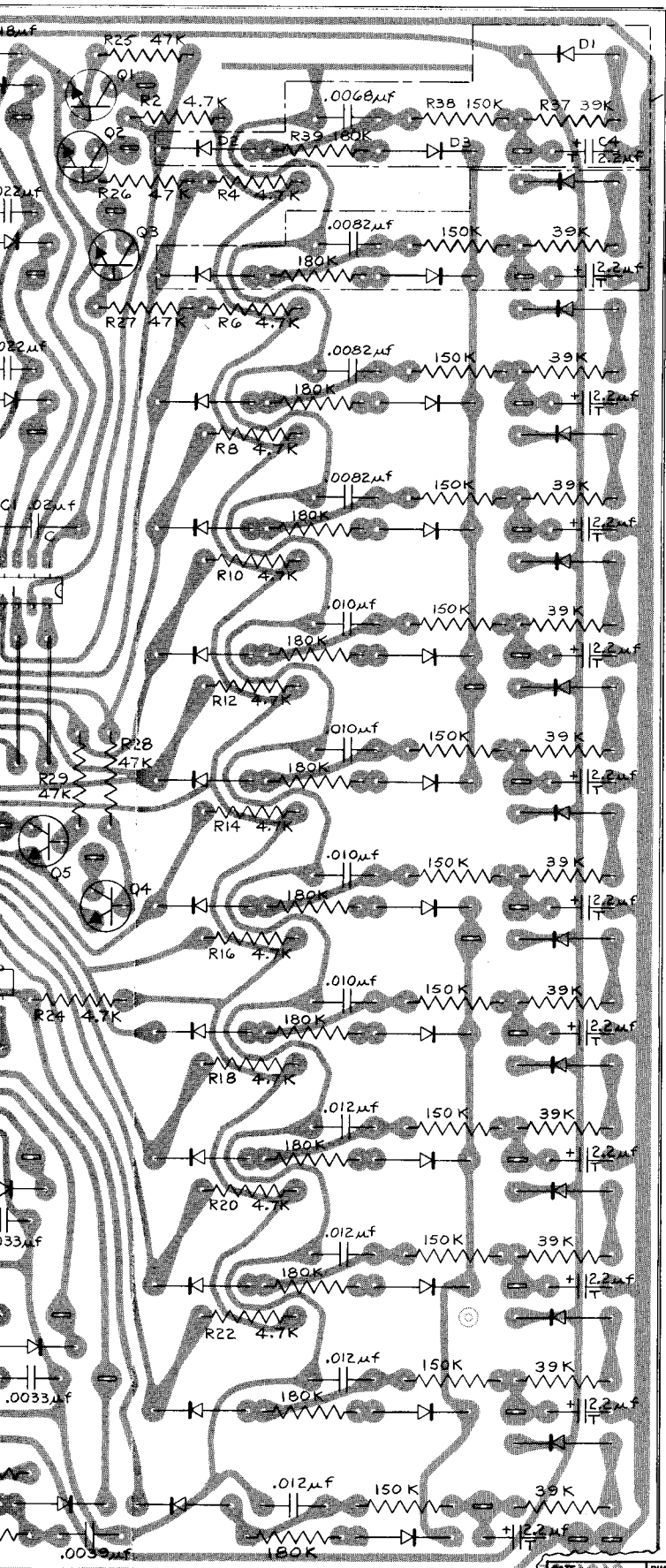

TYPICAL CIRCUIT FOR 37 GATES.

LEGEND:
 C - DENOTES CERAMIC CAPACITOR
 T - DENOTES TANTALUM CAPACITOR

NOTES:
 1. REFERENCE SCHEMATIC - C501-060143.
 2. PIN WIRING DIAGRAM - C501-060131.
 3. FINAL ASSY. MUST INCLUDE LABEL
 MARKED 500-060130 F

RELEASED
 Ord. No. R.N. 650
 Date 1/18/74

RECORD OF CHANGE

C) COMPONENT RELOCATION PER C.N. 15785.
 D) LANHAM 3-22-74
 D) REDRAWN, CHANGED FROM C-2 TO D-2 & FROM FULL SIZE TO 2 X SIZE NO C.N. H.C.P. 9-16-74
 E) PART NO. OF IT.4 WAS -047801 ADDED IT.28 CH 16,419 - 9-9-75
 F) ALL RESISTORS WIRE 5291 - 1/2 W 10%
 CN 16,532 1-30-76 R.M.

28	4	514-061890	DIP SOCKET-14CDNN. (REF.A514-061889)
27	1	C508-060686	GATE OUTPUT CABLE (NOT SHOWN)
26	X	S134-4	SOLDER - IRON
25	X	S184-3	SOLDER - DIP
24	X	S137-4	WIRE #22 BARE COPPER
23	4	S232-01-123	CAPACITOR .012μf MYLAR
22	4	↑	↑ 103
21	3	↑	↑ 822
20	4	↑	↑ 682
19	3	↑	↑ 562
18	4	↑	↑ 472
17	3	↑	↑ 392
16	3	↑	↑ 332
15	4	↑	↑ 272
14	3	↑	↑ 222
13	2	S232-01-182	.0018μf MYLAR
12			
11	4	S205-203	.02μf CERAMIC (C)
10	37	S244-25-225-1	CAPACITOR 2.2μf TANTALUM (T)
9	37	S250-184	RESISTOR 180K 1/4 W 5%
8	37	↑	↑ 154
7	12	↑	↑ 473
6	37	↑	↑ 393
5	24	S250-472	RESISTOR 4.7K 1/4 W 5%
4	4	A514-06135	FREQUENCY DIVIDER
3	111	A514-042791	DIODE - MED. VOLTAGE
2	12	A514-033338	TRANSISTOR NPN
1	1	C505-060129	GATE & DIVIDER B'D. RIV.

ITEM	READ	PART NO.	PART NAME
DATE	4/74	DWN: ROBERTE	CHD.
APPD.	Robt.	DEC.	E.P.T.
SCALE	2 X	USED ON	MOD. 121
PART NAME		GATE AND DIVIDER B'D. ASSEMBLY	
FINISH	BM503-121-5	GR.	1
NEXT ASSEM.		D603-060481 SUPERSEDES C500-060130C	
BALDWIN PIANO & ORGAN CO. CINCINNATI, OHIO		D	500-060130 F

UNLESS OTHERWISE SPECIFIED TOLERANCES ARE: DECIMAL ±.008 FRACTIONAL ±.015 ANGLE ±.1°

10.0 REF.

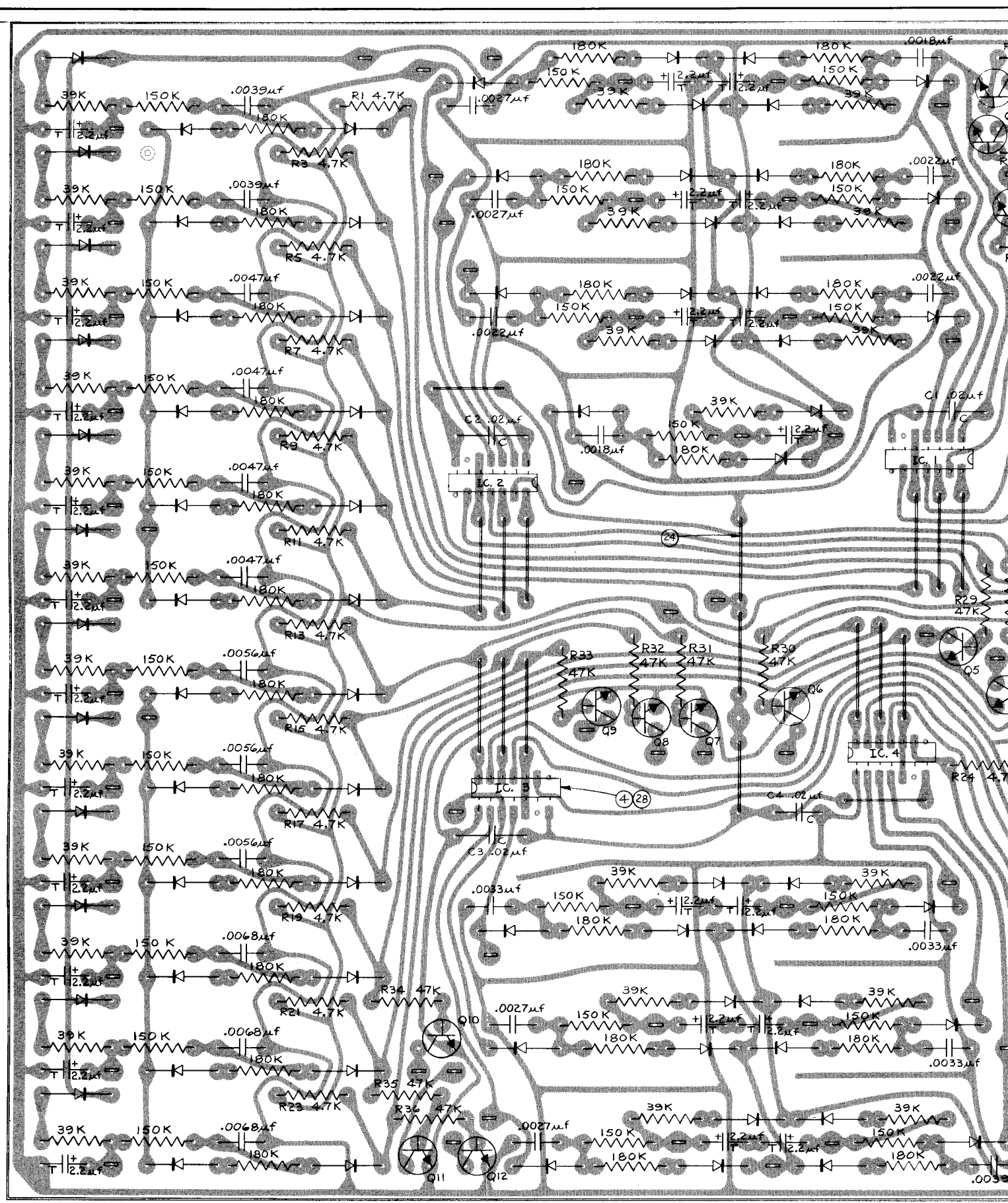

12.0 REF.

FROM TOP OCTAVE
FREQUENCY GEN. BD. REF. D501-060684

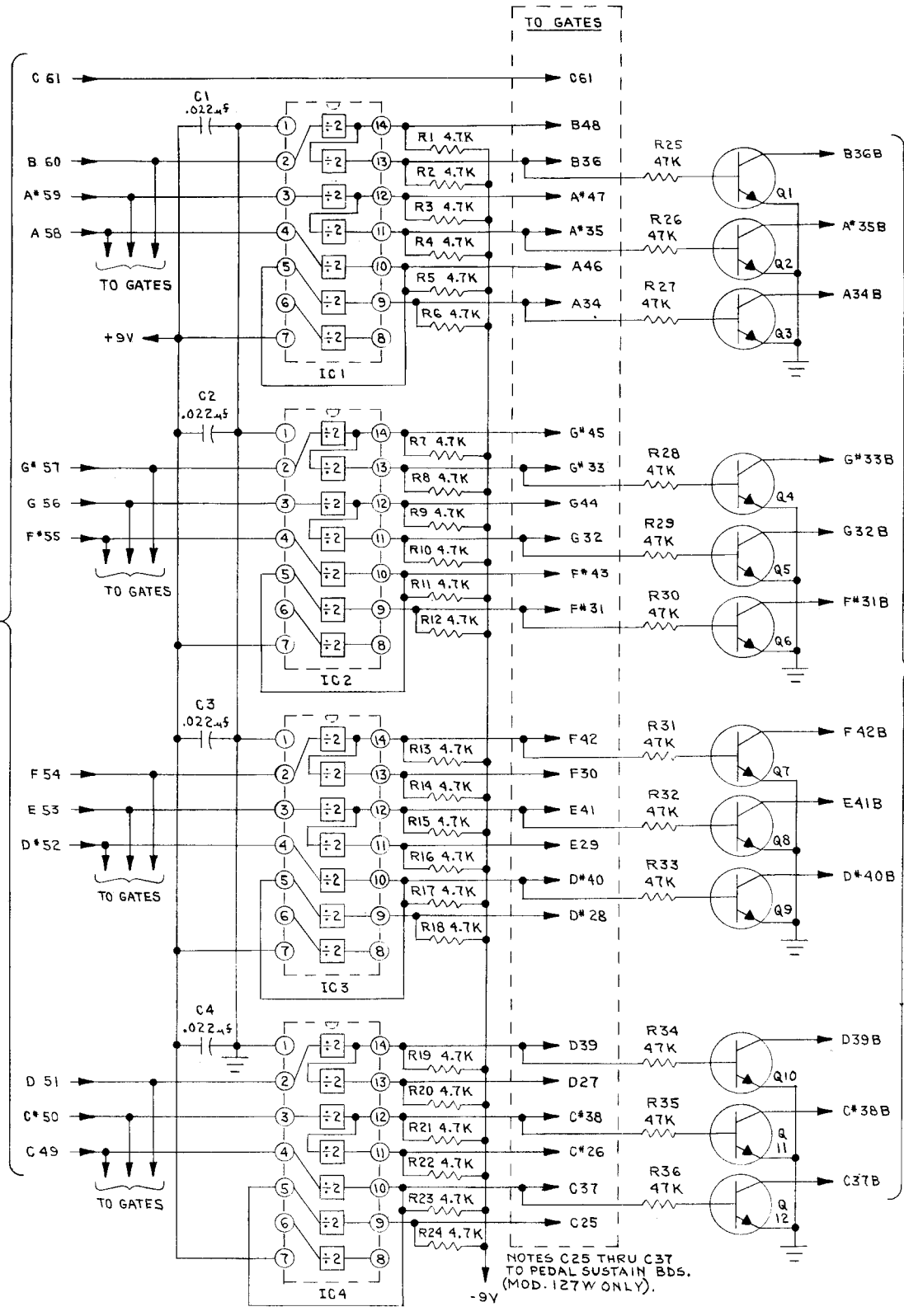

FREQUENCY DIVIDERS
(127 W) AS14-061735
(127 F) AS14-047801

REF. R501-060684

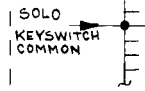

NOTE BUFFERS TO F. M. LOGIC BD.
REF. R501-100779

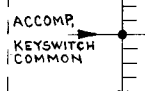
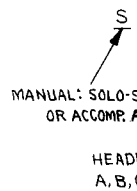

RIGHT SOLO

NOTE 1. ALI

DATE 10-3-73	
PRINT	CIN.
DISTRIBUTION	S
ALL DRAWINGS AND SPECIFICATIONS RETURNED TO IT. ALL SPECIFICATIONS TO WHOM THEY ARE SENT, WHICH MAY BE FURNISHED OTHERWISE AS IN ANY MANNER OR PERMISSION TO MANUFACTURER.	
UNLESS OTHERWISE SPECIFIED	

RELEASED

Ord. No. R.N. 650
Date 1/31/74

RECORD OF CHANGE

- A C4 WAS 2.2 μ F 20V
C.N. 15,760 M.S. 2-27-74
- B ADDED NOTES 1 & 2
C.N. 16,532 2-2-76 DRB
- C C1, C2, C3 & C4 WERE
.02 μ F CERAMIC.
DELETED NOTE 2.
C5 & C6 WERE TANT.
CHANGED FOR RADIAL
LEAD CAPACITORS.
C.N. 18,170 E.J.L. 1-9-79

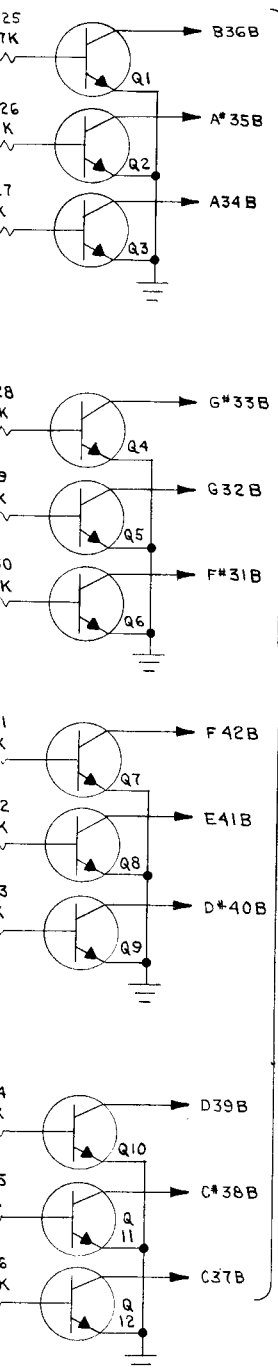

NOTE BUFFERS TO F.M. LOGIC BD.
REF. R501-00077g

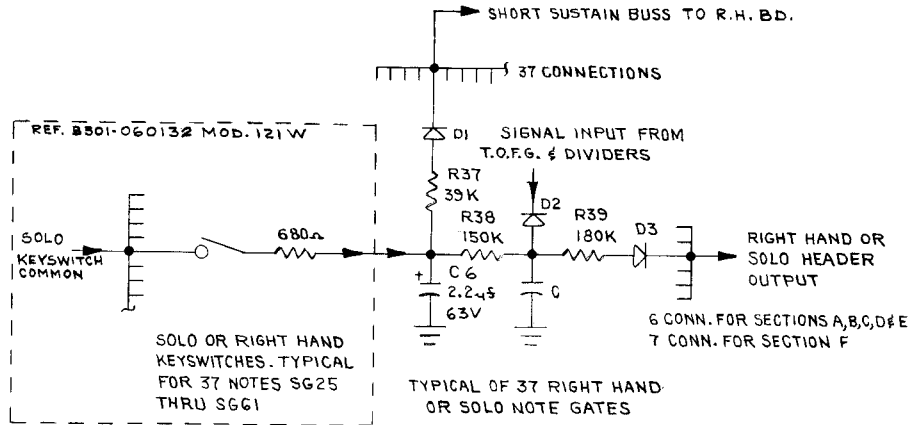

HEADER OUTPUT SECTION	GATE NUMBER	VALUE OF C IN MFD
S F T	61, 60	.0018
A F T	59, 58, 57	.0022
	56, 55	.0027
S E G	54, 53	.0027
A E G	52, 51, 50	.0033
	49	.0039
S D G	48, 47	.0039
A D G	46, 45, 44, 43	.0047
S C G	42, 41, 40	.0056
A C G	39, 38, 37	.0068
S B G	36	.0068
A B G	35, 34, 33	.0082
	32, 31	.010
S A G	30, 29	.010
A A G	28, 27, 26, 25	.012

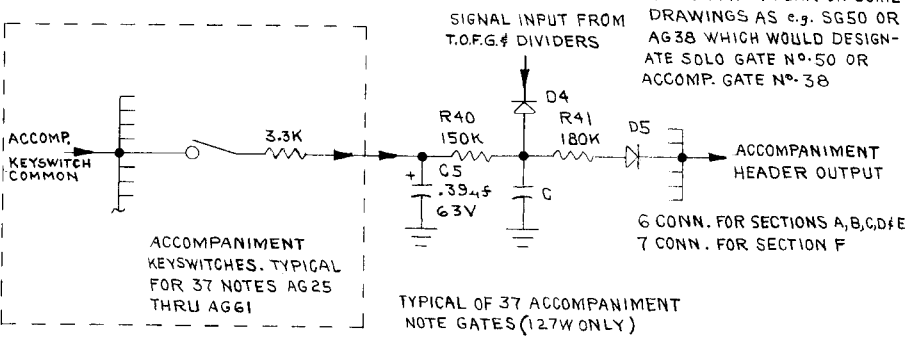

RIGHT HAND REFERS TO MODEL 121W-37 NOTE KEYBOARD
SOLO & ACCOMP. REFER TO MODEL 127W KEYBOARDS

NOTES:
1. ALL RESISTORS ARE 1/4W UNLESS OTHERWISE SPECIFIED.

DATE 10-3-73	DWN. D.DIEHL	CH'D. <i>D.M.</i>	APP'D. <i>Rob.</i>	DWN SCALE	USED ON ORGANS 121W 127W	PART NAME		
PRINT DISTRIBUTION	CIN. S	GR.	CON. 3BL-1BR	FAY. 5BL.	DEQ.	E.P.T.	REQ.	GATE & DIVIDER BD. SCHEMATIC
ALL DRAWINGS AND SPECIFICATIONS ARE AND REMAIN THE PROPERTY OF THE BALDWIN PIANO & ORGAN CO. AND MUST BE RETURNED TO IT. ALL SPECIFICATIONS ARE CONFIDENTIAL AND ARE NOT TO BE DISCLOSED TO ANY PERSONS OTHER THAN THOSE TO WHOM THEY ARE SENT. NO DRAWINGS, SPECIFICATIONS OR OTHER DATA BELONGING TO THE BALDWIN PIANO & ORGAN CO. WHICH MAY BE FURNISHED TO MANUFACTURERS OR OTHERS FOR ANY PURPOSE ARE TO BE REGARDED BY IMPLICATION OR OTHERWISE AS IN ANY MANNER LICENSING THE HOLDER OR ANY OTHER PERSON OR CORPORATION OR CONVEYING ANY RIGHTS OR PERMISSION TO MANUFACTURE, USE OR SELL ANY PATENTED INVENTION THAT MAY IN ANY WAY BE RELATED THERETO.						FINISH	B/M 503-121W-5 GR. NOTED IT.	
UNLESS OTHERWISE SPECIFIED TOLERANCES ARE: DECIMAL \pm .005 FRACTIONAL \pm .015 ANGLE \pm 1/2°						NEXT ASSEM.	SUPERSEDES	
BALDWIN PIANO & ORGAN CO. CINCINNATI, OHIO						REV. C	0501-060143 C	

RELEASED
 Ord. No. R.N. 650
 Date 11/8/74

RECORD OF CHANGE
 A) CHANGE ID. TAPE OF #59
 C.N. 15,714 M.S. 2-4-73
 B) RELOCATED 8 PINS.
 C.N. 15,785 D.LL 3-21-74



DATE 10-5-73		DWN. D. DIEHL		CHD. <i>gfh</i>	APP'D. <i>Rob.</i>	DWN. SCALE FULL	USED ON ORGAN 121	PART NAME		
PRINT DISTRIBUTION	CIN. S	GR.	CON.	FAY. 4BL-1BR	DEQ. 3BL.	E. P. T.	REQ. -	GATE & DIVIDER BD. - WIRING DIAGRAM		
ALL DRAWINGS AND SPECIFICATIONS ARE AND REMAIN THE PROPERTY OF THE BALDWIN PIANO & ORGAN CO. AND MUST BE RETURNED TO IT. ALL SPECIFICATIONS ARE CONFIDENTIAL AND ARE NOT TO BE DISCLOSED TO ANY PERSONS OTHER THAN THOSE TO WHOM THEY ARE SENT. NO DRAWINGS, SPECIFICATIONS OR OTHER DATA BELONGING TO THE BALDWIN PIANO & ORGAN CO. WHICH MAY BE FURNISHED TO MANUFACTURERS OR OTHERS FOR ANY PURPOSES ARE TO BE REGARDED BY IMPLICATION OR OTHERWISE AS IN ANY MANNER LICENSING THE HOLDER OR ANY OTHER PERSON OR CORPORATION OR CONVEYING ANY RIGHTS OR PERMISSION TO MANUFACTURE, USE OR SELL ANY PATENTED INVENTION THAT MAY IN ANY WAY BE RELATED THERETO.							FINISH	BM 503-121-5	GR. NOTED IT.	
UNLESS OTHERWISE SPECIFIED TOLERANCES ARE: DECIMAL ± .005 FRACTIONAL ± .015 ANGLE ± 1/2°							NEXT ASSEM.		SUPERSEDES	REV. B
							BALDWIN PIANO & ORGAN CO. CINCINNATI, OHIO		C 501-060131	B

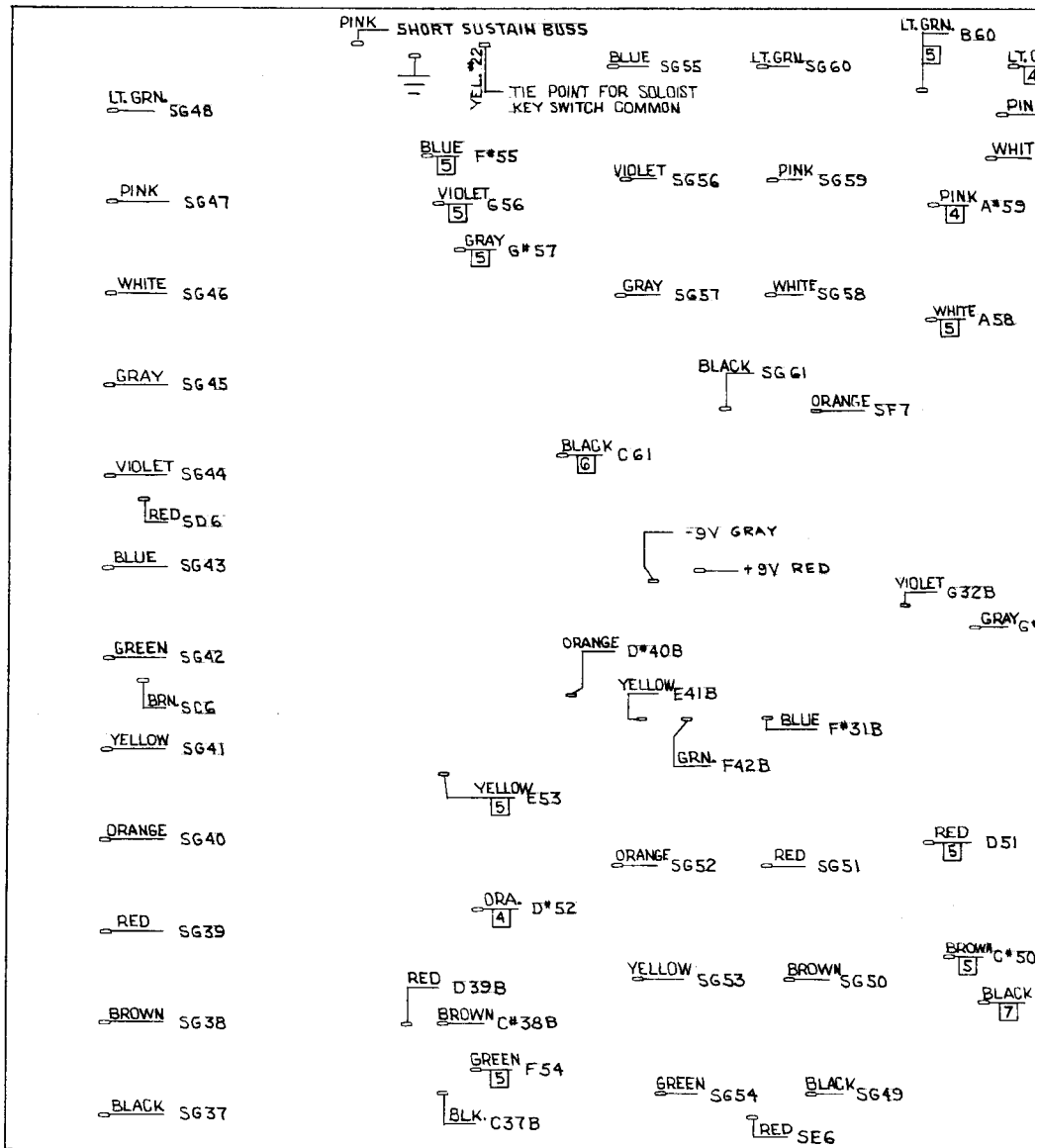

DATE	10-5-73	DWN.	D. DIEHL	CHD.		API
PRINT	CIN.	GR.	CON.	FAY.		DE
DISTRIBUTION	S			481-1BR	3 BL	
<small>ALL DRAWINGS AND SPECIFICATIONS ARE AND REMAIN THE PROPERTY OF THE BALDWIN RETURNED TO IT. ALL SPECIFICATIONS ARE CONFIDENTIAL AND ARE NOT TO BE DISCLOSED TO WHOM THEY ARE SENT. NO DRAWINGS, SPECIFICATIONS OR OTHER DATA BELONGING WHICH MAY BE FURNISHED TO MANUFACTURERS OR OTHERS FOR ANY PURPOSE ARE TO OTHERWISE AS IN ANY MANNER LICENSING THE HOLDER OR ANY OTHER PERSON OR CORP OR PERMISSION TO MANUFACTURE, USE OR SELL ANY PATENTED INVENTION THAT MAY</small>						
<small>UNLESS OTHERWISE SPECIFIED TOLERANCES ARE: DECIMAL ± .005 FF</small>						

FUNMACHINE THEORY

The Fun Machine circuitry can be divided into the following functional circuits:

AUTOMATIC CHORDING CIRCUIT
RHYTHM CIRCUIT
RIGHT HAND CIRCUIT

Following is a brief circuit operation description of the above circuit groups.

AUTOMATIC CHORDING CIRCUIT (LEFT HAND)

The 12 signal frequencies are supplied in groups of 5 to 12 F.M. CHORD SELECTOR HEX INVERTERS, IC3 through IC14. When one key in the Automatic Chording range is played, the hex inverter corresponding to the note played is activated, providing the five frequencies to the following signal busses:

ROOT BUSS
MINOR THIRD BUSS
MAJOR THIRD BUSS
FIFTH BUSS
SEVENTH BUSS

The voltage from the automatic chording keyswitches also operates the NOTE PLAYED DETECTOR circuit, providing a logic level "0" output on the NOTE PLAYED TRIGGER BUSS (A) when only one key is played.

The signals from the above busses are applied directly to four (4) PULSE SHAPER circuits (Q65 through Q68) and via the QUAD 2 INPUT NAND GATE (IC15) and the HEX INVERTER (IC16) to the FIFTH DIVIDER (IC17).

The application of the Seventh signal buss to pulse shaper circuit Q65 is additionally controlled by the function of the KEY SELECTOR SWITCHES.

The ROOT/FIFTH DIVIDER (IC17) divides the incoming signal and provides 8' and 16' signals for the BASS GUITAR PULSE SHAPERS (Q72 and Q73) which, when gated on by the BASS GUITAR TRIGGER AMP (Q71), apply the common signal output to the BASS GUITAR FILTER CIRCUIT. Q71 is triggered on continuously in the ORGAN rhythm pattern mode, or transiently in any other mode by the BASS GUITAR & BASS DRUM TRIGGER, Q18, which is triggered by ROM output #18.

The PULSE SHAPER circuits, Q65 through Q68, supply signal to four (4) diode gate circuits for the following voices:

RHYTHM GUITAR
F.M. PIANO
ELECTRIC GUITAR
F.M. BANJO

The diode gates are rhythmically gated on by the ROM via trigger amplifier circuits controlled by the diode matrix on the rhythm pattern selector switches. The signals from the diode gates are applied to the corresponding active filter circuits of Q55, Q60, Q62 and Q64.

The combined outputs from these filters are connected together with the output of the BASS GUITAR FILTER circuit and are applied via connector P13 to DRUM BALANCE CONTROL potentiometer R2.

RHYTHM

The CLOCK OSCILLATOR, consisting of Q36, Q38 and Q37, supplies strobe pulses to STROBE OUTPUT AMP. Q39, and to the RESETTABLE RHYTHM COUNTER DIVIDERS OF IC2. The operation of the CLOCK OSCILLATOR is controlled by the NOTE PLAYED DETECTOR (Q47 and Q48) via the START/STOP FLIP-FLOP (Q1 and Q3); frequency is controlled manually by means of the TEMPO POTENTIOMETER.

The Strobe Output pulses are applied to the ROM input via rhythm pattern selector switches and the diode matrix. The RESETTABLE RHYTHM COUNTER DIVIDERS of IC2, divide the clock frequency five times, providing the five bit information of A0, A1, A2, A3 and A4 for ROM programming.

The negative pulses appearing at the output Pins #15 through #21 of the ROM are used to trigger the automatic chord voices (left hand, rhythm voices, and right hand voices in PERC. PATTERN II mode.

In PERC. PATTERN I mode of operation, the STROBE OUTPUT AMP., Q39, is used for right hand voice triggering.

In the TOUCH RHYTHM mode of operation, the circuit of Q4 permits the CLOCK OSCILLATOR operation only while the key in the automatic chording range is being depressed.

Counter divider outputs A0, A1, and A3 are used to operate 4/4 - 3/4 CONTROL GATES, Q44 and Q45, in OLD TIME WALTZ and WALTZ rhythm pattern modes. The A3 output is used to operate TEMPO LIGHT FLASH circuit (Q42 and Q43) and the ROOT/FIFTH CONTROL circuit (Q41) in 4/4 time rhythms. The A4 output is used to operate the ROOT/FIFTH CONTROL circuit (Q41) in 3/4 time rhythms of OLD TIME WALTZ and WALTZ patterns.

The +12V REGULATOR circuit of Q40 is utilized for rhythm voice section circuits.

The rhythm voice trigger gates, operated by the ROM, provide a trigger pulse for the following rhythm voice oscillators:

BASS
STRIKE
CLAVE
ACCENT
SNARE
CYMBAL

The Rhythm oscillator outputs are joined together to connect P11 which is connected via R4 to one side of DRUM BALANCE POTENTIOMETER R2. When the DRUM BALANCE PULL-OFF switch is pulled upward, rhythm voices are inhibited from being applied to the preamplifier circuit by the ground application via the switch contacts.

The DRUM BALANCE POTENTIOMETER controls the balance between automatic chord output (left hand) and the rhythm voices.

RIGHT HAND CIRCUIT

Thirty-seven (37) frequencies are applied to individual signal diode gates, and when gated on by the voltage supplied from right hand keyswitches, conduct signals to a three stage LADDER FILTER circuit. Signals from the LADDER FILTER circuit are applied via active filter circuits to the right hand voice diode gate for the continuous voices such as FLUTE, ACCORDION, and TRUMPET, and for the percussive voices of PIANO, GUITAR, HARPSICHORD, and BANJO.

These diode gates are gated by the CONTINUOUS VOICE TRIGGER circuit, Q109, Q108 and Q113, and by the PERCUSSIVE VOICE TRIGGER circuit Q110, Q111, and Q116, via the voice selector switches when a key in the right hand keyboard is depressed.

In ASR mode of operation, voice diode gates are also gated on selectively (See F.M. RHYTHM PATTERN VOICE SELECTION CHART) by +27V applied via rhythm pattern selector switches and the diode matrix.

When not in ASR mode, the above ASR gating paths are inhibited by the clamping action of CONTINUOUS VOICE ASR CLAMP, Q107, and PERC. ASR CLAMP, Q115.

Percussive voices are also triggered by ROM output #20 when in PERC. PATTERN II mode, and the STROBE OUTPUT AMPLIFIER Q39 at the clock rate when in PERC. PATTERN I mode.

The sustain buss of 37 diode gates is controlled by the SHORT/LONG SUSTAIN GATE, Q87. Diode gates are placed in short sustain mode for all voices except VIBRA HARP. In PERC. PATTERN I or II modes, the sustain time for the percussive voice gates (BANJO, PIANO, etc.) is shortened by action of the Q80 when a key in the Automatic Chording range is depressed.

The outputs of all right hand voice diode gates are applied to the RIGHT HAND OUTPUT AMPLIFIER circuit, Q83 and Q84. This output is normally supplied to the organ preamplifier via AUTO MUTE switch contacts and also to the input of the AUTO MUTE circuit. If AUTO MUTE switch is selected, output of the AUTO MUTE circuit from IC 18 is switched to the organ preamplifier. The D.C. voltage from each voice diode gate, applied to AUTO MUTE TRIGGER Q82, will control the muting effect.

AUTOMATIC CHORDING CIRCUIT DESCRIPTION

NOTE PLAYED DETECTOR

The NOTE PLAYED DETECTOR, consisting of Q47, Q48, and associated circuits, provides at its output, (NOTE PLAYED TRIGGER BUSS), a logic level "1" (+5V) when no key or more than one key in the Automatic Chording keyboard range is depressed, and logic level "0" (0V) when only one key is depressed.

This logic level information, identified by (A), is supplied to the following circuits:

ROOT ONLY CONTROL (Q70)
4 HEX INVERTERS (IC16, Inputs 3, 13, 9 and 5)
START/STOP FLIP-FLOP (Base of Q3)
KEY RELEASE DAMP CONTROL (Q52)
PERC. PATTERN SHORT SUSTAIN INHIBIT (Q81)

With no keys in the Automatic Chording keyboard range depressed, there is no base current available for Q47, which will remain off so that the NOTE PLAYED TRIGGER BUSS (A) will be at the "1" logic level (+5V via R222). When a key is depressed, +5V, via associated keyswitch contacts and resistor (R200 through R211) will apply current through R221 to the base of Q47, causing it to saturate, thus, placing the NOTE PLAYED TRIGGER BUSS (A) at "0" (0V) logic level. Some current also flows through D38 and the parallel combination of R219 and R220, but is insufficient to create enough forward bias to turn transistor Q48 on. If more than one key is played, the additional current is supplied by additional keyswitch resistors to the parallel network of R219 and R220, creating sufficient bias to turn on Q48. In this case, the base of Q47 would be shunted to ground, causing it to unsaturate and provide a logic "1" at NOTED PLAYED TRIGGER BUSS (A).

Resistor R219 is factory selected so that Q48 turns on when 1-1/2 keys are played at the same time.

AUTOMATIC CHORDING & KEY SELECTORS

Twelve (12) frequencies (F#31 through F42) are supplied to twelve (12) F.M. CHORD SELECTOR HEX INVERTERS (IC13 through IC14) in groups of five (5) (Root, Minor Third, Major Third, Fifth and Seventh) to form the major or minor triad or seventh chords corresponding to the key played in the automatic chording keyboard range.

The CHORD SELECTOR HEX INVERTERS employ Type 7405 integrated circuits, which contain six (6) independent inverters with "open-collector" outputs.

The "open-collector" indicates that the output terminal is the collector of a transistor without any internal bias supply. The logic "0" output state is a saturated transistor which clamps the output to ground. The logic "1" is effectively an open circuit representing a cut off transistor. An external resistor (in our case R316, R312, R310, R315 and R311) must be provided to bring the output to +5V for logic "1". This arrangement allows the connection of many inverter outputs to the same bias resistor, which permits grounding of the signals (logic "0") on one inverter output without affecting signals of the other inverter outputs.

The +5V supply voltage for these IC's is supplied via the keyswitches of the Automatic Chording range, so when a key is not played, all six outputs of all IC's are open circuits, thus, preventing the input frequencies from passing.

If one key is played, the +5V will be provided for one IC so that the inverters in that package will be activated. All five input frequencies will be inverted by this IC and applied to the appropriate output busses.

For example, if Note B is played, the following conditions will exist:

Note B36	will be inverted by IC14	(Pins 3 to 4)	and will appear on the	ROOT BUSS
Note D39	"	(Pins 5 to 6)	"	MINOR THIRD BUSS
Note D#40	"	(Pins 9 to 8)	"	MAJOR THIRD BUSS
Note F#31	"	(Pins 11 to 10)	"	FIFTH BUSS
Note A34	"	(Pins 13 to 12)	"	SEVENTH BUSS

The sixth inverter input is left open (representing logic "1") so that when a key is played, its output is set to logic "0" level. This information, together with the KEY SELECTOR switches, is used to determine the seventh chord for a particular note played. This operation will be described later.

The ROOT, FIFTH, and SEVENTH signals are applied to PULSE SHAPER circuits Q68, Q66 and Q65, respectively. These signals, together with the THIRD buss, are also controlled by four (4) inverters of IC16, via output Pins 4, 12, 8 and 6. As long as the key is depressed, the NOTE PLAYED TRIGGER buss (A) is at the "0" logic level and is applied to the above inverter inputs (Pins 3, 13, 9 and 5). This sets the inverter outputs to "1" logic level, having no effect on the above signal busses.

The THIRD PULSE SHAPER receives either the MAJOR or MINOR THIRD signal, as determined by the action of the MINOR BAR, MAJOR/MINOR NAND GATES in IC15, and inverter action of IC16. For a detailed description, refer to the MAJOR/MINOR circuit operation paragraph.

The presence of the SEVENTH signal in the chord is controlled by the KEY SELECTOR switches. If none of the switches are depressed, the SEVENTH signal is inhibited by the application of ground from connector E1, via normally closed contacts of the KEY SELECTOR switches and Connector E1 to the SEVENTH BUSS.

In our case, with key "B" depressed, the SEVENTH signal, Note A34, appearing on Pin #12 of IC14 will be inhibited by ground application via E1, KEY SELECTOR SWITCHES, and E3. If any KEY SELECTOR SWITCH is depressed, except C-G^b and F-B, the SEVENTH signal, A34, will not be inhibited. When C-G^b or F-B is selected, the SEVENTH signal, A34, will again be inhibited by IC14 sixth inverter output (Pin #2) of logic level "0", which is applied, via connector E8, and now closed contacts of C-G^b or F-B switches, to the SEVENTH BUSS common output.

The chart below indicates which chords are TRIADS and which chords are SEVENTHS in relation to the selection of the KEY SELECTOR SWITCHES.

		KEY PLAYED											
		C	C#	D	D#	E	F	F#	G	G#	A	A#	B
K E Y S D E E L P E R C E T S O S R E D	NONE	3	3	3	3	3	3	3	3	3	3	3	3
	C-G ^b	3	7	7	7	7	3	3	7	7	7	7	3
	D-A ^b	7	3	3	7	7	7	7	3	3	7	7	7
	E-B ^b	7	7	7	3	3	7	7	7	7	3	3	7
	F-B	7	7	7	7	3	3	7	7	7	7	3	3
	G-D ^b	3	3	7	7	7	7	3	3	7	7	7	7
	A-E ^b	7	7	3	3	7	7	7	7	3	3	7	7

3 indicates TRIAD Chord

7 indicates SEVENTH Chord

ROOT/FIFTH CIRCUIT

A QUAD 2-INPUT NAND GATE with open collector (IC15) and a HEX INVERTER with open collector (IC16) are used for ROOT/FIFTH or ROOT ONLY operations.

IC15 consists of four (4) identical, independent 2-input positive logic nand gates. The logic truth table and logic levels for this device are shown below:

LOGIC LEVELS

"0" = 0V
"1" = +5V

TRUTH TABLE (TYPICAL)

PIN 1 INPUT	PIN 2 INPUT	PIN 3 OUTPUT
1	1	0
0	1	1
1	0	1
0	0	1

The ROOT signal applied to ROOT INHIBIT NAND GATE input Pin #1 is a squarewave containing continuously changing logic levels of "1"s and "0"s (+5V and 0V). Referring to the truth table, it is evident that, when logic level "0" is applied to Pin #2 of the nand gate, the nand gate output at Pin #3 will be set to logic level "1", regardless of the logic level applied to Pin #1. However, with logic level "1" applied to Pin #2 of the nand gate, the output at Pin #3 will be the inverse of the squarewave applied to the input at Pin #1.

Therefore, with logic level "0" at Pin #2, the ROOT signal is inhibited; with logic level "1" at Pin #2, the ROOT signal is allowed to be transferred and inverted by the nand gate.

ROOT ONLY OPERATION

With the ORGAN switch depressed, +27 volts is supplied via the ORGAN switch contacts, connector P4-7, R218, and R308 to the base of Q70, causing it to saturate. The collector of Q70, now at ground potential, disables the ROOT/FIFTH information supplied by Q41 and unsaturates Q69.

The +5V (logic level "1") is supplied via R306 to input Pin #2 of the ROOT INHIBIT NAND GATE, which allows the ROOT signal to be applied to the DUAL J-K FLIP-FLOP ROOT/FIFTH DIVIDER, providing that one key is played in the Automatic Chording range. Logic level "1" (+5V) for IC15 on Pin #2 is, at the same time, inverted by HEX INVERTER IC16 (Pins 11 to 10) to "0" (0V) logic level, which is the inhibit information for the FIFTH signal nand gate. In this mode of operation, only the ROOT signal will be applied to the ROOT/FIFTH DIVIDER.

ROOT/FIFTH OPERATION

The ROOT/FIFTH operation is accomplished by the operation of the ROOT/FIFTH CONTROL, Q41 and Q69, in all rhythm pattern modes of operation except ORGAN. When one key in the Automatic Chording range is depressed, Q70 goes out of saturation allowing the ROOT/FIFTH GATE, Q69, to receive information from ROOT/FIFTH CONTROL Q41, which in turn, receives its information from the rhythm section.

With any of the rhythm pattern switches except OLD TIME WALTZ or WALTZ selected, there is no voltage applied to the 3/4 TIME CONTROL BUSS, and the state of Q41 is determined by the voltage of information bit A3 (IC12 Pin #12).

During the first half of each measure (refer to Drawing No. D579-411), the voltage on A3 buss is +27V: Q41 will be held off via D21, no voltage will be applied to the base of Q69, and the ROOT signal will be passed by the ROOT NAND GATE to the J-K FLIP-FLOP divider.

During the second half of each measure (refer to Drawing No. D579-411), the A3 buss is at +12V: Q41 turns on via D22, D23, and R178, providing saturating voltage for Q69. A logic level "0" (0V) from the collector of Q69 is applied to input Pin #2 of the QUAD 2 INPUT NAND GATE (IC15) and to Pin #11 of the HEX INVERTER (IC16). The input to Pin #2 of IC15 inhibits the Root signal; the input to Pin #11 of IC16 is inverted to logic level "1" (+5V) and applied to Pin #4 of IC15, which permits the FIFTH NAND GATE to operate, allowing the FIFTH signal to appear on the ROOT/FIFTH BUSS.

In 3/4 time operation, when WALTZ or OLD TIME WALTZ rhythm pattern selector switch is selected, the 3/4 TIME CONTROL BUSS is at +27 volts potential, which saturates Q44 and defeats the above mentioned turn on path for Q41 via the clamping action of D24. The state of Q41 is now determined by the voltage of the A4 buss (Pin #13 of IC2). On all odd numbered measures, first, third, fifth, etc. (refer to Drawing No. D579-411), A4 buss is at +27 volts potential. This voltage applied via D25 and R181 will prevent Q41 from turning on. On all even numbered measures, the voltage on A4 buss is +12 volts which will cause Q41 to turn on via R181, R181A and saturated transistor Q44. Now Q41 will supply voltage to ROOT/FIFTH GATE Q69 and fifth signal will be heard as previously described.

It is also important to mention that the action of the ROOT/FIFTH GATE Q69 is inhibited by Q70, which remains saturated via NOTE PLAYED TRIGGER BUSS (A) and R309, until a key in the Automatic Chording keyboard range is depressed.

MAJOR/MINOR OPERATION

When one key in the automatic chording range is depressed, the HEX INVERTER corresponding to the note played provides five (5) frequencies. It then becomes necessary to form either a major chord (C-E-G-A#) or a minor chord (C-D#-G-A#). This function is controlled by the MINOR BAR.

For a major chord, the MINOR BAR, containing a single pole switch with normally open contacts, is not depressed.

A MAJOR THIRD BUSS is supplied to one of the inputs (Pin #9) of the MAJOR THIRD INHIBIT NAND GATE while the other input (Pin #10) receives logic level "1" (+5V) via R313 resistor. This nand gate will operate, applying a major third signal from its output (Pin #8) to the THIRD BUSS PULSE SHAPER, Q67.

The minor third signal is inhibited by the action of the MINOR THIRD INHIBIT NAND GATE, which cannot change its state because both its inputs (Pins #12 & 13) are connected together and are at logic level "1" (+5V) via R313.

The minor chord sounds when the MINOR BAR is depressed. With the MINOR BAR depressed, logic level "0" (ground) is applied to the three connected nand gate inputs (Pins #10, 12 & 13). The major third nand gate will not operate, thus preventing the major third signal from appearing on the THIRD BUSS. The MINOR THIRD NAND GATE will now allow the minor third signal to be applied to HEX INVERTER IC16 (Pins #1 and 2) where it is inverted and applied via the THIRD BUSS to the PULSE SHAPER, Q67.

BASS GUITAR VOICE CIRCUIT

The root or fifth frequency appearing on the ROOT/FIFTH BUSS is applied to the DUAL J-K FLIP-FLOP ROOT/FIFTH DIVIDER IC17 (Type 74107), which is interconnected in such a way as to produce two divider stages; thus, establishing the 8' and 16' Bass Guitar signals for the BASS GUITAR PULSE SHAPERS, Q72 and Q73. The BASS GUITAR TRIGGER AMP., transistor Q71, is normally off, leaving collector resistors R323 and R327 of the BASS GUITAR PULSE SHAPERS without D.C. supply so that Q72 and Q73 are inoperative. In ORGAN mode of operation, Q71 is turned on continuously by the application of +27V via ORGAN switch contacts, connector P4-7, R218, and D35 to its base. The saturated Q71 now effectively provides a D.C. supply of +27V for R323 and R327, enabling Q72 and Q73 to operate as a pulse shaping circuit, providing signals at collectors with a pulse width of 1.5 m sec. These signals are combined by D77 and D78 and are applied to the Bass Guitar passive filter circuit.

In all other modes of rhythm patterns, except ORGAN, Q71 is pulsed on via D11 and R65 by the BASS GUITAR AND BASS DRUM TRIGGER, Q18 transistor, when it is triggered on by the ROM #18 pulse for a duration of 10 ms. The voltage on the CONTINUOUS BASS GUITAR BUSS, in this case, is inhibited by the saturated Q46 transistor. Diodes D11 and D35 operate as blocking diodes.

CONTINUOUS BASS GUITAR AND ROOT ONLY INHIBIT transistor Q46 is saturated by the application of +27V via rhythm pattern selector switches and diode matrix to one of the continuous Bass Guitar and Root Only Inhibit busses, as indicated in the DIODE MATRIX CHART under the CONTINUOUS BASS GUITAR INHIBIT section.

AUTOMATIC CHORDING VOICE CIRCUIT

The four buffer stages, Q68, Q67, Q66 and Q65, convert "root", "third", "fifth" and "seventh" squarewave signals into pulse wave signals, with a pulse width of 1 ms. Each of these buffered stage outputs are applied to the diode gates of the automatic chording voices:

RHYTHM GUITAR
F.M. PIANO
ELECTRIC GUITAR
F.M. BANJO

The common outputs of these diode gates are applied respectively to the active filter circuit inputs of Q55, Q60, Q62 and Q64. The outputs of all voices, via level set resistors and decoupling capacitors, are summed together (including the output of the BASS GUITAR FILTER) and applied via connector P13, through Drum Balance potentiometer R2, connectors P12, J12, P30-7, and R4 to the organ preamplifier.

RHYTHM GUITAR VOICE

The RHYTHM GUITAR DIODE GATES D40 through D47 are gated on by the RHYTHM GUITAR TRIGGER AMP., Q50. This transistor is continuously or transiently turned on, providing +27V supply from its collector to emitter and, via R235, R236, R237 and R238, to the anodes of D40/D44, D41/D45, D42/D46 and D43/D47, respectively.

RHYTHM GUITAR TRIGGER AMP. Q50 is turned on continuously in ORGAN rhythm pattern mode of operation by the application of +27V to its base via ORGAN switch contacts, connector P4-7, D36 and R227.

The transient operation of Q50 is achieved by the action of RHYTHM GUITAR PULSE GATE Q54. When triggered by the ROM #16 negative pulse, Q54 will provide a positive voltage to the base of Q50 via R230, emitter to collector, and R227 for a time period determined by C201 and R229. This time constant is shortened by placing R226 in parallel with R229 when the RHYTHM GUITAR DAMP CONTROL CIRCUIT Q49 and Q51, is operated by the ROM #15 pulse, thus shortening, or damping, the rhythm guitar voice. This is equivalent to the effect created on the regular guitar instrument when damping the sound out by placing a hand across the strings. The operation of that circuit commences when the ROM negative pulse #15 is applied to the base of PNP transistor Q49, which will saturate transiently and supply turn-on voltage to the base of Q51, via R224, emitter to collector, and R225. Transistor Q51 will saturate for a time duration determined by C200 and will place R226 effectively in parallel with R229.

A similar damping effect of the Rhythm Guitar voice is accomplished by the action of the KEY RELEASE DAMP CONTROL, Q52, when the key on the Automatic Chording keyboard is released. The voltage of NOTE PLAYED TRIGGER BUSS (A), when the key is released, is at +5V level and when applied via R233 to the base of Q52, will cause it to saturate. Any bias supplied to the base of Q50 will, in this case, be grounded via R228, D37, and collector to emitter circuit of Q52. The F.M. Piano voice is also damped out by the action of Q52, via R249 and D48.

In certain rhythm pattern modes of operation it becomes necessary to inhibit the Rhythm Guitar voice. This is accomplished by the application of +27 volts from the rhythm pattern switches via the diode matrix and RHYTHM GUITAR DEFEAT BUSS to the RHYTHM GUITAR DEFEAT GATE, Q53, as indicated in the DIODE MATRIX CHART under the RHYTHM GUITAR INHIBIT section.

Transistor Q53, when saturated, will prevent the operation of RHYTHM GUITAR TRIGGER AMP. Q50 by placing its base to ground.

F.M. PIANO VOICE

The F.M. PIANO DIODE GATES, D52 through D59, are gated on by the voltage provided by the collector to emitter circuit of F.M. PIANO TRIGGER AMP. Q57, when it is saturated. Q57 is turned on transiently by the F.M. PIANO PULSE GATE, Q58, and continuously by the voltage applied to the CONTINUOUS PIANO BUSS.

The continuous operation of the F.M. Piano voice is accomplished by the application of a positive voltage to the base of Q57 via R253, the diode matrix, and Rhythm Pattern selection switches. See the DIODE MATRIX CHART under CONTINUOUS F.M. PIANO section.

For transient operation of F.M. PIANO TRIGGER AMP., Q57, the F.M. PIANO PULSE GATE, Q58, is incorporated. The voltage supply for the emitter and base of Q58 is supplied by R251 and R252, respectively, via the F.M. PIANO ADD BUSS, diode matrix and Rhythm Pattern switches, thus allowing the transient operation of this stage only in some rhythm patterns. For its operation, refer to the DIODE MATRIX CHART under the TRANSIENT F.M. PIANO section.

The application of the ROM Pulse #17 via D49 to the base of Q58 causes it to saturate, providing the base voltage for Q57, which turns on PIANO DIODE GATES D52 through D59, as previously described.

The sustain of the F.M. PIANO voice is determined by C207 and R254. As in the case of Rhythm Guitar, if a key is released, Q52 is saturated, which effectively shunts R254 with D48 and R249, providing a very short sustain. This eliminates the sustain when a key is released.

In the FOX TROT rhythm pattern only, the sustain time of the F.M. PIANO voice is prolonged by the action of the PIANO SHORT SUSTAIN circuit of Q56 and R250. When FOX TROT switch is depressed, +27V otherwise supplied via switch contacts and R248 to the base of Q56, will be removed. Q56 will unsaturate, disconnecting R250 from the parallel connection of R254, thus prolonging the sustain time for Q57.

Additional triggering of the F.M. PIANO voice is accomplished by the circuit of Q59, whenever the chord that is being heard contains the seventh signal. The ROM output buss #18 is applied via D50 to the junction of R255 and R256. In the absence of a seventh signal, Q59 is cut off, opening a current path for D50 and the ROM #18 pulse. Therefore, ROM #18 pulse has no effect on the state of Q58. When the seventh signal is present on the SEVENTH BUSS, it is rectified by D51, filtered by C208, and applied to the base of Q59 via R257, causing it to saturate. Now when the ROM output #18 supplies a negative pulse, transistor Q58 will turn on, providing a bias for Q57 and F.M. PIANO DIODE GATES.

ELECTRIC GUITAR VOICE

The ELECTRIC GUITAR DIODE GATES, D61 through D68, when gated on by the ELECTRIC GUITAR TRIGGER AMP., Q61, conduct the chord signals to the ELECTRIC GUITAR ACTIVE FILTER circuit of Q62. This voice is operated percussively only. The operation of ELECTRIC GUITAR TRIGGER AMP., Q61, is achieved by the application of the negative ROM pulse #22 at the time when the bias for its emitter and base circuit, via R271 and R272, respectively, is supplied by the ELECTRIC GUITAR ADD BUSS. Refer to DIODE MATRIX CHART of TRANSIENT ELECTRIC GUITAR section to establish the Rhythm Patterns, in which ELECTRIC GUITAR voice is operated.

F.M. BANJO VOICE

The F.M. BANJO TRIGGER AMP., Q63, operates F.M. BANJO DIODE GATES D69 through D76 in percussive (transient) mode only. Upon reception of the positive bias for the emitter and base circuit, via R286 and R287, respectively, and upon reception of ROM #20 output negative pulse to the base, Q63 turns on, supplying the necessary bias for the F.M. BANJO DIODE GATES. The application of the voltage for the F.M. BANJO ADD BUSS is achieved via the diode matrix in some rhythm pattern modes of operation which can be determined from the DIODE MATRIX CHART under F.M. BANJO TRANSIENT operation.

RHYTHM CIRCUIT DESCRIPTION

Logic voltage levels used for the Rhythm circuits are +27 volts and +12 volts. In the following writeup, reference for these voltage values is given in logic terminology as:

+27V is "0" +12V is "1"

+12 VDC SUPPLY

The +12 volt source is derived from the organ +27 volt regulated supply via resistor divider R173, R175 and the base emitter circuit of Q40 transistor.

START/STOP CIRCUIT

The START/STOP FLIP-FLOP, consisting of Q1 and Q3 and associated circuitry, operates as a bistable flip-flop, with its state controlled by the voltage on the NOTE PLAYED TRIGGER BUSS (A).

With no key played in the Automatic Chording keyboard range, NOTE PLAYED TRIGGER BUSS (A) is +5 volts, which provides base current via R11, R10A, and D3 to hold Q3 in saturation and Q1 cut off. Q1 collector voltage of +27V, supplied via R167, TEMPO POTENTIOMETER, and R168 to the base of Q38, will disable the CLOCK OSCILLATOR.

When any key in the Automatic Chording range is depressed, NOTE PLAYED TRIGGER BUSS (A), which is the only base current available for Q3, becomes ground. Q3 therefore turns off, and its collector voltage applied to the base of Q1, causes it to turn on. When Q1 turns on, a negative pulse is applied to the RESETTABLE RHYTHM COUNTER DIVIDERS START RESET BUSS via D19 and C71, which resets all COUNTER CLOCK DIVIDER outputs to "0" condition, corresponding to the first beat in the measure, or the downbeat. The 1st and 5th CLOCK DIVIDER reset inputs, appearing on Pins #3 and #5, are externally connected together and directly coupled to C71. The 2nd, 3rd, and 4th CLOCK DIVIDER reset inputs are internally connected to Pin #6, and are coupled via D18 to C71. This reset buss separation is necessary for 3/4 time reset operation, which is described under 4/4 and 3/4 CONTROL CIRCUIT paragraph.

When Q1 turns on, a ground is applied to the base of Q38 via the CLOCK START/STOP CONTROL BUSS, R167, TEMPO Control, and R168, allowing the CLOCK OSCILLATOR to operate.

The positive collector voltage of Q3 is supplied via R14, the TOUCH RHYTHM normally closed switch contacts, and R9 to the base of Q4 transistor, causing it to turn on, which effectively places a ground potential at the junction of R11 and R10A resistors. This action will prevent the START/STOP FLIP-FLOP from changing its state to stop mode when a key in the Automatic Chording range is released. However, if in TOUCH RHYTHM mode, this current path for the base of Q4 will be disconnected and the condition of START/STOP FLIP-FLOP will be determined by the NOTE PLAYED TRIGGER BUSS voltage level. The START/STOP FLIP-FLOP will be in start mode as long as a key in the Automatic Chording range is depressed and in stop mode when a key is released.

Components C4 and R10 connected to +27V assure that when the organ power is switched on, the START/STOP FLIP-FLOP initial state will be Q3 on, Q1 off, which is the off state.

CLOCK CIRCUIT

The CLOCK OSCILLATOR, consisting of Q36, Q37, and Q38, operates as a free running multivibrator and is controlled by the output state of the START/STOP FLIP-FLOP. The output of this Flip-Flop is coupled to the clock circuit via R167, the TEMPO potentiometer, and R168 to the base of Q38. The emitter of Q38 is referenced to "0" (+27V) logic level, so with the START/STOP FLIP-FLOP output at "0", Q38 will be held off, thus disabling the oscillator.

When the START/STOP FLIP-FLOP output changes its state from "0" to ground as the key in the Automatic Chording range is depressed, the resulting negative pulse is coupled to the base of Q38 via C73 and R168. Q38 saturates, and its positive going collector voltage is coupled to the base of Q36 via C75, causing Q36 to go out of saturation. This condition will exist for a time period determined by the time constant of C75 and R161. When the charging current of C75 decreases to a point where the voltage across R161 is no longer sufficient to keep Q36 cut off, Q36 will go into conduction again. As Q36 starts conducting, the positive going voltage developed at its collector is coupled via C72 to the base of Q38, thereby unsaturating Q38. Q38 will remain unsaturated for a period of time determined by the time constant of C72, R168 the TEMPO potentiometer and R167. When the charging current of C72 decreases to a point at which the base of Q38 is no longer back biased, Q38 will again saturate and the cycle will repeat itself.

The clock output positive pulses are developed at the collector of Q38 when it conducts. These pulses have a fixed width of 10 ms. The time duration between the clock pulses, determined by the off time of Q38, is adjustable by the TEMPO potentiometer.

Transistor Q37 also unsaturates as Q36 conducts. Q37 provides additional base current for Q38, assuring its full saturation, especially at low frequency settings.

As long as the CLOCK START/STOP CONTROL BUSS is at ground potential, the clock will run as a free running multivibrator.

The clock pulses from the collector of Q38 are applied to the input of the CLOCK DIVIDERS via Pin #4 of the Counter, IC2. In addition, the clock pulses are applied to Q39, an emitter follower which acts as a buffer amplifier and a delay stage. Delay for these pulses, now referred to as "Strobe" pulses, is accomplished by R171A and C76, which puts them slightly behind the clock pulses that are fed into the counter. This slight delay allows the counter to set its next binary address, prior to the time of application of Strobe pulses. The Strobe pulses are fed to the rhythm switch pattern common buss and are directed to the ROM input by the particular Rhythm Pattern switch or switches that are depressed.

RESETTABLE RHYTHM COUNTER DIVIDER CIRCUIT

As previously described, the RESETTABLE RHYTHM COUNTER DIVIDER IC contains six (6) divide-by-two stages. The first divider is not used. The remaining five dividers, the 1st CLOCK DIVIDER through the 5th CLOCK DIVIDER, are used as binary counters which divide the clock oscillator output into a five bit binary address to the ROM. The bits are designated as A0, A1, A2, A3, and A4.

Only a "1" to "0" transition at the input of the dividers causes the divider to change its output state. Also, only the "0" to "1" transition applied to the counter reset input sets the output of the counter to "0". At the same time, the reset input will override any additional input to the counters.

To analyze the action of the Clock Dividers, we will assume that the key on the Automatic Chording range has just been depressed and the clock is running. The first clock pulse, applied to the counters at the same time with the reset pulse from the START/STOP FLIP-FLOP, will not have any effect. The outputs of all counters will remain at "0" level. This is the first beat of the measure or the downbeat.

The next clock pulse (transition "1" to "0") applied to the 1st Clock Divider input will cause it to change its output state from "0" to "1". This corresponds to the second beat of a measure with the count address to the ROM now set to "0", "0", "0", "0", "1". The further progression of these changes is shown on the REAL RHYTHM COUNTING SEQUENCE CHART and on the REAL RHYTHM LOGIC WAVEFORM CHART Drawing No. D579-411. Note that the counters provide 32 different binary addresses before the cycle repeats. Each clock pulse corresponds to a 1/16 note; therefore, two measures of rhythm can be produced during one binary cycle of the counter. This means that a full two measures of rhythm are produced by the Rhythm section before the rhythm pattern repeats itself.

4/4 & 3/4 TEMPO CONTROL CIRCUIT

Alteration of the counter divider counting sequence, from 4/4 time to 3/4 time for WALTZ and OLD TIME WALTZ rhythm patterns is accomplished by Q44, Q45, and associated circuit shown below:

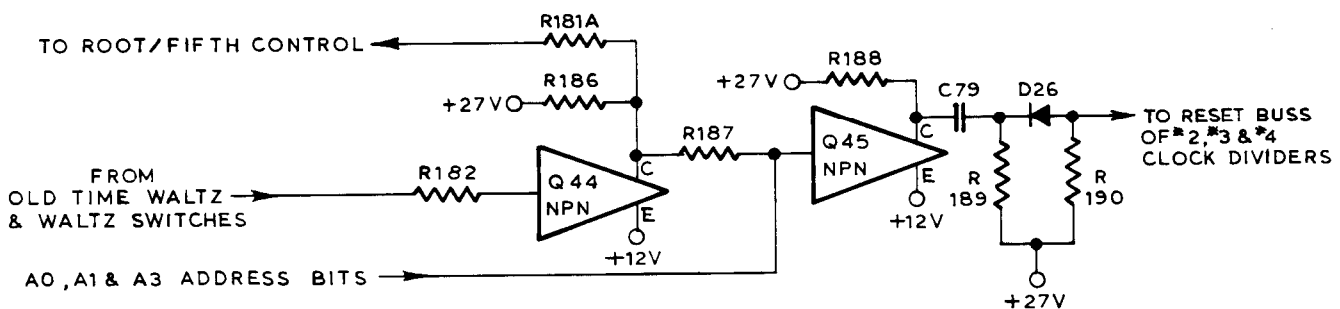

In any Rhythm Pattern mode of operation, except WALTZ or OLD TIME WALTZ, Q44 base does not receive any positive voltage by the 3/4 TIME CONTROL BUSS from the Rhythm Pattern switches; therefore, Q44 remains unsaturated. Its collector positive voltage applied via R187 to the base of Q45 causes Q45 to be saturated. Depressing the WALTZ or OLD TIME WALTZ pattern switches applies a positive voltage, via D185 or D182, to the base of Q44 via R182, causing Q44 to saturate. Now that Q44 is saturated, Q45 loses its base supply and is under the influence of the voltage applied to its base by binary bits A0, A1, and A3 from the counter. When any of the above binary bits are at "0" level, Q45 will saturate; when all three binary bits are at "1" level, Q45 will unsaturate.

Referring to the REAL RHYTHM COUNTING SEQUENCE CHART, it can be seen that between beats #1 and #11, at least one of the address bits (A0, A1 or A3) is at "0" level; therefore, Q45 remains saturated. The first time the above address bits are all at "1" level is on beat #12, at which time Q45 goes out of saturation. This causes the collector of Q45 to change its level from "1" to "0". Diode D26 will prevent this positive voltage transition from being transferred to the counters. However, on beat #13, A0 and A1 both become "0" and Q45 again saturates. The resulting negative excursion at the collector of Q45 is coupled via C79 and D26 to the 3/4 TIME RESET BUSS for counters #2, #3, and #4, causing counters #3 and #4 (A2 and A3) to reset their outputs to "0". Counter #2 (A1) is already at "0" level. Because of the internal connection, when counter #4 (A3) is reset from "1" to "0", counter #5 (A4) output will also change its state from "0" to "1".

Now the new binary address, 1-0-0-0-0, corresponds to beat #17. As a result of this instantaneous circuit action, beat #17 occurs immediately after beat #12. Beats #13, #14, #15, and #16 are therefore skipped. A similar situation occurs on beat #28, causing beats #29, #30, #31, and #32 to be omitted.

The overall effect in omitting the four 1/16 beats on each measure is that the measure is now reduced to twelve (12) 1/16 beats, or 3/4 time.

The TEMPO LIGHT circuit illustrated below consists of Q42, Q43, a solid state indicator (light emitting diode LED), and associated circuitry.

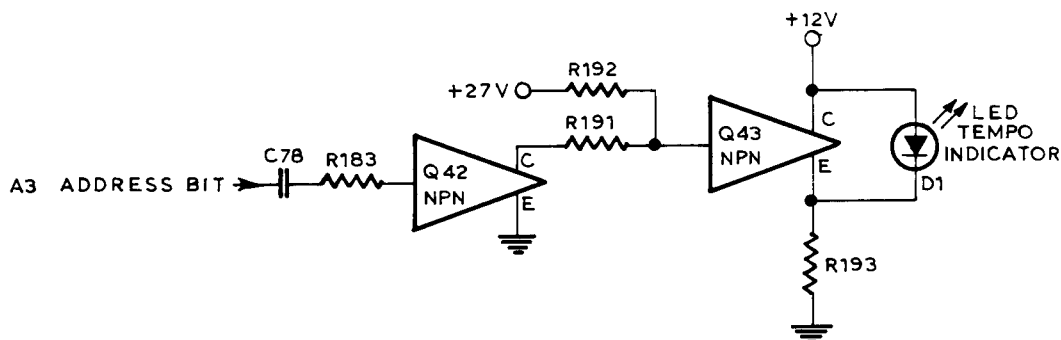

Normally, in the absence of an input signal to Q42, the lamp driver transistor Q43 is saturated by the positive voltage applied to its base via R192 from the +27 volt supply. Under these conditions, the current from the +12 volt supply flows through the saturated transistor and R193. Therefore, there is no forward bias for the LED (D1) and it does not emit light.

The base of normally non-conducting transistor Q42 is connected via C78 and R183 to the output of the 4th Clock Divider, A3 binary bit. Each time A3 changes from "1" to "0" binary state, the positive excursion will pulse Q42 on for a short period of time. As Q42 is pulsed on, Q43 is pulsed off. When Q43 is not saturated, the current from the +12 volt supply will flow through the light emitting diode, D1, causing it to emit light. Q43 and D1 form a constant load on the +12 volt supply, thus, cancelling otherwise undesirable voltage changes (transients) introduced by the load switching.

In summary, the TEMPO LIGHT will flash each time address bit A3 changes from "1" to "0". Referring to the REAL RHYTHM COUNTING SEQUENCE CHART, it can be seen that A3 changes from "1" to "0" when beats #17 and #1 occur. These beats correspond to the downbeat of each measure in 4/4 time. The TEMPO LIGHT will also flash at the correct time when in WALTZ or OLD TIME WALTZ modes because A3 changes state from "1" to "0" at the end of both 3/4 time measures. When the unit is first started by the key depressed in the Automatic Chording range, the TEMPO LIGHT will not flash at the downbeat of the first measure, but it will continue to flash until the unit is shut off or when the TOUCH RHYTHM switch is depressed.

READ ONLY MEMORY (ROM) CIRCUIT

The READ ONLY MEMORY (ROM) acts as a diode matrix. The ROM is programmed for eight (8) different rhythm patterns, and by the help of a diode matrix on the RHYTHM PATTERN selector switches, 16 different rhythm patterns are established.

The STROBE OUTPUT GATE, Q39, supplies the Strobe pulses via selected Rhythm Pattern switches and isolation resistors R149 through R155 to ROM input Pins 2, 3, 9, 10, 11, 12, 14 and 23.

The five bit binary address A0, A1, A2, A3, and A4 provided by the Clock Dividers is applied to ROM Pins 4, 5, 6, 7, and 8. This binary address directs the Strobe pulse, which is inverted by the ROM, to one or more of the eight (8) ROM outputs on Pins #15 through #22. The ROM output busses are applied via resistors to the rhythm voice trigger gates.

The triggers for the above voices can be separately inhibited by the diode matrix busses. The cancellation of these rhythms is shown in DIODE MATRIX CHART.

The progression of the ROM output trigger pulses to the rhythm voices on each beat of the 1st and 2nd measures for all rhythm patterns is indicated on the F.M. RHYTHM MASTER PATTERN CHART No. D579-410.

RHYTHM VOICE CIRCUITS

The RHYTHM VOICE circuits contain a noise source used for the BRUSH, CYMBAL, and SNARE DRUM voices, as well as a series of gated-on oscillators used for the BASS, CLAVE, ACCENT, STRIKE, and SNARE DRUM voices.

The BASS, STRIKE, CLAVE, and ACCENT oscillators and their gates operate identically, therefore, only one of these voices, the BASS, will be discussed.

BASS TRIGGER GATE transistor Q18 is normally off, leaving collector resistor R66 with no DC path. Therefore, the BASS OSCILLATOR Q18 is inoperative. When a negative ROM #18 pulse is applied to the base of Q18, Q18 saturates for a period of time determined by the input pulse. This effectively provides a D.C. path for R66, enabling Q19 to function as an oscillator.

When Q18 is no longer held in saturation, C34 gradually charges through Q19 until the charge is sufficient to cut off Q19. In this manner, the cut off of the oscillator is controlled, with the decay envelope determined by C34 and R68.

The BASS OSCILLATOR output is applied via level set resistor R71 in series with D.C. blocking capacitor C38 to a buss common to all other rhythm voice oscillator outputs, and, then, via R4 to one side of DRUM BALANCE POTENTIOMETER, R2, located on the control panel.

As previously described, Q18, when triggered, on also supplies the necessary trigger voltage, via D11 and R65, for BASS GUITAR TRIGGER AMP. Q71.

The noise circuit, consisting of noise source stage Q32 and the high pass amplifier Q33 through Q35, is the signal source for the CYMBAL, BRUSH, and SNARE DRUM rhythm voices.

The CYMBAL sound is achieved by simultaneously gating on two noise gates and the STRIKE OSCILLATOR GATE. CYMBAL TRIGGER GATE Q22, when triggered, saturates Q24 and Q28 by applying positive voltage through R88 and R107 to their bases. Q24 and Q28 supply ground paths for noise amplifier stages for Q25 and Q29, respectively, allowing them to operate. Q25 applies its noise output to the high frequency amplifier circuit of Q26-Q27, while Q29 applies its noise output to the lower frequency amplifier Q30-Q31. Outputs from both amplifiers are resistively summed to a common point and then, via level set components, applied to the common RHYTHM OUTPUT BUSS.

When triggered, Q24 also supplies a negative trigger to STRIKE TRIGGER GATE Q20, which, together with STRIKE oscillator Q21, operates identically as the previously described Bass circuit.

Operation of CYMBAL TRIGGER GATE Q22 can be inhibited in some Rhythm Pattern modes (See DIODE MATRIX CHART) when transistor Q23 is saturated by the application of the positive voltage to its base, via Rhythm Pattern switches and diode matrix.

When BRUSH TRIGGER GATE Q5 is triggered, it turns on Q6 to complete the emitter circuit of Q7, which feeds noise via D5, C12, and buffer stage Q8 to the output.

The remaining rhythm voice to be discussed is the SNARE DRUM. The SNARE DRUM sound is obtained by simultaneously gating on the SNARE BRUSH and DRUM voices. When a negative pulse is applied to the base of Q9, and its emitter and base receive supply voltage by rhythm switches, it saturates transiently, providing the positive trigger for Q12 via R38 and a D.C. path for DRUM OSCILLATOR Q13 via D7, enabling it to oscillate.

When Q12 saturates, it provides a D.C. path for noise amplifier Q10, enabling it to supply its noise output to Q8 via D6. Q8 is the common noise amplifier for the BRUSH voice and the BRUSH portion of the SNARE DRUM.

The NOISE SOURCE output is adjusted by the level set minipot R129 to give the most authentic SNARE DRUM sound. Once this control has been set, the level of the BRUSH and CYMBAL cannot be changed without destroying the authenticity of the SNARE DRUM voice.

The BRUSH portion of the SNARE DRUM is inhibited by the SNARE (NOISE) INHIBIT GATE, Q11, when some Rhythm Patterns are selected: Refer to DIODE MATRIX CHART. The SNARE (NOISE) INHIBIT GATE, Q11, is saturated by the positive voltage applied to its base via switch contacts and via the diode matrix. The collector of Q11, in this case, will remove the trigger pulse from the base of Q12, therefore disabling the BRUSH portion of the SNARE DRUM sound.

The output of all voices, via level set resistors and decoupling capacitors, are summed together and applied via R4 to DRUM BALANCE potentiometer R2 and, via its wiper, to the preamplifier.

As previously mentioned, the RHYTHM OUTPUT BUSS can be grounded via DRUM BALANCE switch contacts when it is switched on (up position), thus preventing the Rhythm voices from being applied to the preamplifier.

Approximate readings for the Rhythm voice circuits are given in the chart below:

RHYTHM VOICE	STAGE	FREQUENCY	DURATION OF OSCILLATION
BASS	Q19	111 Hz	50 ms
CYMBAL	Q29-Q30-Q31	Lower Freq. Noise	1.0 Sec.
	Q25-Q26-Q27	Higher Freq. Noise	1.0 Sec.
	Q21	5555 Hz	3.5 ms
CLAVE	Q17	2000 Hz	20 ms
BRUSH	Q7-Q8	White Noise	65 ms
ACCENT	Q15	250 Hz	30 ms
SNARE DRUM	Q10-Q8	White Noise	110 ms
	Q13	238 Hz	40 ms

The NOISE SOURCE, Q32-Q35, supplies approximately 200 mV (P-P) of white noise to the NOISE BUSS when the minipot is set at maximum C.W. position.

Real Rhythm Counting Sequence Chart

Measure	4/4-Time Rhythms			Count Address Inputs To ROM					3/4-Time Rhythms		
	1/4 Notes	16th Notes	ROM Address Number	A ₄	A ₃	A ₂	A ₁	A ₀	ROM Address Number	16th Notes	1/4 Notes
1 ↓	1	1	1	0	0	0	0	0	1	1	1
		2	2	0	0	0	0	1	2	2	
		3	3	0	0	0	1	0	3	3	
		4	4	0	0	0	1	1	4	4	
	2	5	5	0	0	1	0	0	5	5	2
		6	6	0	0	1	0	1	6	6	
		7	7	0	0	1	1	0	7	7	
		8	8	0	0	1	1	1	8	8	
	3	9	9	0	1	0	0	0	9	9	3
		10	10	0	1	0	0	1	10	10	
		11	11	0	1	0	1	0	11	11	
		12	12	0	1	0	1	1	12	12	
	4	13	13	0	1	1	0	0	NOT USED		
		14	14	0	1	1	0	1			
		15	15	0	1	1	1	0			
		16	16	0	1	1	1	1			
2 ↓	1	17	17	1	0	0	0	0	17	1	1
		18	18	1	0	0	0	1	18	2	
		19	19	1	0	0	1	0	19	3	
		20	20	1	0	0	1	1	20	4	
	2	21	21	1	0	1	0	0	21	5	2
		22	22	1	0	1	0	1	22	6	
		23	23	1	0	1	1	0	23	7	
		24	24	1	0	1	1	1	24	8	
	3	25	25	1	1	0	0	0	25	9	3
		26	26	1	1	0	0	1	26	10	
		27	27	1	1	0	1	0	27	11	
		28	28	1	1	0	1	1	28	12	
	4	29	29	1	1	1	0	0	NOT USED		
		30	30	1	1	1	0	1			
		31	31	1	1	1	1	0			
		32	32	1	1	1	1	1			

CIRCUIT WAVEFORMS DURING 3/4 TIME OPERATION

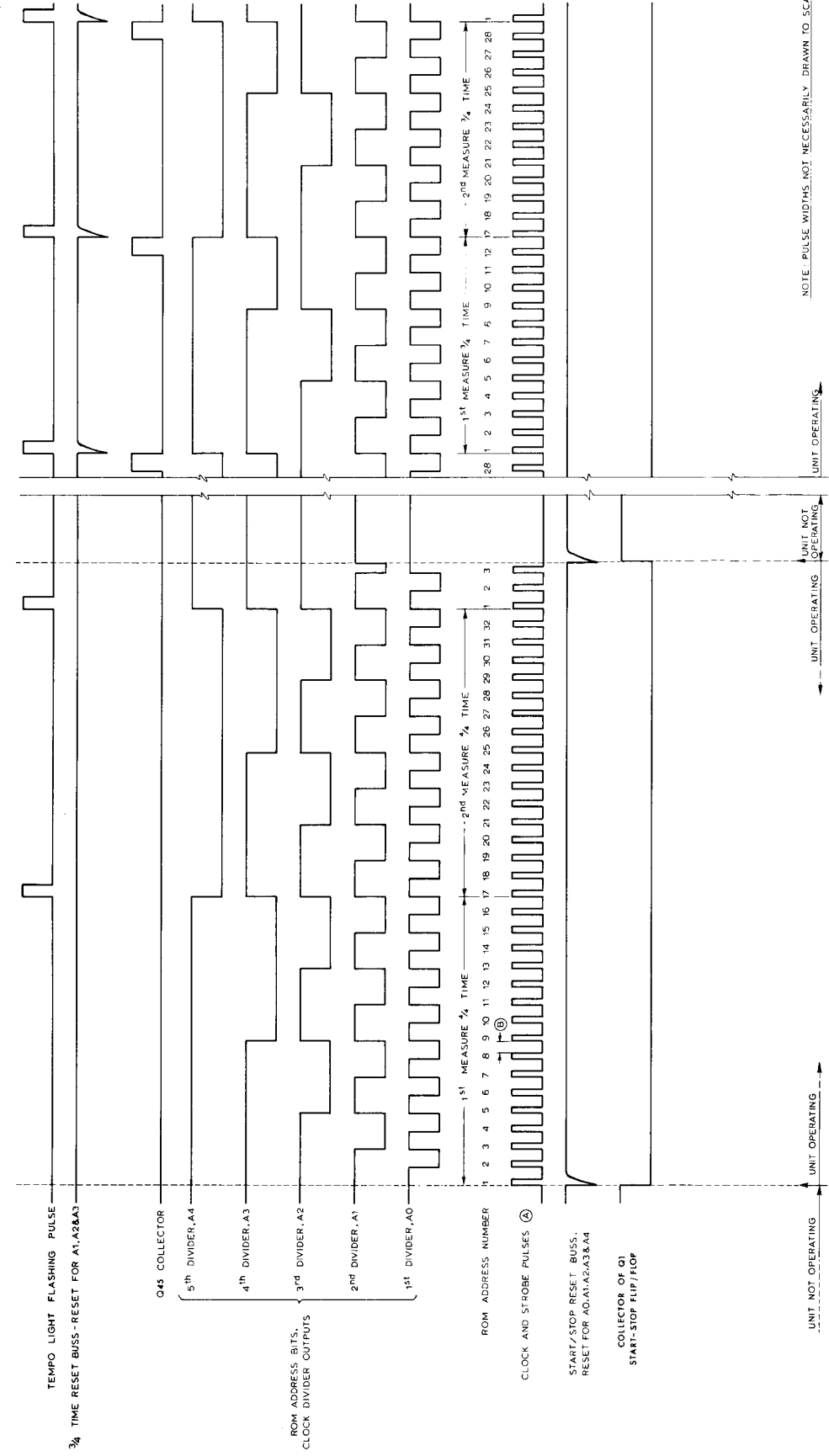

NOTE: PULSE WIDTHS NOT NECESSARILY DRAWN TO SCALE.

- (A) - STROBE PULSES ARE SLIGHTLY DELAYED BEHIND CLOCK PULSES
- (B) - TIME PERIOD BETWEEN CLOCK PULSES SET BY TEMPO CONTROL

DATE	TIME	BY	REASON	APPROVED	TESTED	REVISION	DESCRIPTION
1974	9-3-74	1	...

UNIT NAME REAL RHYTHM
 LOGIC WAVEFORM CHART

TEST MANAGER: ...
 TEST ENGINEER: ...
 TEST OPERATOR: ...
 TEST ROOM: ...
 INSTRUMENTS: ...
 TEST EQUIPMENT: ...
 TEST PROCEDURE: ...
 TEST RESULTS: ...
 TEST CONCLUSION: ...

UNIT OPERATING: D 579-411

RIGHT HAND CIRCUIT DESCRIPTION

SIGNAL SOURCE

Thirty-seven (37) frequencies, C25 through C61, generated on the TOP OCTAVE FREQUENCY GENERATOR (T.O.F.G.) BOARD assembly are conducted to thirty-seven (37) individual DIODE GATE circuits located on the GATE AND DIVIDER BOARD assembly. The state of these DIODE GATES is controlled by thirty-seven (37) keyswitches in the RIGHT HAND keyboard range.

These diodes are "gated on" by application of +14 volts via R565, R567, and a 680 ohm keyswitch resistor when a key or keys are depressed in the RIGHT HAND keyboard range. The outputs of the DIODE GATE circuits are collected in five (5) headers (groups) of six (6) diode pairs each and one (1) header consisting of seven (7) diode pairs. This header output is further applied to a THREE SECTION LADDER FILTER circuit.

The following chart illustrates the signal grouping and distribution:

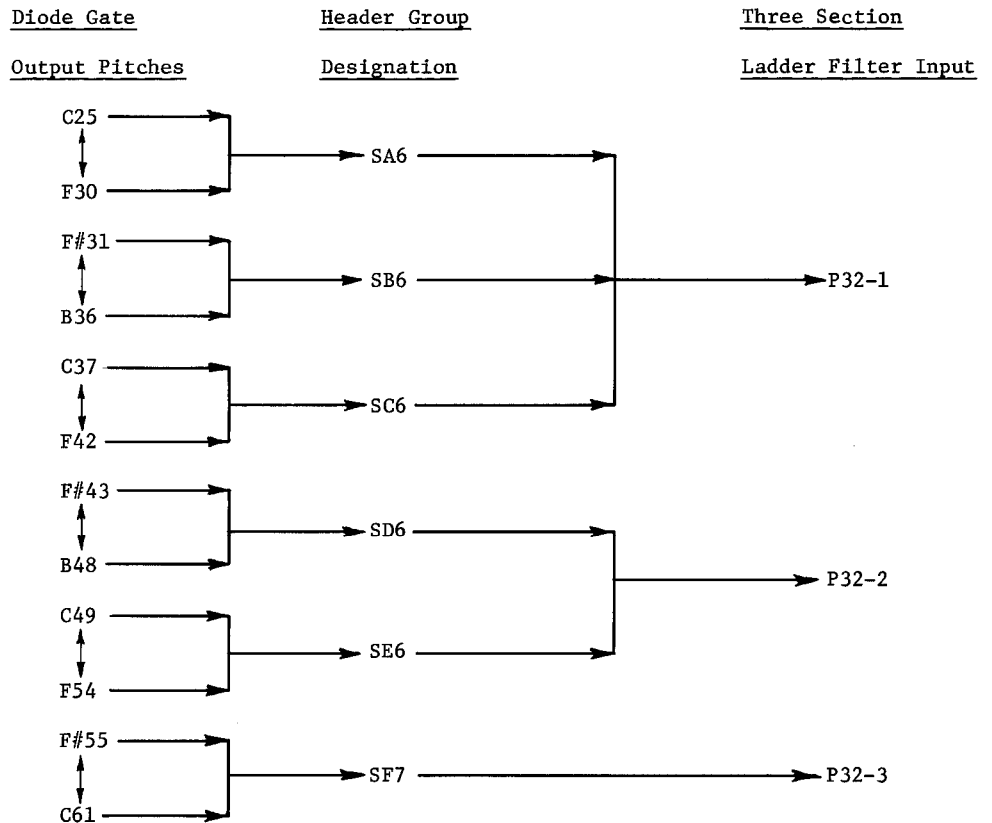

The THREE SECTION LADDER FILTER contains two outputs: one supplies the FLUTE ACTIVE FILTER circuit of Q78 and Q79; the other, the ACCORDION ACTIVE FILTER circuit of Q77. The ACCORDION FILTER circuit is the source for all other right hand voice active filter circuits, Q74, Q75, and Q76.

The FLUTE FILTER circuit of Q78 and Q79 supplies its output, via C444 and R484, to the FLUTE DIODE GATE consisting of D101, D102, and associated components. The ACCORDION FILTER, Q77, supplies its output, via C439 and R474, to ACCORDION DIODE GATE D98/D99 and, also, via C400, C406 and C413, to active filter circuits Q74, Q75, and Q76, respectively.

The TRUMPET AND PIANO FILTER, Q74, output is supplied via R406 and C403 to the TRUMPET DIODE GATE, D79/D80, and via C405 and R407 to PIANO DIODE GATE D81/D82.

The GUITAR AND HARPSICHORD FILTER, Q75, output is supplied via C411 and R414 to GUITAR DIODE GATE D84/D85, and via C410 to HARPSICHORD DIODE GATE D88/D89. The BANJO FILTER, Q76, output is supplied via C416 to BANJO DIODE GATE D94/D95.

When a key or keys in the right hand keyboard range are depressed, all of the above voice diode gates are gated on via voice selector switches and continuous or percussive trigger circuits, which will be discussed later.

CONTINUOUS VOICE TRIGGER CIRCUIT

The CONTINUOUS VOICE TRIGGER circuit, consisting of Q109, Q108, Q113 and associated components, creates a positive voltage when a key in the Right Hand range is depressed. This voltage is supplied via the common buss on the FLUTE, ACCORDION, and TRUMPET selector switches to the corresponding diode gate circuits.

When a key in the Right Hand range is depressed, a current path is established from the +14 volt source via R565 and R567 through the KEYSWITCH COMMON BUSS. A voltage drop across R565, caused by this current, will provide a turn-on bias for Q109. The +14 volts applied by Q109 emitter to collector circuit via R566 to the base of Q108 will cause Q108 to saturate. When Q108 saturates, its negative collector excursion will be coupled via D134 to the base of Q113. Except when in ASR mode of operation, Q113 is permitted to operate by the application of base and emitter supply voltage via R577, R578, and the normally closed ASR switch contacts. When Q113 saturates, it will provide gating voltage for CONTINUOUS VOICE DIODE GATES via the voice selector switches. Capacitor C483 slows the voltage rise at the collector of Q113, which helps to lessen the thump on the attack of the voice.

FLUTE, ACCORDION AND TRUMPET VOICES

The positive voltage supplied by Q113, when a key in the Right Hand range is depressed, is supplied via connector P5-1 to normally open switch contacts of the above voices. With FLUTE, ACCORDION, or TRUMPET voices selected, this positive voltage is coupled to the corresponding diode gates via the following circuit paths: with FLUTE voice selected, via D192, connector P5-3, D104 and R488; with ACCORDION, via connector P5-2, D109, D106 and D479; and with TRUMPET, via connector P5-4, D112, D113 and R448.

As long as the key in the Right Hand range is depressed, these voice diode gates will be continuously gated on via the described circuit paths.

The signal or signals corresponding to the key or keys depressed will be supplied by the signal diode gates via LADDER FILTER and voice active filters, will be gated through the selected voice diode gate, and will be applied to the RIGHT HAND OUTPUT AMPLIFIER circuit of Q83 and Q84.

The SIGNAL DIODE GATE SUSTAIN BUSS for the above voices is placed in short sustain mode by the saturated SHORT/LONG SUSTAIN GATE, Q87. The saturation voltage for Q87 is the +27 volt source, applied to its base via normally closed contacts of the ASR and VIBRA HARP switches, connector P5-5, and R532.

When the key is released, the above voices will not be heard (sustained), because the signal diode gates are operating in a short sustain mode, thus, disabling the signal source for voice diode gates.

FLUTE, ACCORDION AND TRUMPET VOICES ASR MODE

In the ASR mode of operation, the CONTINUOUS VOICE TRIGGER circuit is defeated and the gating of the voice diode gates is accomplished by the voltage supplied by the ASR busses.

Depressing the ASR switch removes the supply voltage for emitter and base circuit of Q113 which is necessary for CONTINUOUS VOICE TRIGGER circuit operation. Even if the Right Hand voice switches are selected, Q113 will not be able to reproduce a trigger pulse to gate the voice diode gates.

The signal diode gate will be maintained in a short sustain mode by the saturated Q87, which now receives its saturation voltage from the +27 volt source, via the closed ASR switch contacts, R531, and R530.

When not in the ASR mode, the gating voltage supplied by the FLUTE, ACCORDION, and TRUMPET ASR busses to the corresponding diode gate circuits is inhibited by the clamping action of the CONTINUOUS VOICE ASR CLAMP transistor, Q107, through D108, D111, and D114. In the ASR mode, the +27 volt saturation voltage for Q107 is removed via the ASR switch contacts, D128, and R562. This defeats its clamping action for these busses.

Referring to the DIODE MATRIX CHART ASR section, whenever the +27 volts is applied via the diode matrix and described ASR busses, the specific voice diode gate will be gated on. When a key on the Right Hand keyboard is depressed, the signal will be applied and gated through such diode gates. These ASR busses are selective and are controlled by the Rhythm Pattern switches. Further information on the ASR voice selection by the Rhythm Pattern modes is supplied in a FUN MACHINE RHYTHM PATTERN AND VOICE SELECTION CHART.

VIBRA HARP VOICE

The FLUTE DIODE GATE circuit is used for FLUTE and/or VIBRA HARP voices. However, the VIBRA HARP gating voltage will always override the FLUTE if both voices are selected simultaneously.

When the Vibra Harp voice is selected, +27 volts is applied via ASR switch contacts, D193, and connector P5-3 to the FLUTE DIODE GATE, causing it to be gated on continuously. VIBRA HARP switch contacts will also remove the voltage from the base of Q87, causing it to unsaturate and place the Signal Diode Gates in long sustain mode.

Now, if a key on the Right Hand keyboard is depressed, the signal will be conducted by the already gated on FLUTE DIODE GATE and applied to the output circuit. After the key is released, due to the long sustain of signal diode gates and continuous gated on condition of the FLUTE DIODE GATE, the signal will slowly die away.

VIBRA HARP ASR MODE

In the Vibra Harp ASR mode of operation, the continuous gating voltage for the FLUTE DIODE GATE and saturation voltage for Q89 is removed by now open ASR switch contacts. Transistor Q89 will unsaturate and remove the ground clamp from the junction of R535 and D105, permitting the FLUTE DIODE GATE to be gated on by the voltage applied by the VIBRA HARP ASR TRIGGER BUSS in certain Rhythm Pattern modes (See DIODE MATRIX CHART). That positive voltage is also applied, via R533 to the base of Q88, causing it to saturate, placing the ground clamp at the junction of R530 and R531. Positive voltage, otherwise supplied by ASR switch contacts, R531, and R530 to the base of Q87, will be removed, causing Q87 to unsaturate, thus, effectively placing the Signal Diode Gates in long sustain mode, which is the right condition for the Vibra Harp voice.

PERCUSSIVE VOICE TRIGGER CIRCUIT

The PERCUSSIVE VOICE TRIGGER circuit, consisting of Q110, Q111, Q116, and associated components, creates a positive trigger voltage transiently, when a key on the Right Hand keyboard is depressed. This trigger pulse is supplied, via percussive voice PIANO, GUITAR, HARPSICHORD, and BANJO selector switches to their voice diode gates. Transistor Q110 is normally turned on by the forward bias supplied to its base from the +27 volt source via R574 and D238. When a key in the Right Hand range is depressed, a negative pulse is coupled via R570, C468, and D131, to the base of Q110, causing it to cut off for the duration of the pulse. Ground clamp from the junction of R568 and R572 will be removed, permitting Q111 to be saturated by the application of +14 volts source to its base, via now saturated Q109. A negative voltage excursion at the collector of Q111, coupled to the anode of D238, removes the base bias for Q110 which holds this transistor off until C471 recovers from this negative pulse through R574. This 10 ms pulse supplied to the base of Q116 will cause Q116 to saturate, thus, producing a positive 10 ms pulse, which is slowed down by C485 in order to lessen the thump on the attack of the voice.

In the ASR mode, the operation of Q116 is defeated by removal of its base and emitter voltage supplied by ASR switch contacts to R582 and R583.

PERCUSSIVE VOICES

The sounding of the percussive voices, when a key in the Right Hand range is depressed, is accomplished by the application of the positive pulse created by Q116 to the percussive voice diode gate inputs via Connector P5-9 and the following circuit paths:

PIANO switch, Connector P5-6, D124, and R450 to PIANO diode gate (anodes of D81 and D82).
GUITAR switch, Connector P5-8, D125, and R456 to GUITAR diode gate (anodes of D84 and D85).
HARPSICHORD switch, Connector P7-2, D127, and R462 to HARPSICHORD diode gate (anodes of D88 and D89).
BANJO switch, Connector P7-3, D126, and R469 to BANJO diode gate (anodes of D94 and D95).

The above voice diode gates will be gated on transiently, thus, the signals supplied via the LADDER FILTER and the active filters will be applied, via a common output to the RIGHT HAND OUTPUT AMPLIFIER circuit of Q83 and Q84.

After the trigger voltage is removed, the sustain capacitor of a particular voice gate, typically C431 for PIANO, will discharge with a double decay rate: first, through R451, D83, and D115 to a voltage of approximately 9 volts (established by R498 and R499), and, then, through a resistor parallel combination such as R447 and R449.

In percussive voice mode of operation, the signal diode gates are placed in a short sustain mode by saturated Q87 in the same manner as previously described.

PERCUSSION PATTERN OPERATION

In the PERCUSSION PATTERN I mode of operation, the STROBE OUTPUT PULSES from the rhythm section, are applied to the base of Q117, via Connector P7-4, PERCUSSION PATTERN I switch contacts, Connector P7-5, R586, and C472. Q117 is turned on by these positive Strobe pulses and provides at its collector a series of negative pulses at the Clock rate, which triggers the one shot (monostable) PERCUSSIVE VOICE TRIGGER circuit, whose operation was previously described.

If a key in the Right Hand range is depressed, these pulses will trigger a voice gate with the same frequency as the rhythm clock.

In PERCUSSION PATTERN II mode, the ROM #20 negative pulse is applied to the circuit of Q110 and Q111 via Connector P7-6, PERCUSSION PATTERN II switch contacts, Connector P7-7, C473, and D136. This provides a series of pulses, corresponding to the internal programming of the ROM and rhythm selected, for percussive voice gate triggering. Also, due to the origin of these triggers, The CLOCK OSCILLATOR must be running.

The triggers supplied to the wipers of PERCUSSION PATTERN I and II switches are also connected to the base of Q80 via P7-5 and R487, or P7-7 and R486 to a common connection. Normally, when a key in the Automatic Chording range is not depressed, Q81 is saturated by the NOTE PLAYED TRIGGER VOLTAGE (A) applied to its base via R491. Thus, the triggers at the junction of R486 and R487 will be clamped to ground, preventing their influence on the state of Q80.

If a key in the Automatic Chording range is depressed, Q81 will unsaturate and the triggers will be applied to the base of Q80, which will turn on. This provides a short sustain mode for the Percussion Pattern operation by providing an additional path to ground, via the Q80 collector to emitter circuit and a diode-resistor series network from the voice diode gate sustain capacitors. This short sustain network consists of D84 and R473 for PIANO, D87 and R473 for GUITAR, R464 and D93 for HARPSICHORD and R471 and D97 for BANJO voice diode gates.

PERCUSSIVE VOICE ASR MODE

When the ASR switch is depressed, the gating of the percussive voice diode gates by the PERCUSSIVE VOICE TRIGGER circuit is defeated. The operation of Q116 is defeated by removing the base and emitter supply voltage normally supplied via the ASR switch contacts, R582, and R583. In addition, PERC. ASR CLAMP transistor Q115 loses its base bias, unsaturates, and allows the pulses from the collector of Q110 to be supplied to the base of PERC. ASR GATE Q114. Normally, when not in the ASR mode, Q114 is cut off, which permits the +27 volt source to be applied by R538 to four (4) ASR trigger gates via R536, R539, R543, and R542, inhibiting their operation by keeping them in an off state. Depending on the rhythm selected (Refer to DIODE MATRIX CHART and F.M. RHYTHM PATTERN & VOICE SELECTION CHART), one or more ASR busses will supply a positive voltage for the emitter and base circuits of Q90, Q91, Q93, or Q92, (e.g., for PIANO ASR TRIGGER Q90, via R537 and R593). When a key in the Right Hand range is depressed, the created positive pulse at the collector of Q110, supplied to the base of Q114 via R580, will cause Q114 to produce a negative pulse. This pulse is now applied to the base of the ASR TRIGGER transistor. Any ASR TRIGGER transistor that has its emitter and base voltage supplied by an ASR buss will pass the pulse, thus providing a gating voltage for its voice diode gate.

RIGHT HAND OUTPUT AMPLIFIER

The RIGHT HAND OUTPUT AMPLIFIER, consisting of Q83, Q84, and associated components, couples the voice diode gate output signals to the organ preamplifier circuit via C451, R518, Connector P6-2, normally closed contacts of AUTO MUTE switch, Connector P6-3, Connector P30-6 and R2. The RIGHT HAND OUTPUT AMPLIFIER is also applied to the signal input point of AUTO MUTE circuit via R547 and C459.

The output signals of all Right Hand voice gates are added to the D.C. bias current that turns the gates on. This current, injected at the emitter of Q83, tends to change the D.C. level at the output of the amplifier and cause thump. To minimize this effect, typically, R520 for the FLUTE DIODE GATE provides a compensating current at the base of Q83.

AUTO MUTE CIRCUIT

When the AUTO MUTE switch is depressed, the AUTO MUTE circuit output is applied to the organ preamplifier input circuit, while the output from the RIGHT HAND OUTPUT AMPLIFIER is disconnected.

The AUTO MUTE circuit is a filter with a variable bandpass characteristic controlled by the bias current of the voice diode gates, which is applied to the base of emitter follower Q82. The circuit consists of two voltage controlled lo-pass filters (Q96, Q97, Q99, Q100 and Q101, Q102, Q105, Q106) control circuitry for these filters (Q94, Q95, Q103, Q104), and an operational amplifier (IC18).

Signals from the RIGHT HAND OUTPUT AMPLIFIER, via R547 and C459, are supplied to the input of the first filter stage, which consists of two differential amplifier pairs (Q96-Q99 and Q97-Q100) connected in parallel to act as a variable resistance, and, in conjunction with C461 and C462, forms a lo-pass filter. Similarly, the next stage, together with C465 forms a second variable lo-pass filter, with its output applied directly to the operational amplifier integrated circuit of IC18.

A feedback loop, consisting of C465, C462, and R550 feeds the output of each section back to the input of the first stage.

When a key is played, the ACCORDION and TRUMPET trigger voltage is applied via D90 and D91 to the shaping circuit of R504 and C445. This provides a trigger with an attack characteristic for the base of emitter follower Q82. Similarly, the PIANO, GUITAR, HARPSICHORD and BANJO supply a trigger voltage, via D120, D121, D122, and D123, to the base of Q82 by the resistor divider R503 and R502. The FLUTE VOICE DIODE GATE is not connected to the AUTO MUTE TRIGGER, Q82, thus FLUTE and VIBRA HARP voices do not have a muting effect.

Q94, a phase splitter, controls the current supplied to the differential amplifier by Q95, Q104 and Q98, Q103 current sources.

The trigger voltage supplied by continuous voice diode gates and percussive voice diode gates are of different characteristics, so their action and application to the base of Q82, an emitter follower, have to be described separately.

For continuous voices, this trigger is applied via R504 to charge C445 and then via D117 to the base of Q82. In this case, the attack will be slow, so that the voltage applied by the emitter of Q82 will slowly rise to maximum. When a key is released, due to the absence of signal from the RIGHT HAND OUTPUT AMPLIFIER, the slow decay of this circuit is of no importance.

For percussive voices, this trigger is divided in half by resistor divider R503 and R502 before it is directly applied to the base of Q82. The attack is fast, while decay will sweep back slowly, causing the emitter voltage of Q82 to rise to maximum value quickly and slowly sweep back. The voltage changes on the emitter of Q82 are applied via R545 to the base of phase splitter Q94.

When the voltage on the base of Q94 is low, Q94 will cut off. Its collector will be highly positive, cutting off Q95 and Q104 so no current will flow to the differential amplifier Q96-Q99 and Q101-Q105, rendering them highly resistive to the incoming signal. Similarly, the emitter of Q94 will be close to ground, cutting off Q98 and Q103, the respective current sources for Q97-Q100 and Q102-Q106, so they will also be in a high resistive state with respect to the signal.

With the voltage applied to the base of Q94, it will cause Q94 to conduct, so that its collector will be less positive and its emitter less negative. This will forward bias Q95-Q104-Q98 and Q103, furnishing current to the differential amplifiers, allowing them to be in a low resistance state with respect to the incoming signal.

Summary of the above action on the voices is a slow attack for continuous voices and a slow decay for percussive voices.

DELAYED VIBRATO CIRCUIT

The operation and delayed action of the Vibrato Oscillator, located on the T.O.F.G. board assembly is under the control of the key played on the Right Hand keyboard range. The circuit description is provided in the front section of this manual, under TOP OCTAVE FREQUENCY GENERATOR AND DIODE GATE THEORY.

DIODE MATRIX CHART

CONTINUOUS BASS GUITAR & ROOT ONLY INHIBIT

RHYTHM PATTERN SWITCH	DIODE MATRIX	COMPONENTS	
COUNTRY	D147	} R216	} To base of Q46
POP ROCK	D156		
SOUL ROCK	D159		
BOSA NOVA	D172		
COUNTRY	D149	} R213	
BOSA NOVA	D170		
OLD TIME WALTZ	D179		
SWING	D140	R212	
HAWAIIAN	D162	} R214	
LATIN III	D165		
FOX TROT	D137	} R215	
POP ROCK	D155		
RHUMBA	D168		
POLKA	D175		
WALTZ	D186		
DIXIELAND	D145	} D39 & R215	
RAGTIME	D146		
HOEDOWN	D152		
MARCH	D177		

RHYTHM GUITAR INHIBIT

DIXIELAND	D145	} R234	} To base of Q53
RAGTIME	D146		
HOEDOWN	D152		
MARCH	D177		

F.M. PIANO (CONTINUOUS)

FOX TROT	} & ORGAN	D137	} D190, ORGAN & R263	} To base of Q57
POP ROCK		D155		
RHUMBA		D168		
POLKA		D175		
WALTZ		D186		
DIXIELAND	} & ORGAN	D145	} D191 ORGAN & R253	
RAGTIME		D146		
HOEDOWN		D152		
MARCH		D177		

F.M. PIANO (TRANSIENT)

FOX TROT	} R251 & R252	D137	} To emitter & base of Q58
POP ROCK		D155	
RHUMBA		D168	
POLKA		D175	
WALTZ		D186	
DIXIELAND	} D39, R251 & R252	D145	
RAGTIME		D146	
HOEDOWN		D152	
MARCH		D177	

ELECTRIC GUITAR (TRANSIENT)

COUNTRY	} R271 & R272	D147	} To emitter & base of Q61
POP ROCK		D156	
SOUL ROCK		D159	
BOSA NOVA		D172	

F.M. BANJO (TRANSIENT)

DIXIELAND	D144	}	R286 & R287	— To emitter & base of Q63
HOEDOWN	D151			
OLD TIME WALTZ	D180			
<u>SNARE DRUM ADD</u>				
ALL RHYTHMS EXCEPT COUNTRY			R33 & R34	— To base & emitter of Q9
<u>SNARE (NOISE) & CYMBAL DEFEAT</u>				
HAWAIIAN	D162	}	R39 R85	— To base of Q11 — To base of Q23
LATIN III	D165			
<u>CLAVE ADD, SNARE (NOISE) & CYMBAL DEFEAT</u>				
RHUMBA	D169	}	D10, R55 & R56 D12 & R39 D12 & R85	— To base & emitter of Q16 — To base of Q11 — To base of Q23
BOSA NOVA	D173			
<u>CYMBAL DEFEAT</u>				
DIXIELAND	R588	}		— To base of Q23
MARCH	R589			
OLD TIME WALTZ	R590			
<u>ACCENT DEFEAT</u>				
COUNTRY	D149	}	D8	— To base of Q14
BOSA NOVA	D170			
OLD TIME WALTZ	D179			
<u>VIBRA HARP ASR</u>				
HAWAIIAN	D164	}	R533	— To base of Q88
BOSA NOVA	D174			
WALTZ	D183			
<u>FLUTE ASR</u>				
FOX TROT	D138	}	R493	— To FLUTE DIODE GATE
POP ROCK	D157			
SOUL ROCK	D160			
RHUMBA	D167			
ORGAN	D187			
<u>ACCORDION ASR</u>				
FOX TROT	D139	}	R495	— To ACCORDION DIODE GATE
SOUL ROCK	D161			
POLKA	D176			
ORGAN	D188			
<u>TRUMPET ASR</u>				
DIXIELAND	D142	}	R497	— To TRUMPET DIODE GATE
LATIN III	D166			
MARCH	D178			
ORGAN	D189			
<u>PIANO ASR</u>				
SWING	D141	}	R593, Q90e-c & R450	— To PIANO DIODE GATE
RAGTIME	D148			
POP ROCK	D154			
RHUMBA	D171			
OLD TIME WALTZ	D181			
<u>GUITAR ASR</u>				
COUNTRY	D150	}	R594, Q91e-c & R456	— To GUITAR DIODE GATE
HAWAIIAN	D163			
<u>HARPSICHORD ASR</u>				
RAGTIME	D143	}	R595, Q93e-c & R462	— To HARPSICHORD DIODE GATE
SOUL ROCK	D158			
WALTZ	D184			
<u>BANJO ASR</u>				
HOEDOWN	D153	—	R596, Q92e-c & R469	— To BANJO DIODE GATE

FUN MACHINE RHYTHM PATTERN & VOICE SELECTION CHART

		FOX TROTT	SWING	DIXIE LAND	RASTIE ME	COUNTRY	HOO DOW	POP ROCK	SOUL ROCK	HAWAIIAN	LATIN III	RHUMBA	BOSA NOVA	POLKA	MARCH	OLD TIME WALTZ	WALTZ	ORGAN
RHYTHM PATTERN	SELECT ROM PIN NO. 2																	
	SELECT ROM PIN NO. 3																	
	SELECT ROM PIN NO. 9																	
	SELECT ROM PIN NO. 10																	
	SELECT ROM PIN NO. 11																	
	SELECT ROM PIN NO. 12																	
	SELECT ROM PIN NO. 14																	
	SELECT ROM PIN NO. 23																	
ASR	FLUTE ASR																	
	VIBRA HARP ASR																	
	ACCORDION ASR																	
	TRUMPET ASR																	
	PIANO ASR																	
	GUITAR ASR																	
	HARPSICHORD ASR																	
	BANJO ASR																	
F.M.	F.M. PIANO ADD																	
	F.M. PIANO LONG SUSTAIN																	
	CONTINUOUS F.M. PIANO (ORGAN SW. ON)																	
	CONTINUOUS BASS GUITAR & ROOT ONLY																	
	CONTINUOUS BASS GUITAR & ROOT ONLY INHIBIT																	
	CONTINUOUS RHYTHM GUITAR																	
	RHYTHM GUITAR DEFEAT																	
	ELECTRIC GUITAR ADD																	
F.M. BANJO ADD																		
RHYTHM VOICE	CLAVE ADD																	
	CYMBAL DEFEAT																	
	ACCENT DEFEAT																	
	SNARE DRUM DEFEAT																	
	SNARE (NOISE) DEFEAT																	
	3/4-TIME CONTROL BUSS																	

F U N M A C H I N E T R A N S I S T O R

F U N C T I O N C H A R T

RHYTHM SECTION VOICE BOARD

- Q1 - Q3 Start/Stop Flip-Flop. Controls the state of Clock Oscillator and resets the counters.
 Stop State: Q1 off, Q3 on. Q3 on via (A), R11, R10A & D3. Start State: Q1 on, Q3 off. Q4 saturates, preventing stop state when F.M. key is released.
- Q4 When key in F.M. is released, Q4 saturates from +27V via R13, R14, Touch Rhythm contacts, and R9, preventing the Start/Stop Flip-Flop from going into stop mode. In Touch Rhythm mode, Q4 is disabled.
- Q5 Brush Trigger Gate. Gated by negative pulse from ROM and saturates Q6.
- Q6 Brush Gate. When gated by Q5, provides ground path for Q7.
- Q7 Noise Source Buffer. When ground path is provided by Q6, noise is applied to Brush Amplifier Q8.
- Q8 Brush Buffer Amplifier Stage.
- Q9 Snare Drum Trigger Gate. When gated by ROM #19, negative pulse saturates Q12 and allows Snare Oscillator Q13 to operate.
- Q10 Noise Source Buffer. When ground path provided by Q12, noise is applied to Brush Amplifier Q8.
- Q11 Snare (Noise) Inhibit Gate. Noise portion of Snare Drum is inhibited by Q11 when HAWAIIAN or LATIN III Rhythm patterns are selected.
- Q12 Snare (Brush) Gate. Gated by Q9, provides ground path for Q10.
- Q13 Snare Oscillator. Gated by Q9, produces frequency of 238 Hz for duration of 40 ms.
- Q14 Accent Trigger Gate. Gated on by #22 ROM negative pulse if not defeated in OLD TIME WALTZ, BOSA NOVA or COUNTRY Rhythm pattern modes. Q14 allows Accent Oscillator Q15 to operate.
- Q15 Accent Oscillator. Gated by Q14, produces frequency of 250 Hz for duration of 30 ms.
- Q16 Clave Trigger Gate. Gated on by #21 ROM negative pulse in RHUMBA and BOSA NOVA Rhythm pattern modes only. Q16 allows Clave Oscillator Q17 to operate.
- Q17 Clave Oscillator. Gated by Q16, produces frequency of 2000 Hz for duration of 20 ms.
- Q18 Bass Guitar and Bass Drum Trigger. Gated by #18 ROM negative pulse. Q18 allows Bass Oscillator Q19 to operate and also triggers Bass Guitar Trigger Amp Q71.
- Q19 Bass Oscillator. Gated by Q18, produces frequency of 111 Hz for duration of 50 ms.
- Q20 Strike Oscillator Trigger Gate. When gated on by Cymbal Gate Q24, allows Strike Oscillator to operate.
- Q21 Strike Oscillator. When gated by Cymbal Trigger gates Q22, Q24 and Q20, produces frequency of 5555 Hz for duration of 3.5 ms.
- Q22 Cymbal Trigger Gate. Gated by #21 ROM negative pulse, Q22 gates on Cymbal gates Q24 and Q28.
- Q23 Cymbal Inhibit Gate. When gated by +27V via Rhythm Buffer switches in HAWAIIAN, LATIN III, RHUMBA, BOSA NOVA, DIXIELAND, MARCH and OLD TIME WALTZ modes, Q23 disables Cymbal Trigger Gate Q22.
- Q24 Cymbal Noise and Strike Gate. Gates on Q20 and Q25.
- Q25 Noise Source Buffer. When gated by Q24, applies noise to Noise Amplifiers Q26 and Q27.
- Q26 & Q27 High Frequency Noise Amplifier.
- Q28 Cymbal Noise Gate. Gates on Q29.
- Q29 Noise Source Buffer. When gated by Q28, applies noise to Noise Amplifiers Q30 and Q31.
- Q30 & A31 Lower Frequency Noise Amplifier.
- Q32 Noise Source.
- Q33 thru Q35 Noise Source Amplifier. Produces 200mV P-P noise voltage at the output when mini-pot R129 is set to maximum.
- Q36 & Q38 Clock Oscillator, operating as free-running multivibrator.
- Q37 Supplies base current for Q38.
- Q39 Strobe Output Amplifier. Buffer Amplifier for Clock pulses to ROM via Rhythm Pattern Selector switches and to Percussion Pattern I switch.
- Q40 +12VDC Supply Source, operating as an Emitter Follower.
- Q41 Root/Fifth Control Gate. Operates Root/Fifth Gate Q69 when Q70 is in off state.
- Q42 & Q43 Tempo Light Flasher Circuit.
- Q44 & Q45 4/4 - 3/4 Control Gates. In WALTZ and OLD TIME WALTZ Rhythm pattern modes, Q44 is saturated. Q45 produces reset pulse of 2nd, 3rd and 4th Clock Dividers and Clock operates in 3/4 mode.

Fun Machine Transistor
Function Chart (Cont'd.)

FUN MACHINE LOGIC BOARD

- Q46 Continuous Bass Guitar and Root Only Inhibit Gate. Removes saturation voltage for continuous Bass Guitar Trigger Gate Q71 in all Rhythm pattern modes. When organ switch is depressed, removes base voltage to Q70 via R308.
- Q47 One Note Played Detector. When one key in Fun Machine range is depressed, Q47 saturates and supplies GND to Note Played Trigger Buss. In unkeyed state buss (A) is at +5V level.
- Q48 Two or More Notes Played Detector. When two or more keys in Fun Machine range are depressed, Q48 saturates and defeats the operation of Q47.
- Q49 First Stage of Rhythm Guitar Damp Control. Gated on by #15 ROM pulse, turning on Q51.
- Q50 Rhythm Guitar Trigger Amp. When triggered, gates on Rhythm Guitar Diode Gates D40 through D57.
- Q51 Second Stage of Rhythm Guitar Damp Control. When gated on by Q49, places additional sustain discharge path for C201 by way of R226.
- Q52 Key Release Damp Control. Saturated by buss (A) voltage when key in Fun Machine range is released, shortening sustain time for Rhythm Guitar voice by placing discharge circuit of R228 and D37 across C201.
- Q53 Rhythm Guitar Defeat Gate. Defeats the operation of Rhythm Guitar gate Q50 in DIXIELAND, RAGTIME, HOEDOWN and MARCH Rhythm pattern modes.
- Q54 Rhythm Guitar Pulse Gate. Operates Rhythm Guitar Trigger Amp Q50 when gated by #16 ROM pulse.
- Q55 Rhythm Guitar Active Filter.
- Q56 Piano Short Sustain Gate. F.M. Piano Trigger circuit in short sustain mode for all Rhythm Patterns except FOX-TROT. Q56 is saturated normally by +27V via FOX-TROT switches.
- Q57 F.M. Piano Trigger Amplifier. When triggered, gates on F.M. Piano Diode Gates D52 through D59.
- Q58 F.M. Piano Pulse Gate. In DIXIELAND, RAGTIME, HOEDOWN, MARCH and WALTZ Rhythm pattern modes Q58 is triggered by #17 ROM pulse and also #18 ROM pulse when Q59 is unsaturated. Q58 supplies triggering voltage to R57.
- Q59 When signal is present on 7th buss, Q59 is saturated, which allows #18 ROM pulse to operate Q58.
- Q60 F.M. Piano Active Filter.
- Q61 Electric Guitar Trigger Amp. When triggered, gates on Electric Guitar Diode Gates D61 through D68.
- Q62 Electric Guitar Active Filter.
- Q63 F.M. Banjo Trigger Amplifier. When triggered, gates on F.M. Banjo Diode Gates D69 through D76.
- Q64 F.M. Banjo Active Filter.
- Q65 Seventh Square Wave to pulse wave signal buffer.
- Q66 Fifth Square Wave to pulse wave signal buffer.
- Q67 Third Square Wave to pulse wave signal buffer.
- Q68 Root Square Wave to pulse wave signal buffer.
- Q69 Root/Fifth Gate. Operated by Q70 in Root Only and Q41 in Root/Fifth mode. Q69 applies its logic output to IC15 and IC16.
- Q70 Root Only Control. When saturated, defeats the operation of Q69. Q70 saturated when in ORGAN mode and when key is not depressed in F.M. range.
- Q71 Bass Guitar Trigger Amp. Operates Q72 and Q73 continuously when saturated in ORGAN mode by +27V via R218 and D35. Q71 also operates transiently via D18 and R65 when Q18 is triggered on by #18 ROM pulse.
- Q72 8' Bass Guitar Pulse Shaper. When gated on by Q71, applies 8' signal to Bass Guitar passive filter.
- Q73 16' Bass Guitar Pulse Shaper. When gated on by Q71, applies 16' signal to Bass Guitar passive filter.

RIGHT HAND BOARD

- Q74 Q74 Trumpet and F.M. Piano Active Header Filter.
- Q75 Guitar and Harpsichord Active Header Filter.
- Q76 F.M. Banjo Active Header Filter.
- Q77 Accordion Active Header Filter.
- Q78 & Q79 Flute Active Header Filter.
- Q80 Percussion Pattern Short Sustain Control. Q80 is saturated in PERC. PATTERN I or II mode when key in F.M. range is depressed. Q80 provides additional discharge path for all percussion voice diode gates, rendering them in short sustain mode.
- Q81 Percussion Pattern Short Sustain Inhibit. Operated by trigger buss A. When key in F.M. range is not depressed, Q81 is saturated and inhibits the operation of Q80.
- Q82 Auto Mute Trigger. Operated by D.C. voltage from diode gates when gated. Q82 provides D.C. control voltage for Auto Mute Circuit.
- Q82 & Q84 Right Hand Output Amplifier. Amplifies the Right Hand Voice Outputs and applies them to the Auto Mute and Preamplifier circuits.

Fun Machine Transistor
Function Chart (Cont'd.)

RIGHT HAND BOARD

- Q87 Short/Long Sustain Gate. Unsaturated in VIBRA HARP and ASR VIBRA HARP modes to provide long sustain mode for diode gates on Gate and Divider board. Q87 is saturated in all other modes via VIBRA HARP switch from +27V and via ASR switch, R531 and R530, rendering the above diodes in short sustain state.
- Q88 Vibra Harp ASR Control. Saturated in HAWAIIAN, BOSA NOVA and WALTZ Rhythm patterns, thus removes the bias voltage for Q87 applied from ASR switch.
- Q89 Vibra Harp ASR Control. Saturated in all modes except ASR. When Q89 is unsaturated, the gate voltage is applied to the Flute Diode Gate via Vibra Harp ASR buss, R535 and D105 in HAWAIIAN, BOSA NOVA and WALTZ rhythm patterns.
- Q90 Piano ASR Trigger. Q90 bias supply is supplied via Piano ASR buss in SWING, RAGTIME, POP ROCK, RHUMBA and OLD TIME WALTZ rhythm path. If triggered by Q114, it supplies gate voltage for Piano Diode Gate.
- Q91 Guitar ASR Trigger. Q91 Bias supply is supplied via Guitar ASR buss in COUNTRY and HAWAIIAN rhythm patterns, and if triggered by Q114, it supplies gate voltage for Guitar Diode Gates.
- Q92 Banjo ASR Trigger. Q92 bias supply is supplied via Banjo ASR Buss in HOEDOWN rhythm pattern, and if triggered by Q114, supplies gate voltage for Banjo Diode Gate.
- Q93 Harpsichord ASR Trigger. Q93 bias supply is supplied via Harpsichord ASR Buss in RAGTIME, SOUL ROCK and WALTZ rhythm patterns, and if triggered by Q114, supplies gate voltage for Harpsichord Diode Gate.
- Q94-95, 98, 103 & 104 Current Sources for Auto Mute differential bandpass amplifiers.
- Q96, 97, 99 & 100 1st Auto Mute differential bandpass amplifier.
- Q101, 102, 105 & 106 2nd Auto Mute differential bandpass amplifier.
- Q107 Continuous Voice ASR Clamp. Q107 is held in saturation from +27V via ASR normally closed contacts, D428, and R562, disabling continuous voice ASR gating busses to gate continuous voice diode gates. Depressing ASR switch, Q107 goes out of saturation, permitting specific ASR busses to gate corresponding continuous voice diode gate. Q107 is also saturated by Q109 if ASR switch is depressed.
- Q108 Part of Continuous Voice Trigger Circuit. When gated on by Q109, causes Q113 to saturate. Also saturates Q107 if ASR switch is depressed.
- Q109 First Stage of Continuous Voice Trigger Circuit. Gated on when key in Right Hand is depressed. When Q109 saturates, it provides positive voltage to control the following circuits:
- a. Saturates Q112 after time constant of C470
 - b. Applies positive voltage to delayed vibrato circuit via D129
 - c. Saturates Q108
 - d. Saturates Q114; Q115 is cut off
- Q110 First Stage of Percussive Voice Trigger Circuit. When key in Right Hand range is depressed, Q110 unsaturates transiently, removing the ground clamp for Q111, allowing it to saturate.
- Q111 Part of Percussive Voice Trigger Circuit. Gated on when Q110 unsaturates, allowing Q116 to saturate and, via C471, reinforce off state of Q110 to establish pulse width of 10 ms.
- Q112 Vibrato Oscillator Start/Stop Control. Gated on by Q109 via delayed action of C470, removes vibrato oscillator disabling voltage applied from +27V via R576 and D133.
- Q113 Continuous Voice Trigger Circuit Output Stage. When gated on by Q108, provides gating voltage to the continuous voice switches via P5-1.
- Q114 Percussion ASR Gate. When Q115 is unsaturated, Q114 is gated on by Q109, providing negative pulse which triggers on percussive voice. ASR triggers Q90 through Q93.
- Q115 Percussion ASR Clamp. Disables input gating voltage to Q114 unless ASR switch is depressed.
- Q116 Percussive Voice Trigger Circuit Output Stage. When gated on by Q111, provides 10 ms gating pulse to the Percussive voice switches via P5-9.
- Q117 Percussion Pattern Trigger Amp. When pulsed on by strobe pulses in PERC. PATTERN I mode, Q47 triggers Q116 on.

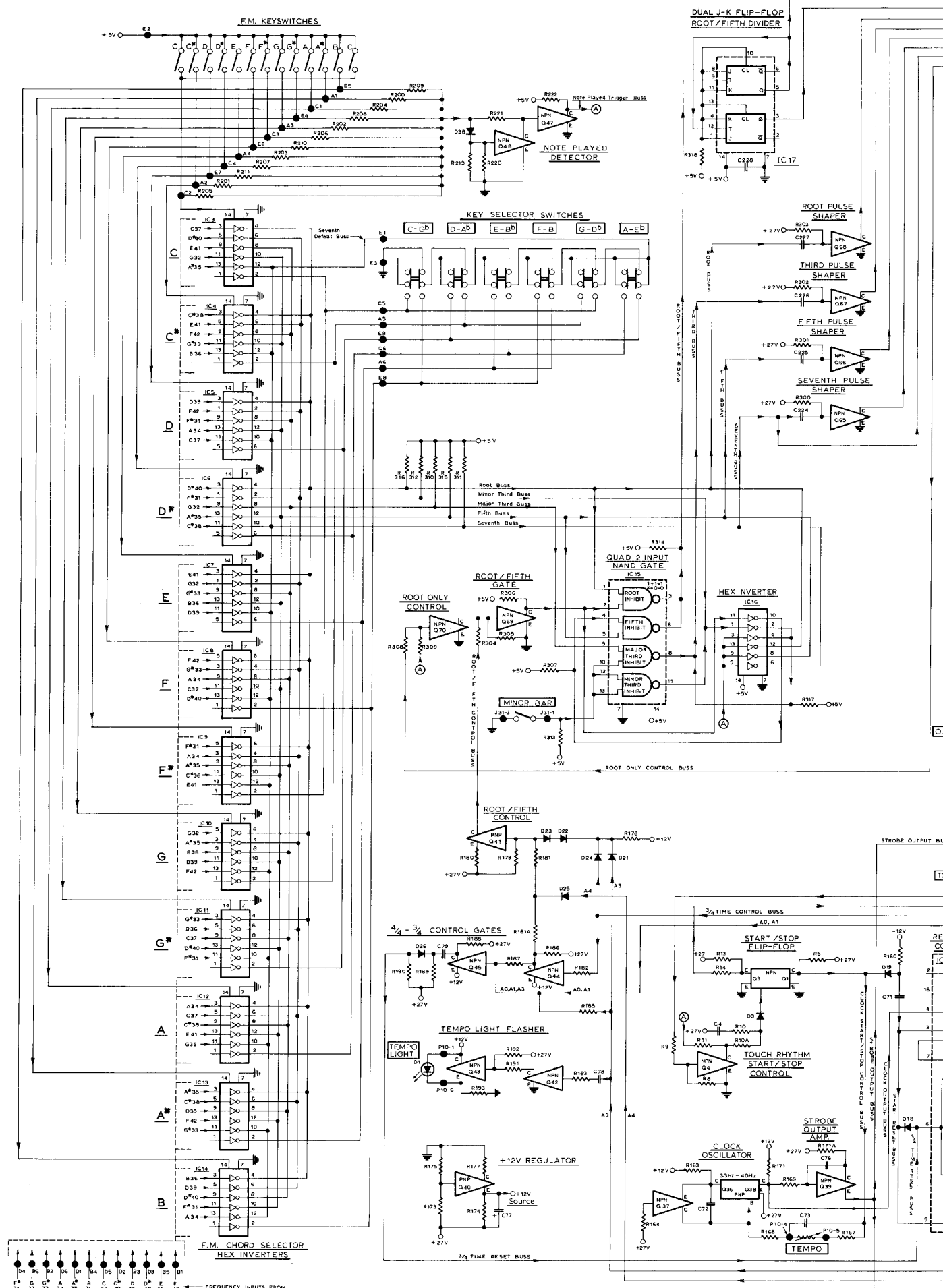

F4 G4 B4 D4 C4 A4 E4
 F3 G3 B3 D3 C3 A3 E3
 F2 G2 B2 D2 C2 A2 E2
 F1 G1 B1 D1 C1 A1 E1

FREQUENCY INPUTS FROM GATE & DIVIDER BOARD CS01-060143

FR
 E
 RZ
 CR
 HC
 FC
 SO
 HA
 LA
 BR
 BC
 E
 LV
 OLD T
 W
 Q
 TOUCH

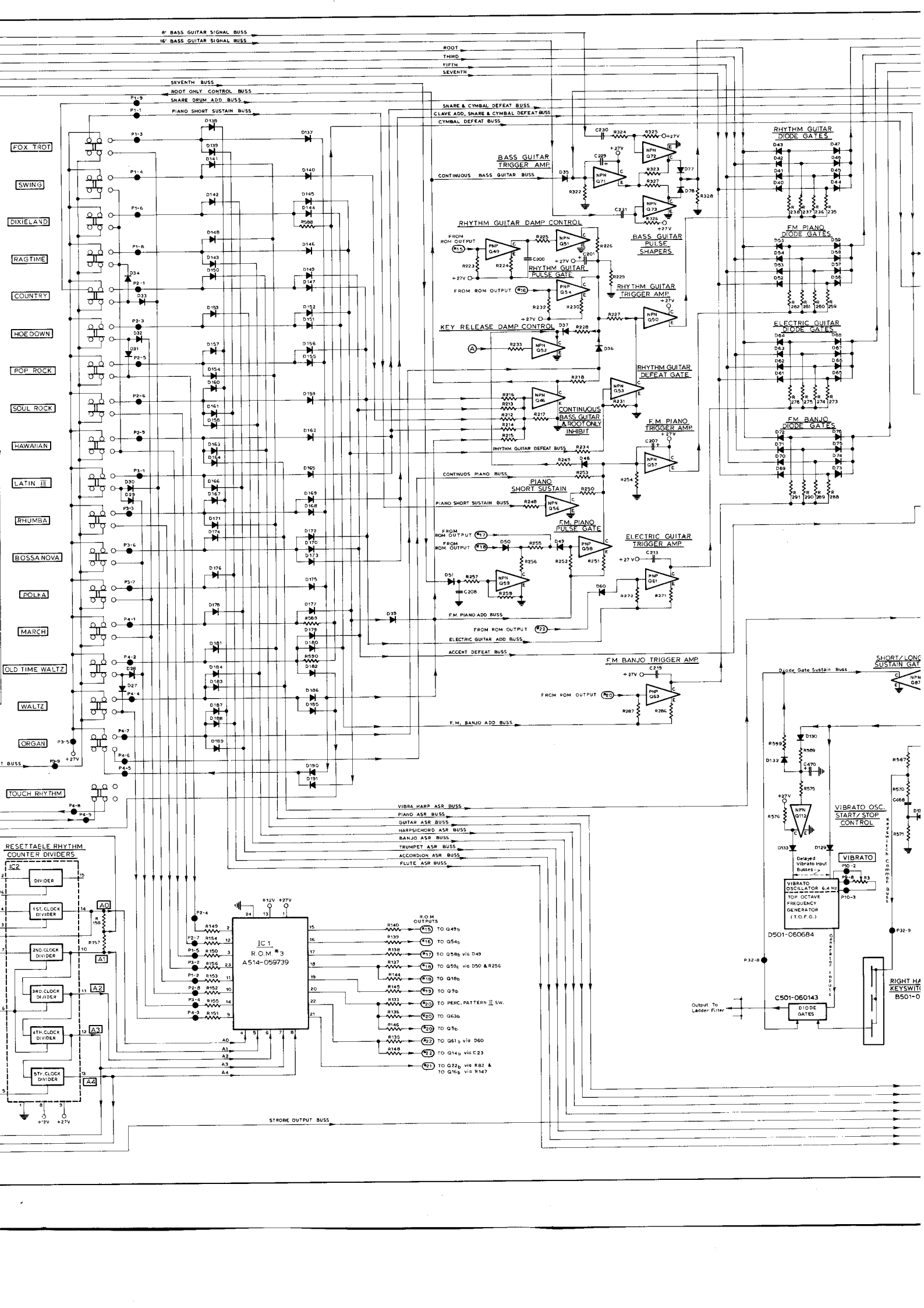

8" BASS GUITAR SIGNAL BUSS
16" BASS GUITAR SIGNAL BUSS

ROOT
THIRD
FIFTH
SEVENTH

SEVENTH BUSS
ROOT ONLY CONTROL BUSS
SNARE DRUM ADD BUSS
PIANO SHORT SUSTAIN BUSS

SNARE & CYMBAL DEFEAT BUSS
CLAVE ADD, SNARE & CYMBAL DEFEAT BUSS
CYMBAL DEFEAT BUSS

- FOX TROT
- SWING
- DIXIELAND
- RAGTIME
- COUNTRY
- HOE DOWN
- POP ROCK
- SOUL ROCK
- HAWAIIAN
- LATIN III
- RHUMBA
- BOSSA NOVA
- POLKA
- MARCH
- OLD TIME WALTZ
- WALTZ
- ORGAN
- TOUCH RHYTHM

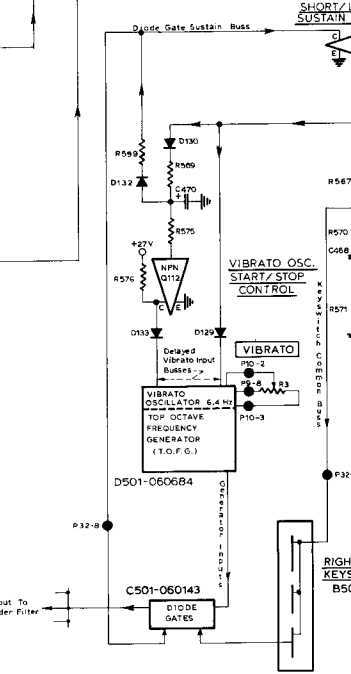
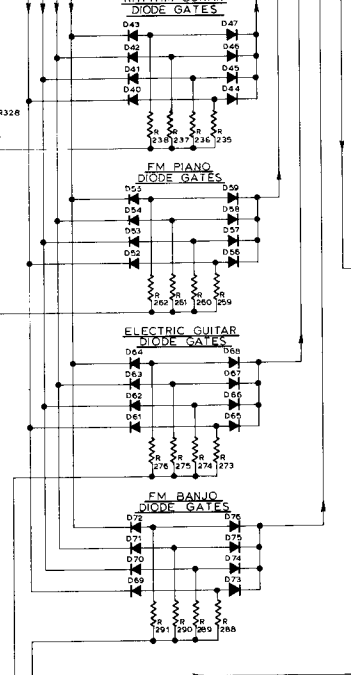
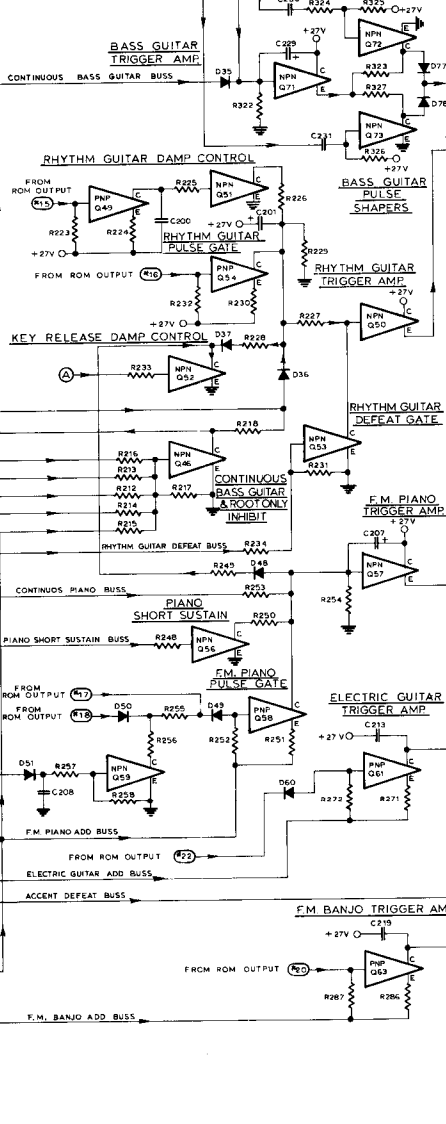
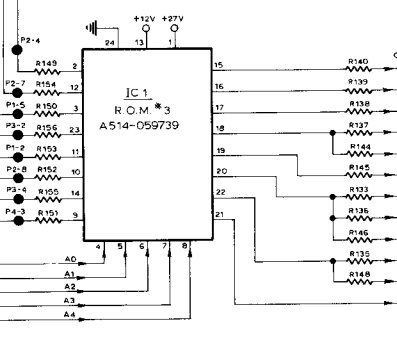
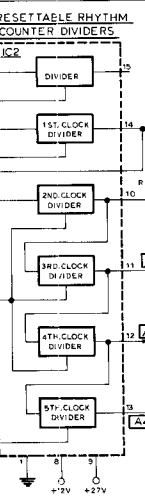

STROBE OUTPUT BUSS

Output To Ladder Filter

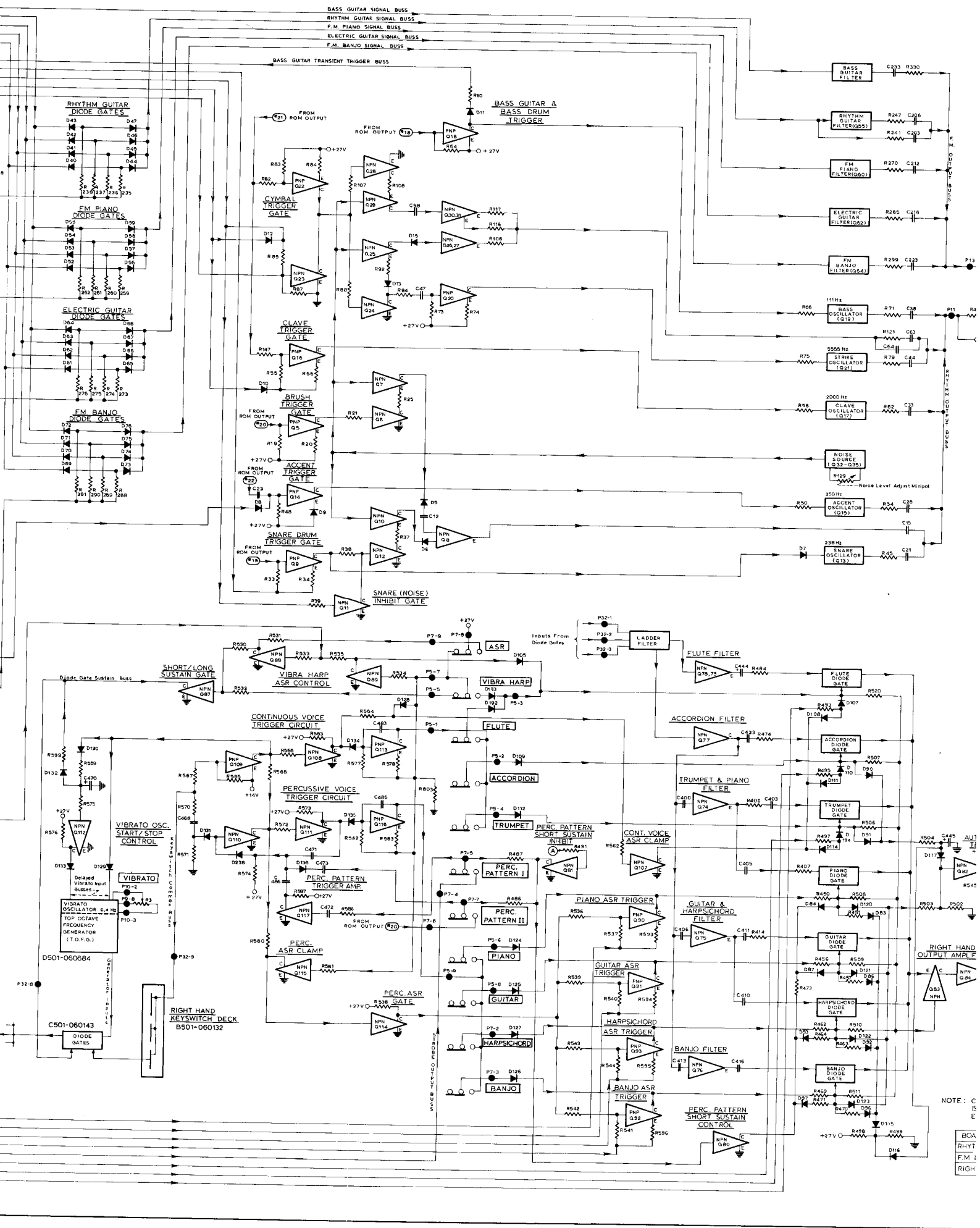

NOTE: C IS E BGA RHYT F.M. i RIGH

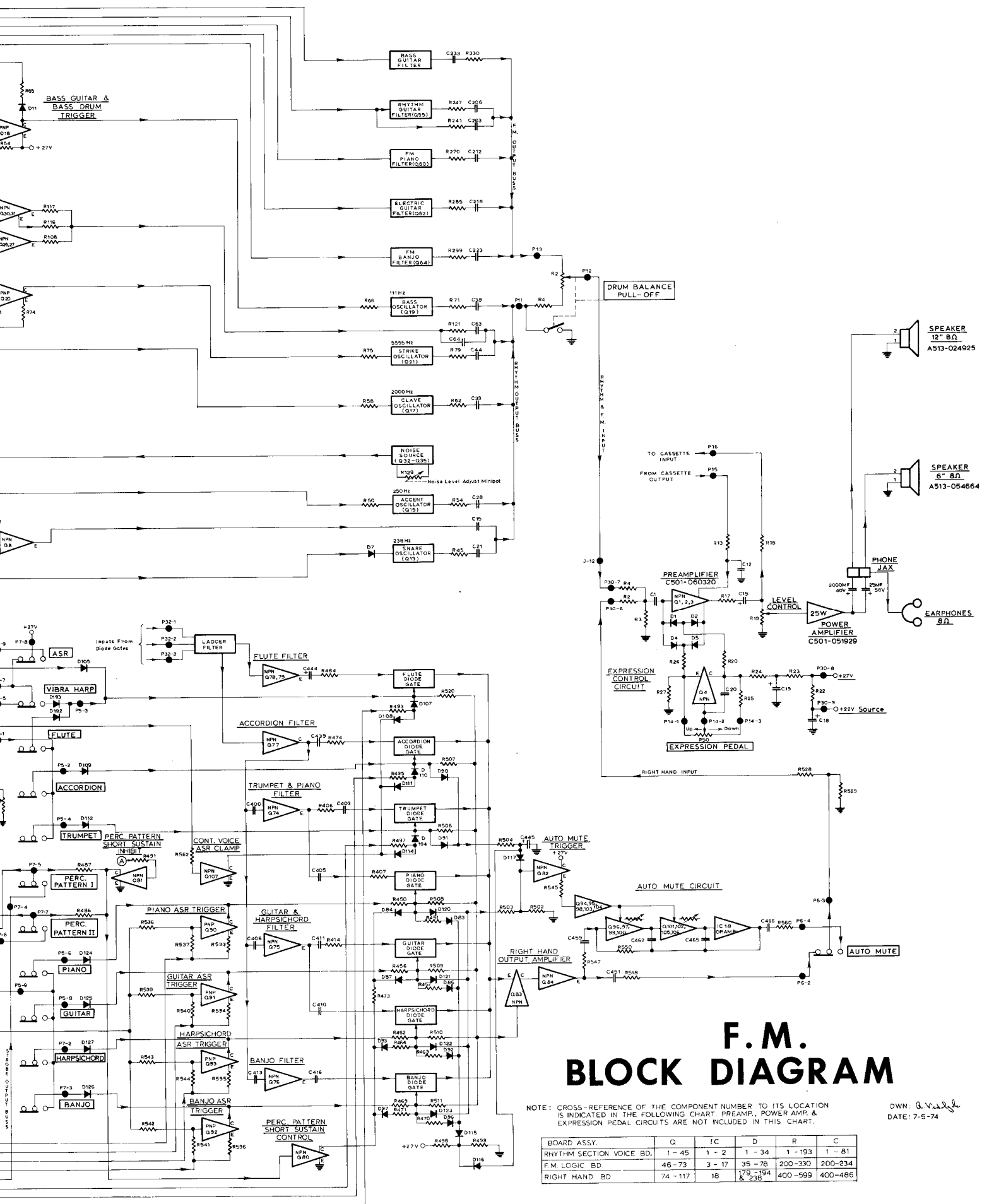

F.M. BLOCK DIAGRAM

NOTE: CROSS-REFERENCE OF THE COMPONENT NUMBER TO ITS LOCATION IS INDICATED IN THE FOLLOWING CHART. PREAMP., POWER AMP. & EXPRESSION PEDAL CIRCUITS ARE NOT INCLUDED IN THIS CHART.

DWN: B. V. [Signature]
DATE: 7-5-74

BOARD ASSY.	Q	IC	D	R	C
RHYTHM SECTION VOICE BD.	1 - 45	1 - 2	1 - 34	1 - 193	1 - 81
F.M. LOGIC BD.	46 - 73	3 - 17	35 - 78	200 - 330	200 - 234
RIGHT HAND BD.	74 - 117	18	178 - 194 & 236	400 - 599	400 - 486

FIGURE 13

LEAD
 Ord. No. R.N. 650
 Date / 18/ 174
RECORD OF CHANGE
 A) ADDED BKY/RED & BK/VEL
 WIRES - C.M. 15/938. D.D. 6-20-74

TYPICAL LATCHING SWITCH
 SHOWN IN NORMALLY OFF POSITION.

A1 B1 NORMALLY CLOSE
 A2 B2 COMMON
 A3 B3 NORMALLY OPEN

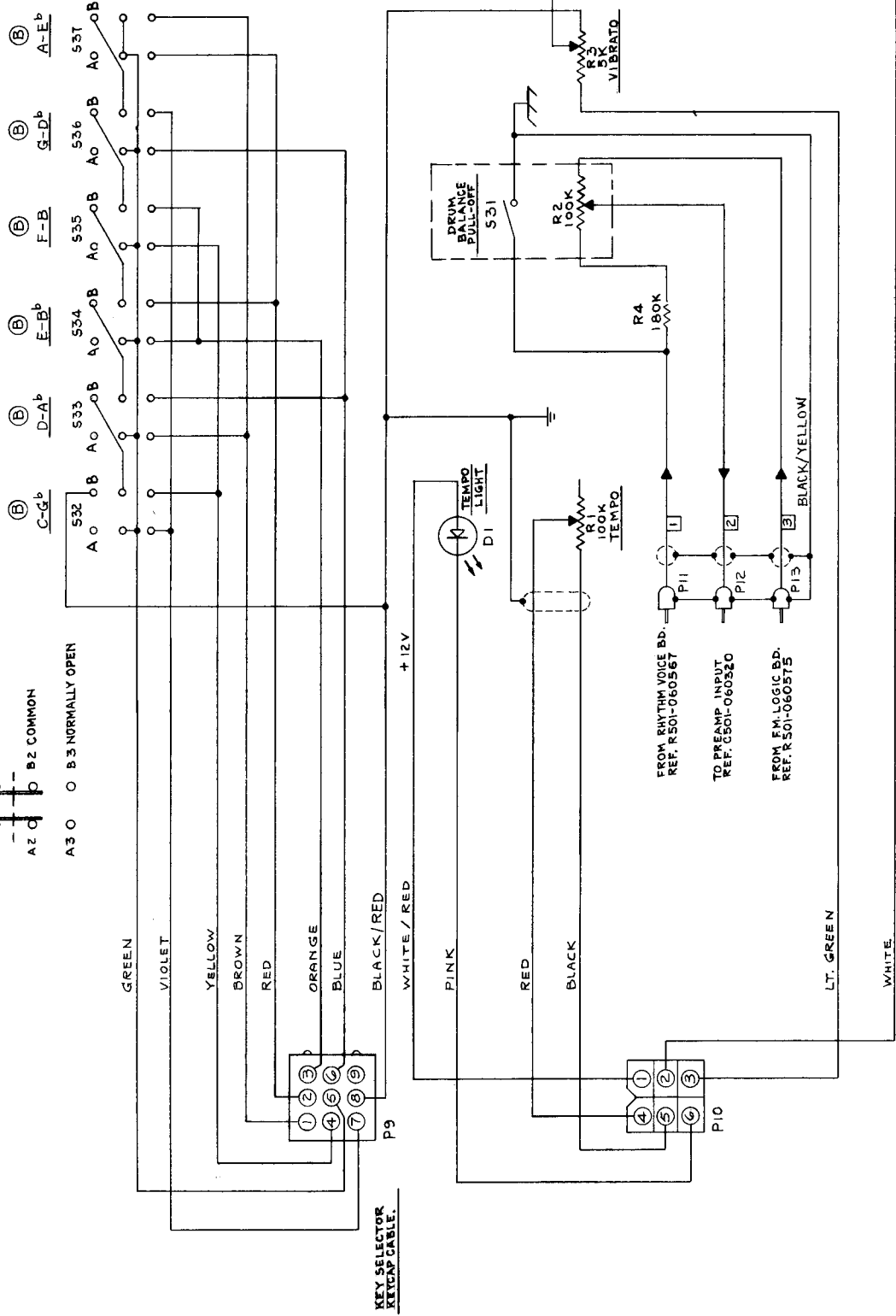

NOTES:
 1. (1), (2), (3) INDICATES BLUE PUSH BUTTON INSERT.
 2. TWO SEPARATE GROUNDS:
 ⊕ GENERAL GROUND.
 ⚡ SIGNAL GROUND.

DATE	11-1-73	ENR. ROBERTS	CHD. DMJ	APPR. B.L.	DES. E.P.T.	USED ON	UNR. SCALE	PART NAME	KEYCAP
CHK.	S	GR.	CON.	SAV.	SBL. 1BR 3 S.L.	MOD. 121	1	KEY SELECTOR	KEYCAP
DESCRIPTION	S							WIRING	DIAGRAM
COMPONENTS									
RESISTORS	R 4								
PLUGS	P 13								
SWITCHES	S 7								
DIODE (L.E.D.)	D 1								

UNLESS OTHERWISE SPECIFIED TOLERANCES ARE: RESISTORS ± 5% CAPACITORS ± 10% MECHANICAL ± .010" DIMENSIONS ± .005" UNLESS OTHERWISE SPECIFIED

BALDWIN PIANO & ORGAN CO.
 CINCINNATI, OHIO

501-060331 A

RHYTHM SECTION

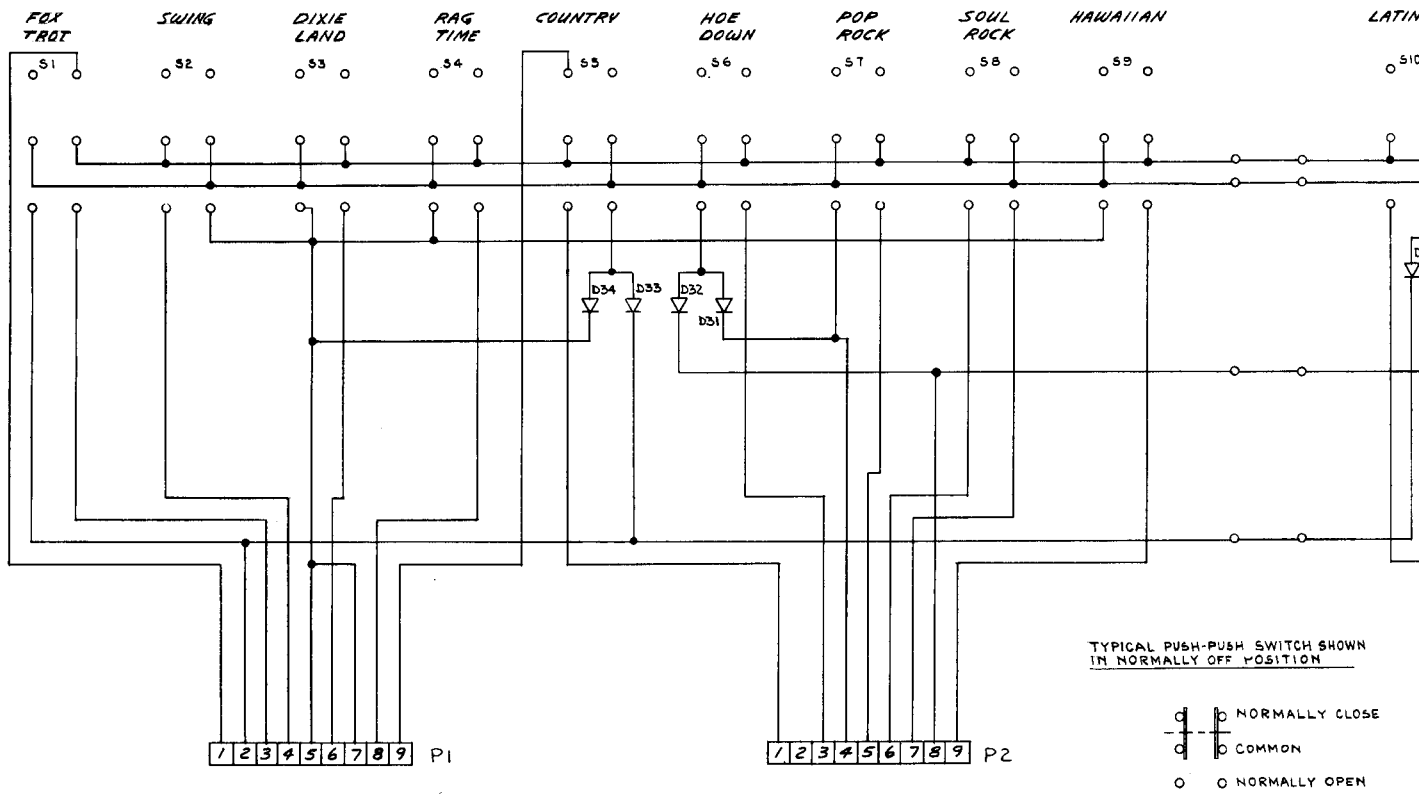

SOLOIST SECTION (REF. R501-060699)

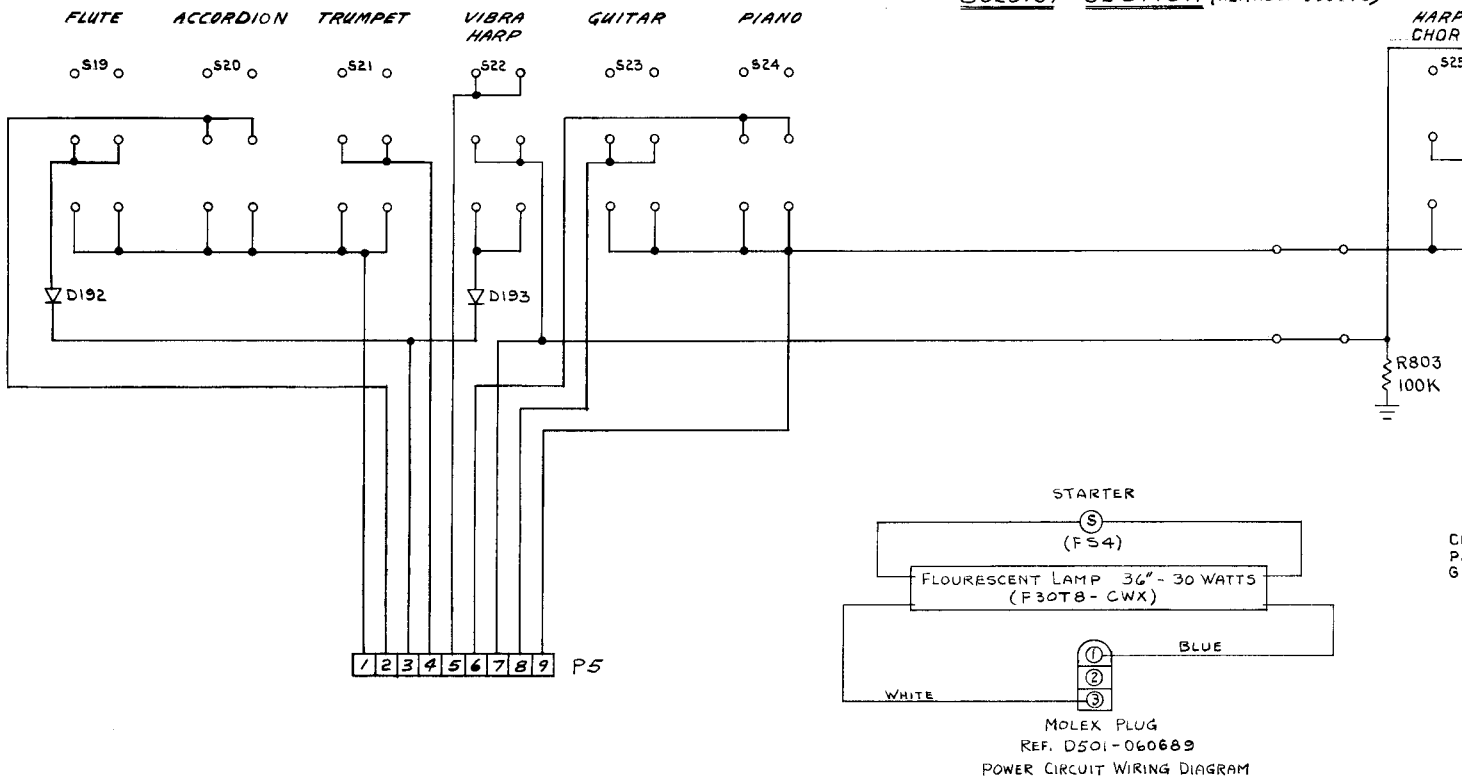

C
P
G

HM SECTION (REF. R501-060567)

RELEASED
 Ord. No. R.N. 650
 Date 1/15/74
 RECORD OF CHANGE
 (A) ADDED R803-100K.
 CN16.051 D.D. 10-2-74

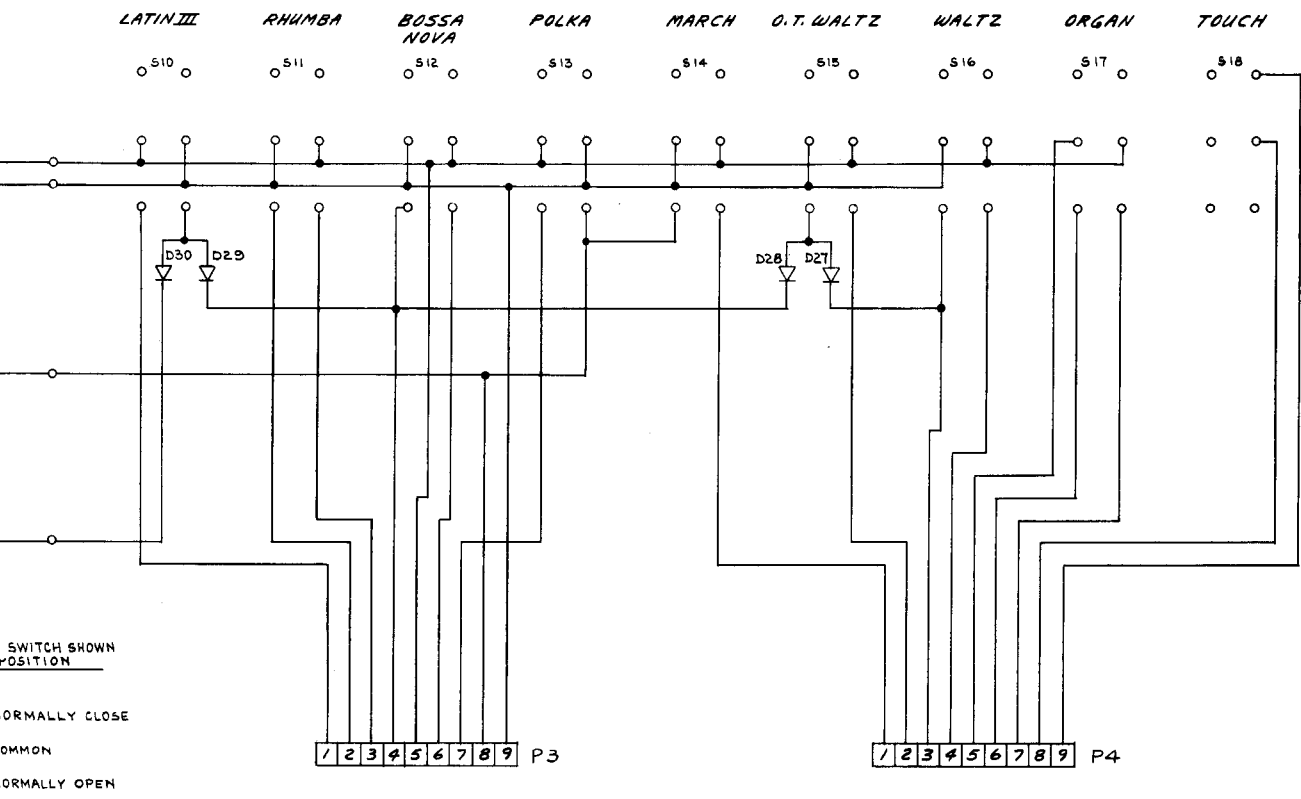

(1-060699)

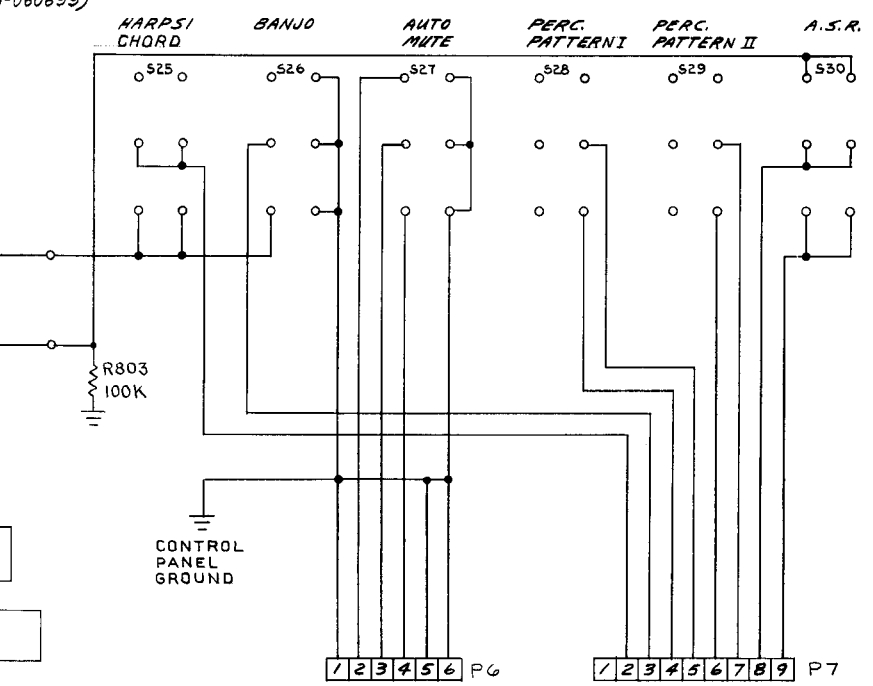

NOTES:
 1. ALL DISCONNECT SHOWN, REF. FUN MACHINE CABLE R508-060700.
 2. DIODE NUMBER PER REF. SCHEMATICS. R501-060567, R501-060699

DATE	DWN.	CHK'D.	APP'D.	DWN/SCALE	USED ON	PART NAME	
10-26-73	DUSTAUPE	AM	Rk		121	CONTROL PANEL WIRING DIA.	
PRINT	CIN.	GR.	COM.	FAY.	DEG.	E.P.T.	
DISTRIBUTION	S			SBL-1BR	SBL		
ALL DIMENSIONS AND SPECIFICATIONS ARE AND REMAIN THE PROPERTY OF THE BALDWIN PIANO & ORGAN CO. AND MUST BE RETURNED TO IT. ALL SPECIFICATIONS ARE CONFIDENTIAL AND ARE NOT TO BE DISCLOSED TO ANY PERSON OTHER THAN THOSE TO WHOM THEY ARE SENT. NO CHANGES, SPECIFICATIONS OR OTHER DATA BELONGING TO THE BALDWIN PIANO & ORGAN CO. WHICH MAY BE FURNISHED TO MANUFACTURERS OR OTHERS FOR ANY PURPOSE ARE TO BE REPRODUCED BY APPLICATION OR OTHERWISE IN ANY MANNER, INCLUDING THE FILING OF ANY OTHER PATENT OR APPLICATION OR CONVEYING ANY RIGHTS OR PERMISSION TO MANUFACTURE, USE OR SELL ANY PATENTED INVENTION THAT MAY IN ANY WAY BE RELATED THERETO.						NEXT ASSEMBLY	SUPERSEDES
UNLESS OTHERWISE SPECIFIED TOLERANCES ARE: DECIMAL ±.005 FRACTIONAL ±.015 ANGLE ±.1°						BALDWIN PIANO & ORGAN CO. CINCINNATI, OHIO	D 501-060267 A

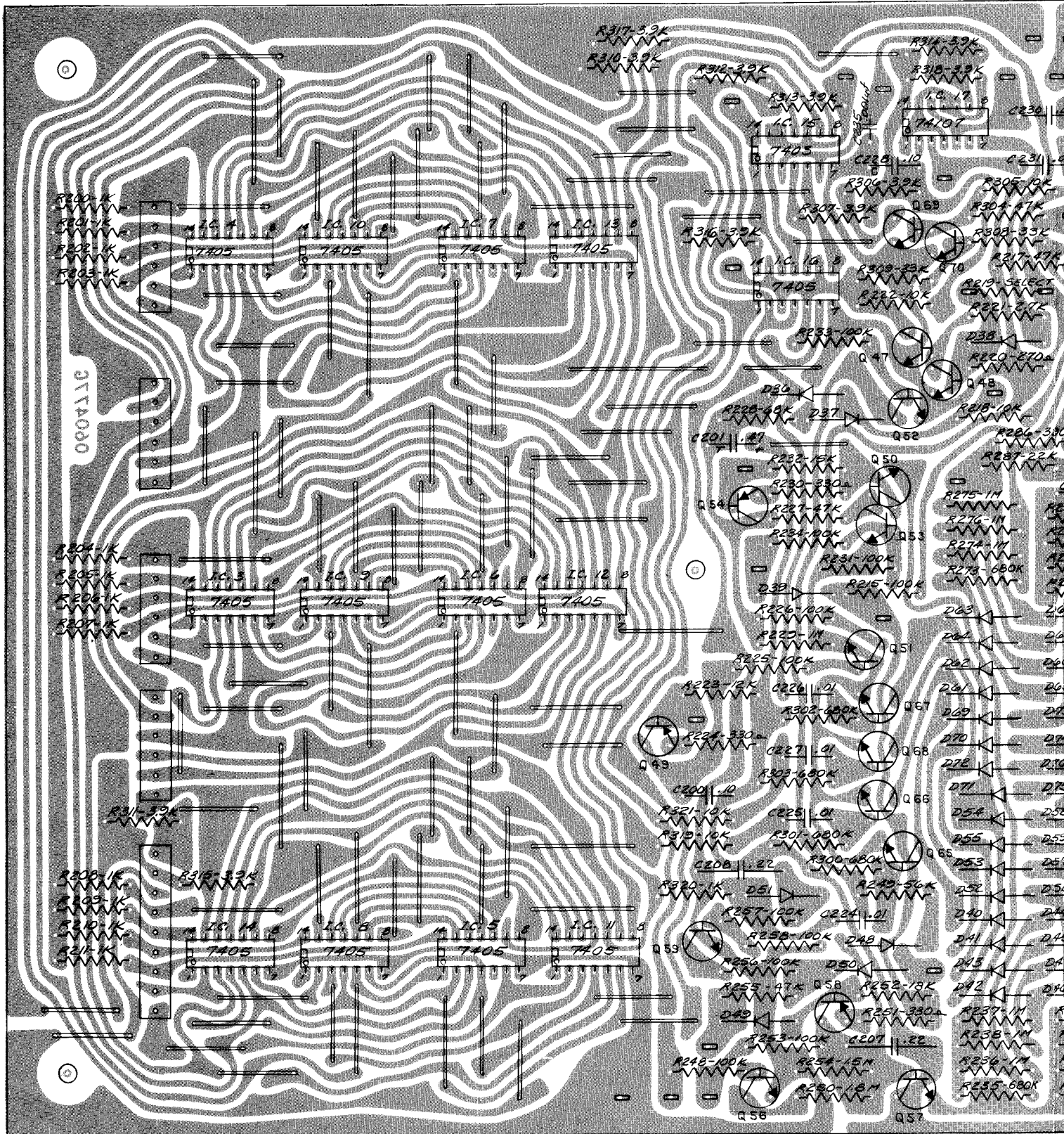

NOTES:

- 1) SELECT R219 PER S709 & S717. SELECTION RANGE 220Ω TO 10K.
- 2) REFERENCE SCHEMATIC- R501-060575 (12I) R501-061025 (127, 128F).
- 3) PIN WIRING DIAGRAM- C501-060480 (12I, 127) C501-061317 (128F).
- 4) FINAL ASSEMBLY MUST INCLUDE LABEL MARKED 500-060479 J

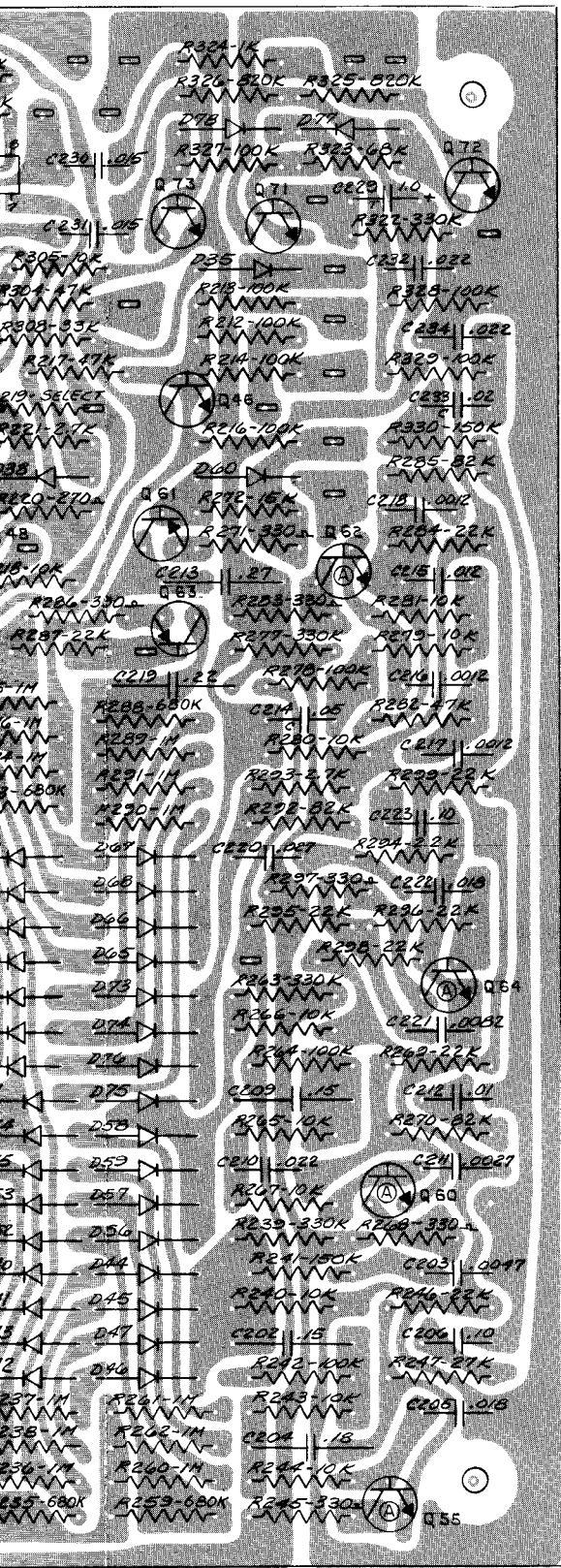

LEGEND:

'C' DENOTES CERAMIC CAPACITOR
'T' DENOTES TANTALUM CAPACITOR

RELEASED	
Ord. No.	R.N. G50
Date	1/23/74
RECORD OF CHANGE	
G REDRAW 2 TIMES SIZE 2/10/74 KMB NO C.M.	
F R235, R259, R273 & R288 WERE 1MΩ. C.N. 16, 121-11-21-74 J.C.	
E ADDED C235 - .001uf TO CORRECT SMOOTS TRIGGERING OF Panel Displays Per Customer K. BRADY 7-11-73	
H R252 WAS 12K. R255 WAS 100K. REVISED NOTE 4. C.N. 16, 408 B-12-75 W.R.M.	
I ALSO: REVISED NOTE 1. C.N. 16, 405 B-13-75 W.R.M.	
J ALL RESISTORS WERE 5239-1/2W 10% C.N. 14, 532 1-21-76 QML	

62	1	S250-183	RESISTOR 1/4W 5% 18K
61			
60	1	S205-102	CAPACITOR .001uf CER.
59	X	5134-4	SOLDER (IRON)
58	X	5184-3	SOLDER (DIP)
57	X	5137-4	BARE COPPER WIRE
56	1	A514-054489	JK FLIP FLOP TYPE 74107
55	1	A514-053464	QUAD 2 INPUT NAND GATE-7403
54	1	A507-059127	WAFER INTERCONNECT-9PIN
53	4	A507-059125	WAFER INTERCONNECT-6 PIN
52	13	A514-060021	HEX. INVERTER TYPE 7405
51			
50			
49	1	S244-35-105-2	CAPACITOR TANT. 1uf 35V
48	1	S244-35-474-1	TANT. 4uf 35V
47	1	S232-01-274	MYLAR .27uf
46	3	224	.22uf
45	1	184	.18uf
44	2	154	.15uf
43	3	104	.10uf
42	1	273	.027uf
41	3	223	.022uf
40	2	183	.018uf
39	2	153	.015uf
38	1	123	.012uf
37	5	103	.01uf
36	1	822	.0082uf
35	1	472	.0047uf
34	1	272	.0027uf
33	3	S232-01-122	MYLAR .0012uf
32	1	S218-104	CER. .1uf
31	1	S218-503	CER. .05uf
30	1	S205-203	CAPACITORS CER. .02uf
29	1	S239-185-10	RESISTOR 1/2W 10% 1.8M
28	1	S239-155-10	1/2W 10% 15M
27	13	S250-105	1/4W 5% 1M
26	2	824	820K
25	8	684	680K
24	4	334	330K
23	2	154	150K
22	21	104	100K
21	3	823	82K
20	2	683	68K
19	1	563	56K
18	5	473	47K
17	2	333	33K
16	1	273	27K
15	8	223	22K
14	2	153	15K
13	1	123	12K
12	14	103	10K
11	11	392	3.9K
10	2	272	2.7K
9	1	222	2.2K
8	14	S250-102	1/4W 5% 1.0K
7	9	S239-331-10	1/2W 10% 330Ω
6	1	S239-271-10	1/2W 10% 270Ω
5	1	S239-XXX-10	RESISTOR 1/2W 10% SELECT
4	44	A514-042791	DIODE-MED. VOLTAGE
3	23	A514-033338	TRANSISTOR-NPN
2	5	A514-044910	TRANSISTOR-PNP
1	1	C505-060478	F.M. LOGIC B'D RIVETED

DATE	9-10-74	DWN	BRADY	APPD.	Rdg.	DWN SCALE	USED ON	PART NAME
PRINT	CIN	GR.	CON.	FAY.	DEG.	E.P.T.	211, 27, 123	F.M. LOGIC B'D - ASS'Y.
DISTRIBUTION	FILE			BL. 1B	3 BL.		FINISH	BM 503-121-17 OR 4 IT.
<small>ALL DRAWINGS AND SPECIFICATIONS ARE AND REMAIN THE PROPERTY OF THE BALDWIN PIANO & ORGAN CO. AND MUST BE RETURNED TO IT. ALL SPECIFICATIONS ARE CONFIDENTIAL AND ARE NOT TO BE DISCLOSED TO ANY PERSON OTHER THAN THOSE TO WHOM THEY ARE SENT. NO DIMENSIONS, SPECIFICATIONS OR OTHER DATA BELONGING TO THE BALDWIN PIANO & ORGAN CO. WHICH MAY BE PURCHASED TO MANUFACTURE OR OTHERWISE FOR ANY PURPOSES ARE TO BE REPRODUCED BY REPLICATION OR OTHERWISE IN ANY MANNER, INCLUDING THE FILING OF ANY OTHER PAPER OR COPIATION OR COVERED BY PATENT RIGHTS OR PERMISSION TO MANUFACTURE, USE OR SELL ANY PATENTED INVENTION THAT MAY IN ANY WAY BE RELATED THEREIN.</small>								NEXT ASSEM. 500-060478 SUPERSEDES BALDWIN PIANO & ORGAN CO. CINCINNATI, OHIO
UNLESS OTHERWISE SPECIFIED TOLERANCES ARE: DECIMAL ± .005 FRACTIONAL ± .015 ANGLE ± .1°								D 500-060479 J

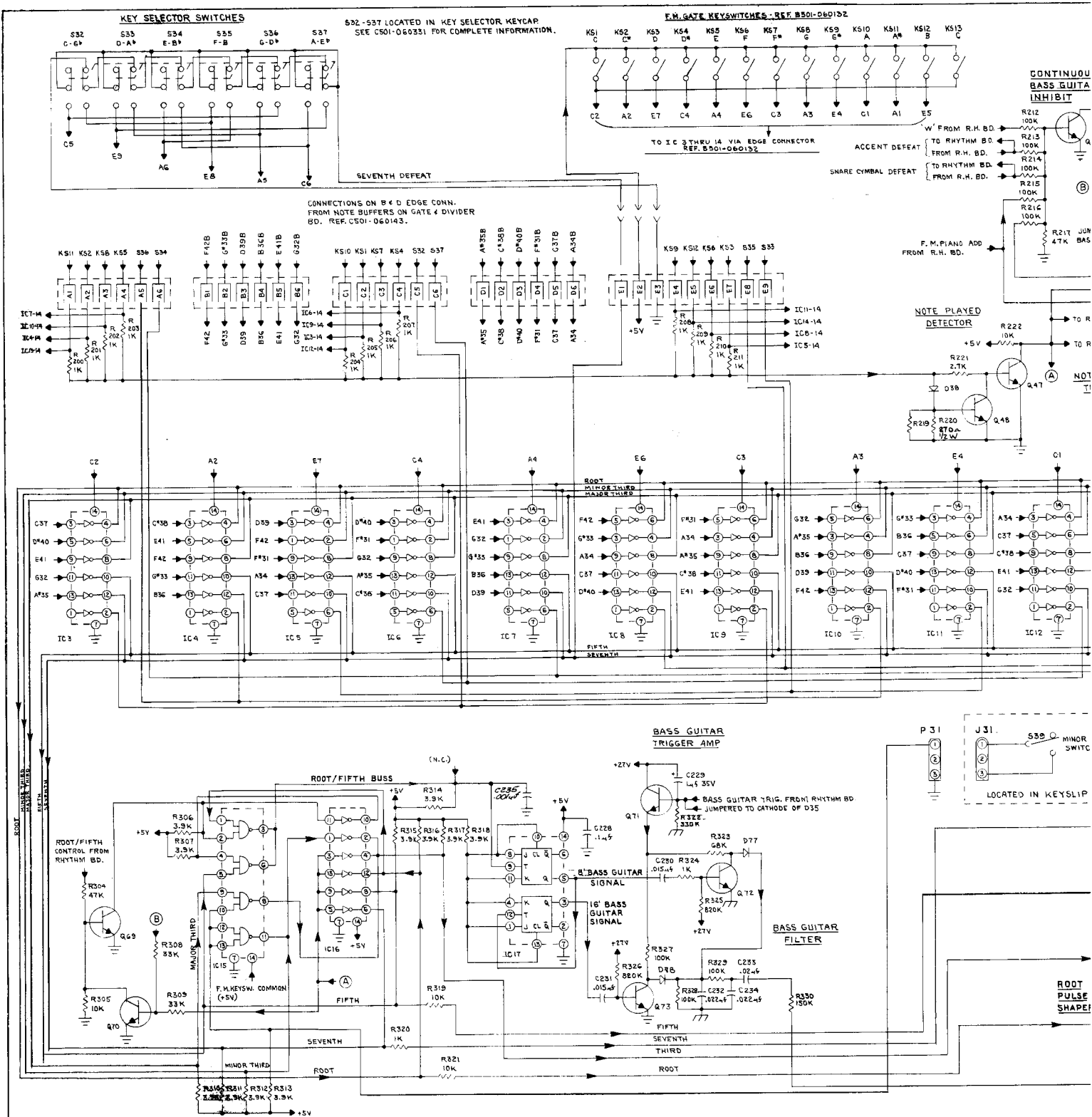

NOTES:

1. D.C. VOLTAGE MEASUREMENTS TAKEN WITH A VOLTMETER (20,000 OHMS PER VOLT OR HIGHER) FROM POINT INDICATED TO GROUND.
2. ALL RESISTORS ARE 1/4W 5% UNLESS OTHERWISE SPECIFIED.
3. SELECT NPN TRANSISTORS PER S429 - AS INDICATED.
4. SELECT R219 PER S709. SELECTION RANGE 220Ω TO 10K
5. IC 3 THRU 14 & 16: AS14-060021, HEX INVERTER TYPE 7405.
6. IC15: AS14-059464, QUAD 2 INPUT NAND TYPE 7403.
7. IC17: AS14-054489, DUAL JK FLIP FLOP TYPE 74107.

- B. TWO GROUND SYSTEMS DESIGNATED AS:**
- ⊕ GENERAL GROUND FOR SWITCHING CIRCUITS.
 - ⊕ PREAMP GROUND FOR SIGNAL CIRCUITS.

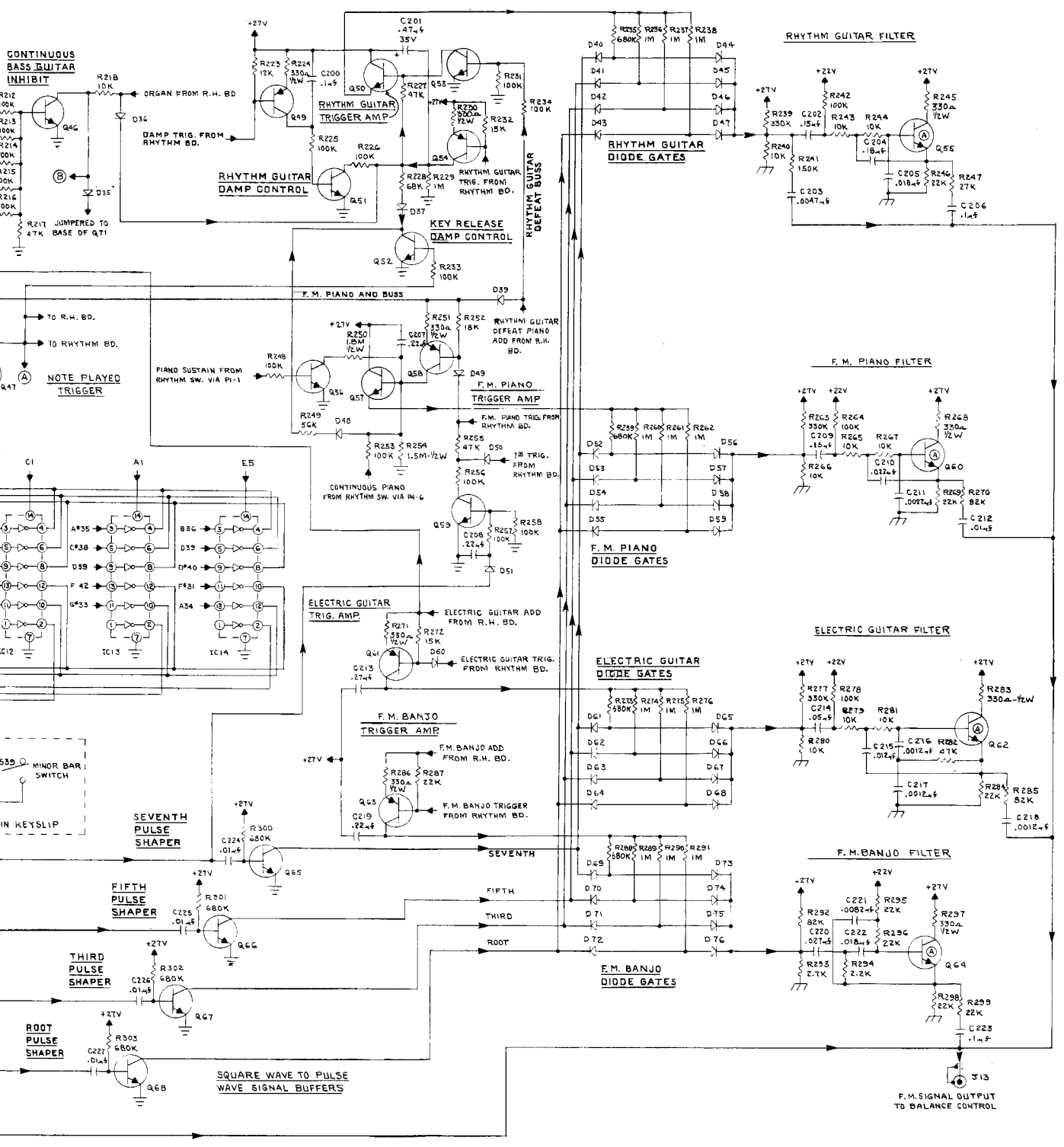

RECORD OF CHANGE

R220 WAS 220Ω.
C.N. 15, 155 D.D. 2-2-73
CHANGES TO THE LOW LEAD TIME
FUNCTION OF Q49 & R255
C.N. 15, 157 M.S. 2-25-73
REVISED PER TECH. SM
REQUEST. NO. C.N.
S-27-74 W.R.M.
D) R255, R259, R273 &
R288 WERE 1MΩ
C.N. 16, 121 - 11-20-74 J.C.
E) Added C236 - .001μf
to correct Sounding
regarding the F.M. Piano
Diode Gates. See C.N. 16, 96
& 1000 of 11-21-74
F) R288 WAS 1K. R255 WAS
100K. C.N. 16, 408
W.R.M.
G) R220, R224, R220, R24E
R250, R251, R254, R271, R28E
R286, R297, R268, REMAIN
1/2W. ALL OTHERS ARE 1/4W
C.N. 16, 552 1-29-76 D.E.B.

COMP. NO'S
R200 - R330
C200 - C235
Q46 - Q75
D35 - D78
IC3 - IC17

DATE 12-19-73	DRW. D. DIEHL	CHK. J. J.	APPD. B. L.	DRW. SCALE	USED ON ORGAN 121	PART NAME
DIFFERENTIAL	S	FAY.	DEO.	E. P. T.	REQ.	F.M. LOGIC BD. - SCHEMATIC
<small>ALL DIMENSIONS AND SPECIFICATIONS ARE UNLESS OTHERWISE SPECIFIED TO THE BALDWIN PIANO & ORGAN CO. AND MUST BE MAINTAINED TO THE CLOSEST POSSIBLE TOLERANCE. DIMENSIONS ARE TO CENTER UNLESS OTHERWISE SPECIFIED. DIMENSIONS TO CENTER UNLESS OTHERWISE SPECIFIED. DIMENSIONS TO CENTER UNLESS OTHERWISE SPECIFIED. DIMENSIONS TO CENTER UNLESS OTHERWISE SPECIFIED. UNLESS OTHERWISE SPECIFIED. DIMENSIONS TO CENTER UNLESS OTHERWISE SPECIFIED. DIMENSIONS TO CENTER UNLESS OTHERWISE SPECIFIED.</small>						F.M. LOGIC BD. - SCHEMATIC BALDWIN PIANO & ORGAN CO. CINCINNATI, OHIO

R 501-060575 G

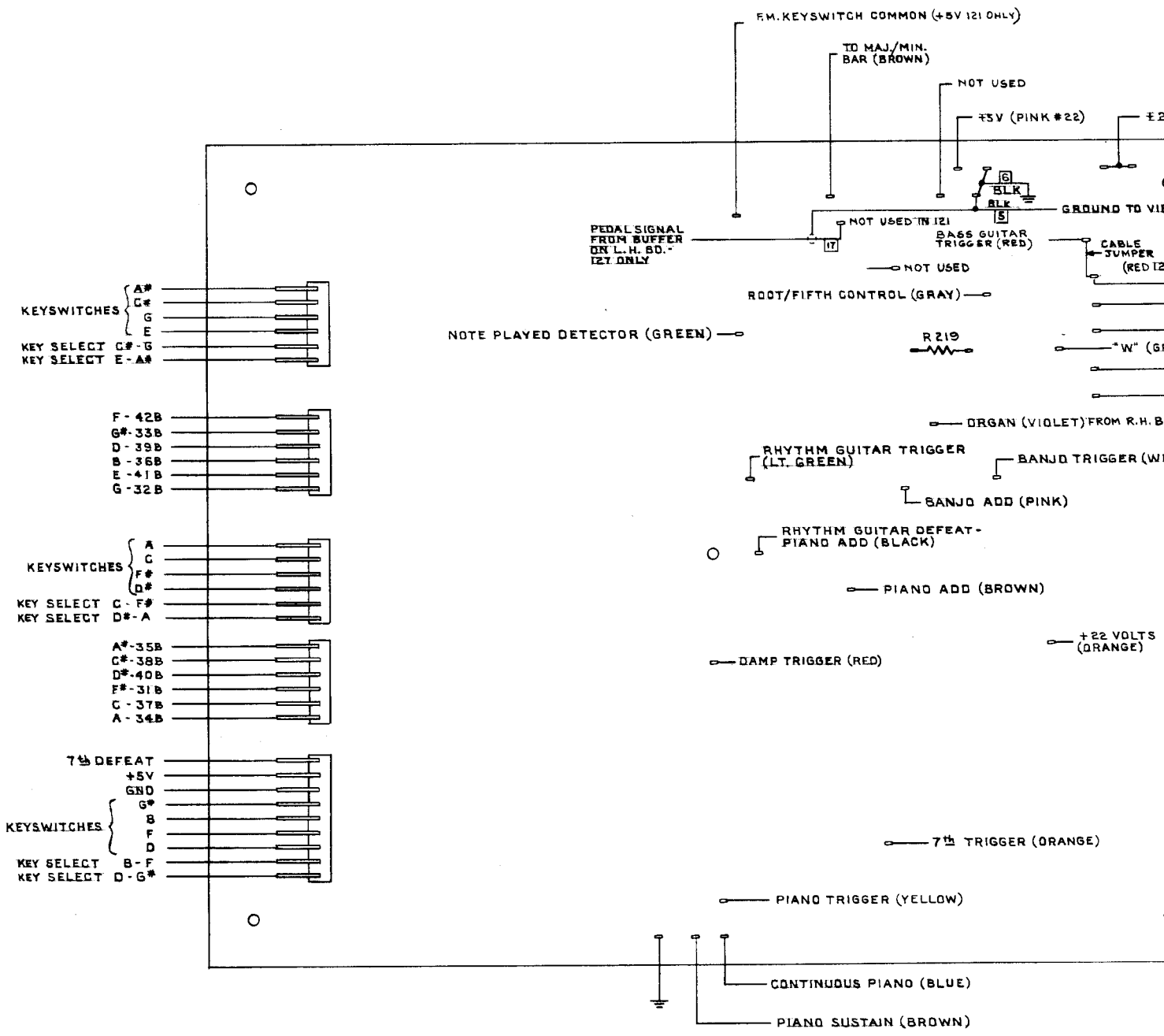

NOTES:
 1. REF. R501-0605T5 - F.M. LOGIC BOARD SCHEMATIC.

DATE	12-31-73	DWN.	W. R. MAYHEW
PRINT	CIN.	GR.	C
DISTRIBUTION	S		
<small>ALL DRAWINGS AND SPECIFICATIONS ARE AND REM/ RETURNED TO IT. ALL SPECIFICATIONS ARE CONFIDENTIAL TO WHOM THEY ARE SENT. NO DRAWINGS, SPECIFICATIONS OR OTHER INFORMATION IS TO BE FURNISHED TO MANUFACTURERS OR OTHERWISE AS IN ANY MANNER LICENSING THE HOLD OR PERMISSION TO MANUFACTURE, USE OR SELL AN UNLESS OTHERWISE SPECIFIED TOLERANCE</small>			

RELEASED

Ord. No. R. N. 650
Date 7/13/74

RECORD OF CHANGE

(A) REVISED TO INCLUDE
ORGAN IZ7. C. N. IS, B01
S-22-74 W.R.M.

F.M. KEYSWITCH COMMON (+5V I21 ONLY)

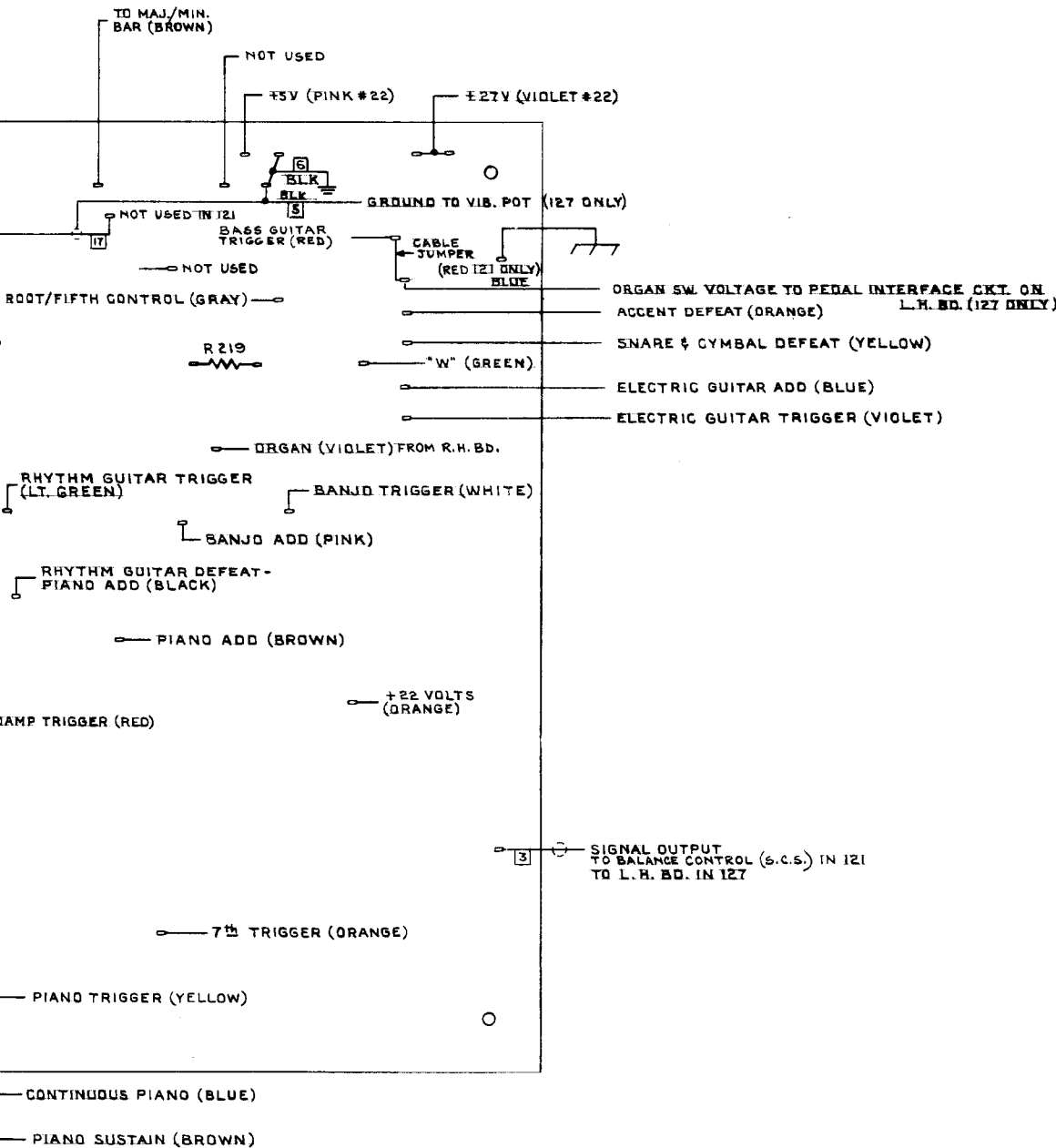

RD SCHEMATIC.

DATE 12-31-73	DWN. W. R. MAYHEW	CHD. DMJ	APPD. Rok	DWN. SCALE FULL	USED ON I21	PART NAME F.M. LOGIC BD. PIN WIRING DIAGRAM
PRINT CIN. GR. CON. FAY. DEG. E.P.T.	REG. ---	FINISH --- BM 503-121-17 GR. IT.				
DISTRIBUTION S	5BL-1BR		5BL		NEXT ASSEM. --- SUPERSEDES	
<small>ALL DRAWINGS AND SPECIFICATIONS ARE AND REMAIN THE PROPERTY OF THE BALDWIN PIANO & ORGAN CO. AND MUST BE RETURNED TO IT. ALL SPECIFICATIONS ARE CONFIDENTIAL AND ARE NOT TO BE DISCLOSED TO ANY PERSONS OTHER THAN THOSE TO WHOM THEY ARE SENT. NO DRAWINGS, SPECIFICATIONS OR OTHER DATA BELONGING TO THE BALDWIN PIANO & ORGAN CO. WHICH MAY BE FURNISHED TO MANUFACTURERS OR OTHERS FOR ANY PURPOSE ARE TO BE REGARDED BY IMPLICATION OR OTHERWISE AS IN ANY MANNER LICENSING THE HOLDER OF ANY OTHER PERSON OR CORPORATION OR CONVEYING ANY RIGHTS OR PERMISSION TO MANUFACTURE, USE OR SELL ANY PATENTED INVENTION THAT MAY IN ANY WAY BE RELATED THERETO.</small>						BALDWIN PIANO & ORGAN CO. CINCINNATI, OHIO
UNLESS OTHERWISE SPECIFIED TOLERANCES ARE: DECIMAL ± .005 FRACTIONAL ± .015 ANGLE ± 1/2°						C 501-060480 A

RHYTHM & FUN MACHINE VOICE PROGRAMMING
TO RHYTHM VOICE & F.M. LOGIC BOARDS

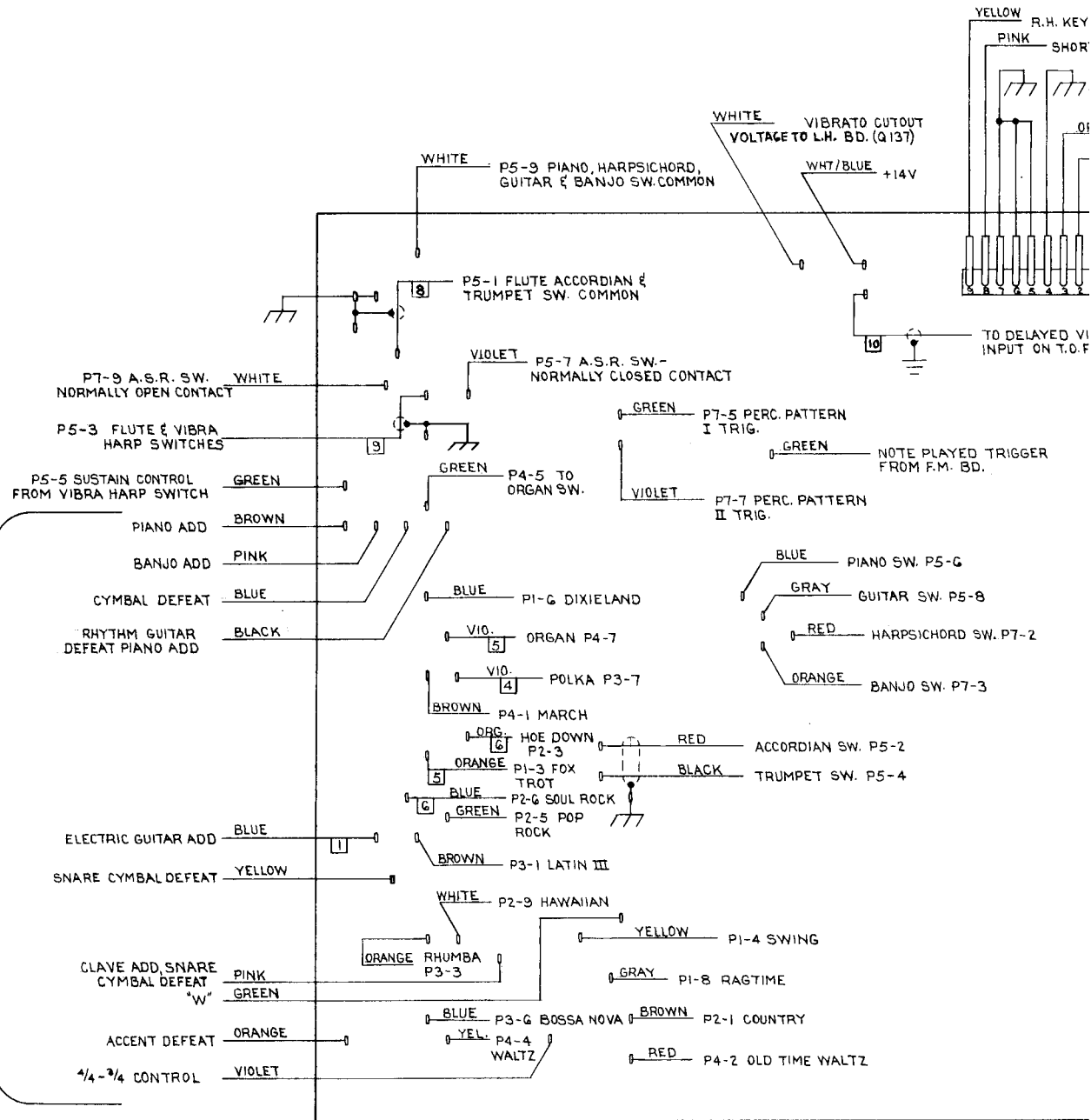

DATE 5-9-74

PRINT DISTRIBUTION

ALL DRAWINGS ARE RETURNED TO IT, A TO WHOM THEY ARE WHICH MAY BE FU OTHERWISE AS IN J OR PERMISSION TO

UNLESS OTH

RELEASED

Ord. No. R.N. 650
Date 1/28/74

RECORD OF CHANGE

② REDRAWN & REVISED
TO CONFORM WITH CIRCUIT
LAYOUT CHANGE.
C.N.15,8G7 D.L.L. 5-9-74

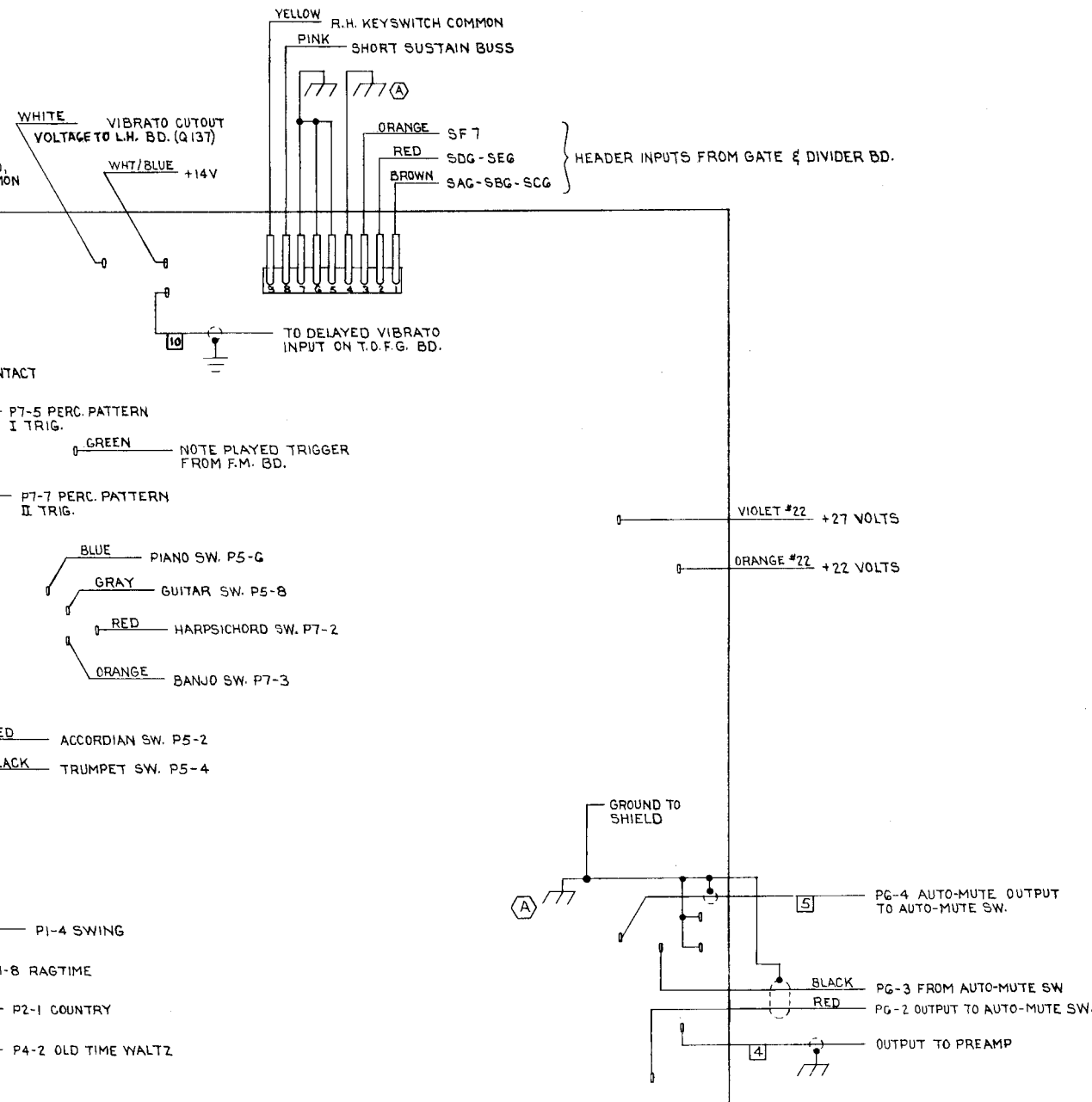

DATE	5-9-74	DWN.	D. Zanhan	CHKD.	5-10-74	APP'D.	DM	DWN. SCALE	FULL	USED ON	121	PART NAME	RIGHT HAND BOARD PIN WIRING DIAGRAM	
PRINT	CIN.	GR.	CON	FAY.	DEQ.	E. P. T.		REQ.	1	FINISH	BM 503-121-17	GR. NOTE	IT.	
<small>ALL DRAWINGS AND SPECIFICATIONS ARE AND REMAIN THE PROPERTY OF THE BALDWIN PIANO & ORGAN CO. AND MUST BE RETURNED TO IT. ALL SPECIFICATIONS ARE CONFIDENTIAL AND ARE NOT TO BE DISCLOSED TO ANY PERSONS OTHER THAN THOSE TO WHOM THEY ARE SENT. NO DRAWINGS, SPECIFICATIONS OR OTHER DATA BELONGING TO THE BALDWIN PIANO & ORGAN CO. WHICH MAY BE FURNISHED TO MANUFACTURERS OR OTHERS FOR ANY PURPOSE ARE TO BE REGARDED BY IMPLICATION OR OTHERWISE AS IN ANY MANNER LICENSING THE HOLDER OR ANY OTHER PERSON OR CORPORATION OR CONVEYING ANY RIGHTS OR PERMISSION TO MANUFACTURE, USE OR SELL ANY PATENTED INVENTION THAT MAY IN ANY WAY BE RELATED THERETO.</small>											NEXT ASSEM.	SUPERSEDES	REV.	
<small>UNLESS OTHERWISE SPECIFIED TOLERANCES ARE: DECIMAL ± .005 FRACTIONAL ± .015 ANGLE ± 1/8"</small>											BALDWIN PIANO & ORGAN CO. CINCINNATI, OHIO	C	501-060664	B

NOTE:
 FUNCTIONS MARKED (RM.)
 VOICE BD. REF. RS01-06
 FUNCTIONS MARKED (FM.)
 LOGIC BD. REF. RS01-06

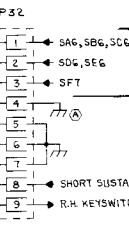
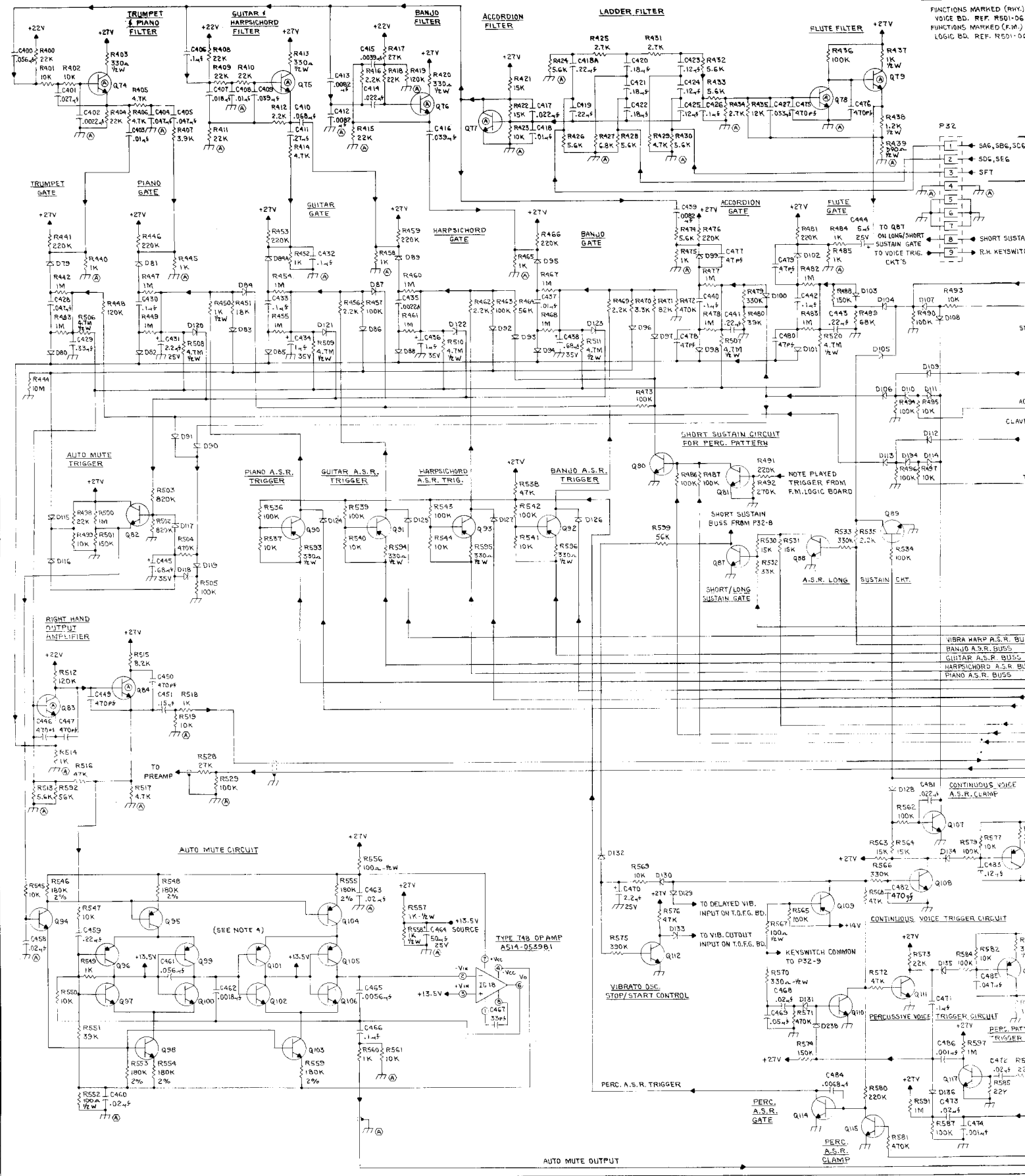

SHORT SUSTAIN CIRCUIT FOR PERC. PATTERN

NOTE PLAYED TRIGGER FROM F.M. LOGIC BOARD

SHORT SUSTAIN BUSS FROM P32-B

SHORT/LONG SUSTAIN GATE

A.S.R. LONG

SUSTAIN CKT.

VIBRA HARP A.S.R. BU
 BANJO A.S.R. BUSS
 GUITAR A.S.R. BUSS
 HARPSICHORD A.S.R. BU
 PIANO A.S.R. BUSS

CONTINUOUS VOICE A.S.R. CLAMP

CONTINUOUS VOICE TRIGGER CIRCUIT

PERCUSSIVE VOICE TRIGGER

PERC. A.S.R. TRIGGER

PERC. A.S.R. GATE

PERC. A.S.R. CLAMP

AUTO MUTE OUTPUT

TYPE 148 OP AMP
 AS14-0559B1

(SEE NOTE 4)

AUTO MUTE CIRCUIT

RIGHT HAND OUTPUT AMPLIFIER

AUTO MUTE TRIGGER

TRUMPET GATE

PIANO GATE

GUITAR & HARPSICHORD FILTER

TRUMPET & PIANO FILTER

ACCORDION FILTER

LADDER FILTER

FLUTE FILTER

BANJO FILTER

HARPSICHORD GATE

GUITAR GATE

BANJO GATE

ACCORDION GATE

FLUTE GATE

TRUMPET GATE

PIANO GATE

TRUMPET & PIANO FILTER

GUITAR & HARPSICHORD FILTER

BANJO FILTER

ACCORDION FILTER

LADDER FILTER

FLUTE FILTER

TRUMPET & PIANO FILTER

GUITAR & HARPSICHORD FILTER

BANJO FILTER

ACCORDION FILTER

LADDER FILTER

FLUTE FILTER

TRUMPET & PIANO FILTER

GUITAR & HARPSICHORD FILTER

BANJO FILTER

ACCORDION FILTER

LADDER FILTER

FLUTE FILTER

TRUMPET & PIANO FILTER

GUITAR & HARPSICHORD FILTER

BANJO FILTER

ACCORDION FILTER

LADDER FILTER

FLUTE FILTER

TRUMPET & PIANO FILTER

GUITAR & HARPSICHORD FILTER

BANJO FILTER

ACCORDION FILTER

LADDER FILTER

FLUTE FILTER

TRUMPET & PIANO FILTER

GUITAR & HARPSICHORD FILTER

BANJO FILTER

ACCORDION FILTER

LADDER FILTER

FLUTE FILTER

TRUMPET & PIANO FILTER

GUITAR & HARPSICHORD FILTER

BANJO FILTER

ACCORDION FILTER

LADDER FILTER

FLUTE FILTER

TRUMPET & PIANO FILTER

GUITAR & HARPSICHORD FILTER

BANJO FILTER

ACCORDION FILTER

LADDER FILTER

FLUTE FILTER

TRUMPET & PIANO FILTER

GUITAR & HARPSICHORD FILTER

BANJO FILTER

ACCORDION FILTER

LADDER FILTER

FLUTE FILTER

TRUMPET & PIANO FILTER

GUITAR & HARPSICHORD FILTER

BANJO FILTER

ACCORDION FILTER

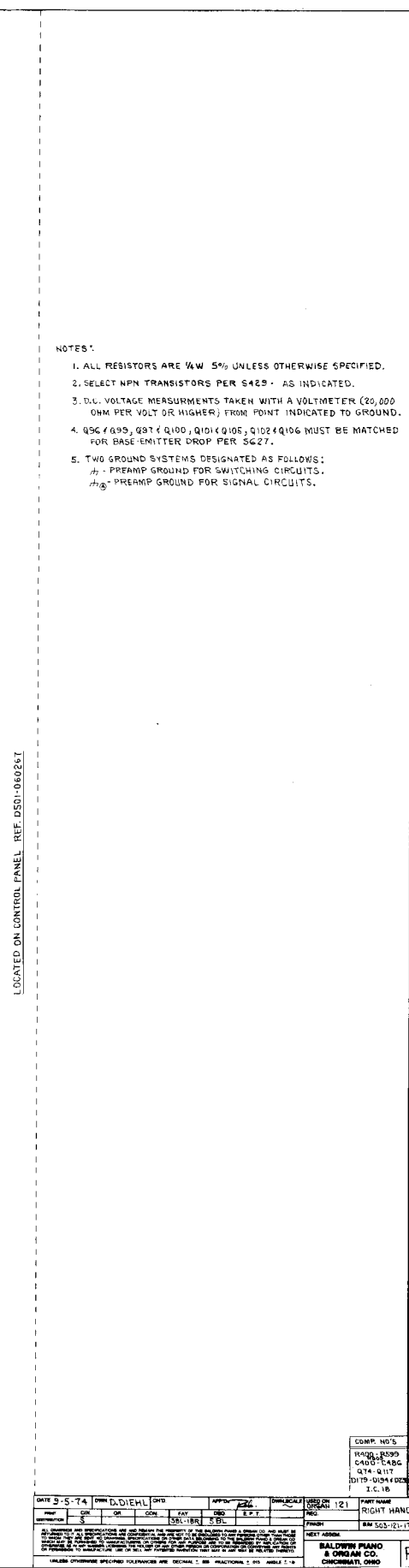
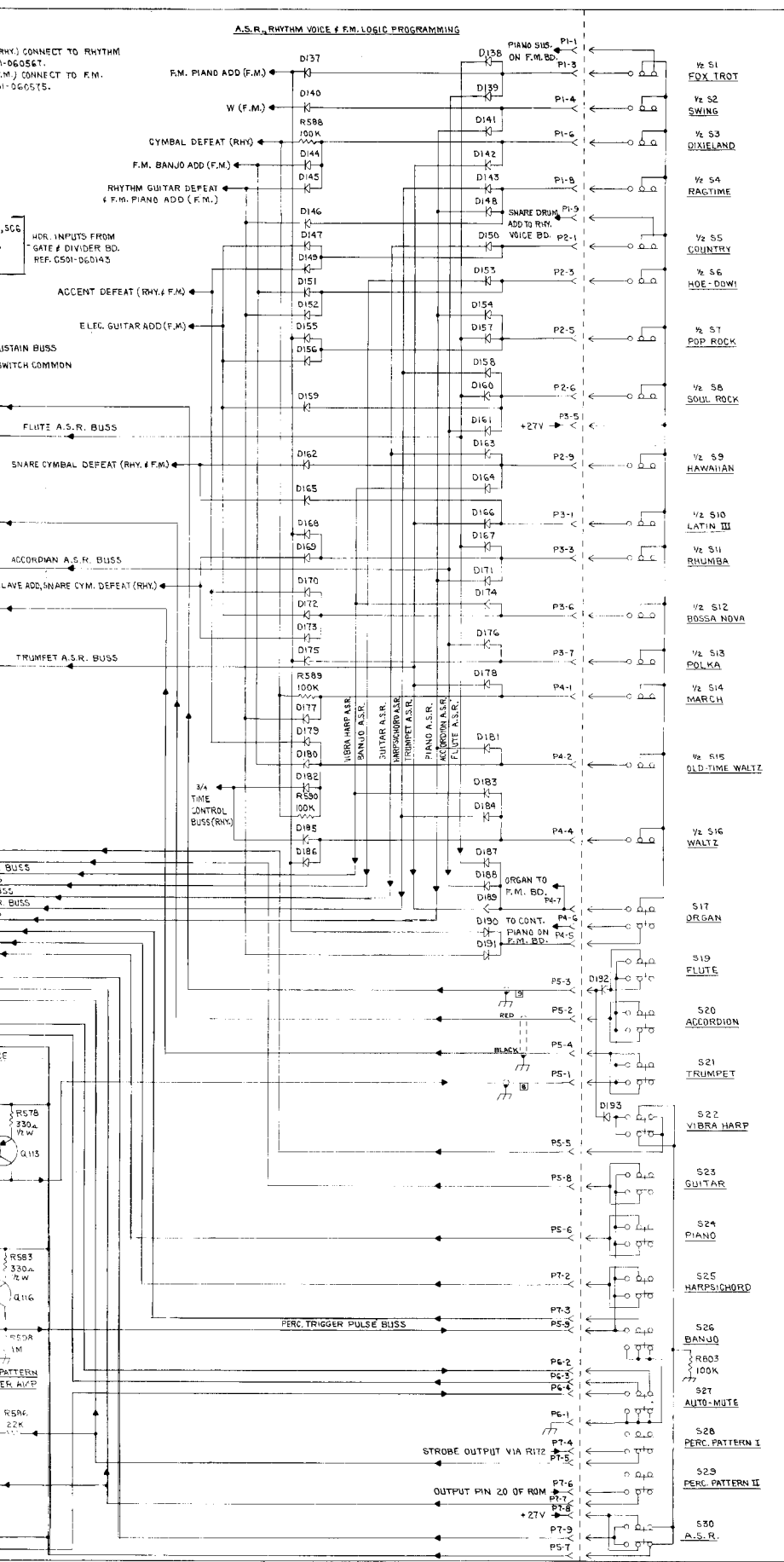

MILWAUKEE	
Out. No.	RM 650
Date	1/31/74
RECORD OF CHANGE	
(A) R441, R442, R443, R444, R445, R446, R447, R448, R449, R450, R451, R452, R453, R454, R455, R456, R457, R458, R459, R460, R461, R462, R463, R464, R465, R466, R467, R468, R469, R470, R471, R472, R473, R474, R475, R476, R477, R478, R479, R480, R481, R482, R483, R484, R485, R486, R487, R488, R489, R490, R491, R492, R493, R494, R495, R496, R497, R498, R499, R500, R501, R502, R503, R504, R505, R506, R507, R508, R509, R510, R511, R512, R513, R514, R515, R516, R517, R518, R519, R520, R521, R522, R523, R524, R525, R526, R527, R528, R529, R530, R531, R532, R533, R534, R535, R536, R537, R538, R539, R540, R541, R542, R543, R544, R545, R546, R547, R548, R549, R550, R551, R552, R553, R554, R555, R556, R557, R558, R559, R560, R561, R562, R563, R564, R565, R566, R567, R568, R569, R570, R571, R572, R573, R574, R575, R576, R577, R578, R579, R580, R581, R582, R583, R584, R585, R586, R587, R588, R589, R590, R591, R592, R593, R594, R595, R596, R597, R598, R599, R600, R601, R602, R603, R604, R605, R606, R607, R608, R609, R610, R611, R612, R613, R614, R615, R616, R617, R618, R619, R620, R621, R622, R623, R624, R625, R626, R627, R628, R629, R630, R631, R632, R633, R634, R635, R636, R637, R638, R639, R640, R641, R642, R643, R644, R645, R646, R647, R648, R649, R650, R651, R652, R653, R654, R655, R656, R657, R658, R659, R660, R661, R662, R663, R664, R665, R666, R667, R668, R669, R670, R671, R672, R673, R674, R675, R676, R677, R678, R679, R680, R681, R682, R683, R684, R685, R686, R687, R688, R689, R690, R691, R692, R693, R694, R695, R696, R697, R698, R699, R700, R701, R702, R703, R704, R705, R706, R707, R708, R709, R710, R711, R712, R713, R714, R715, R716, R717, R718, R719, R720, R721, R722, R723, R724, R725, R726, R727, R728, R729, R730, R731, R732, R733, R734, R735, R736, R737, R738, R739, R740, R741, R742, R743, R744, R745, R746, R747, R748, R749, R750, R751, R752, R753, R754, R755, R756, R757, R758, R759, R760, R761, R762, R763, R764, R765, R766, R767, R768, R769, R770, R771, R772, R773, R774, R775, R776, R777, R778, R779, R780, R781, R782, R783, R784, R785, R786, R787, R788, R789, R790, R791, R792, R793, R794, R795, R796, R797, R798, R799, R800, R801, R802, R803, R804, R805, R806, R807, R808, R809, R810, R811, R812, R813, R814, R815, R816, R817, R818, R819, R820, R821, R822, R823, R824, R825, R826, R827, R828, R829, R830, R831, R832, R833, R834, R835, R836, R837, R838, R839, R840, R841, R842, R843, R844, R845, R846, R847, R848, R849, R850, R851, R852, R853, R854, R855, R856, R857, R858, R859, R860, R861, R862, R863, R864, R865, R866, R867, R868, R869, R870, R871, R872, R873, R874, R875, R876, R877, R878, R879, R880, R881, R882, R883, R884, R885, R886, R887, R888, R889, R890, R891, R892, R893, R894, R895, R896, R897, R898, R899, R900, R901, R902, R903, R904, R905, R906, R907, R908, R909, R910, R911, R912, R913, R914, R915, R916, R917, R918, R919, R920, R921, R922, R923, R924, R925, R926, R927, R928, R929, R930, R931, R932, R933, R934, R935, R936, R937, R938, R939, R940, R941, R942, R943, R944, R945, R946, R947, R948, R949, R950, R951, R952, R953, R954, R955, R956, R957, R958, R959, R960, R961, R962, R963, R964, R965, R966, R967, R968, R969, R970, R971, R972, R973, R974, R975, R976, R977, R978, R979, R980, R981, R982, R983, R984, R985, R986, R987, R988, R989, R990, R991, R992, R993, R994, R995, R996, R997, R998, R999, R1000.	
NOTES: 1. ALL RESISTORS ARE 1/4W 5% UNLESS OTHERWISE SPECIFIED. 2. SELECT NPN TRANSISTORS PER S423 - AS INDICATED. 3. D.C. VOLTAGE MEASUREMENTS TAKEN WITH A VOLTMETER (20,000 OHM PER VOLT OR HIGHER) FROM POINT INDICATED TO GROUND. 4. Q56 & Q59, Q97 & Q100, Q101, Q105, Q102 & Q106 MUST BE MATCHED FOR BASE-EMITTER DROP PER S627. 5. TWO GROUND SYSTEMS DESIGNATED AS FOLLOWS: - PREAMP GROUND FOR SWITCHING CIRCUITS. - PREAMP GROUND FOR SIGNAL CIRCUITS.	
COMP. NO'S R441, R442, R443, R444, R445, R446, R447, R448, R449, R450, R451, R452, R453, R454, R455, R456, R457, R458, R459, R460, R461, R462, R463, R464, R465, R466, R467, R468, R469, R470, R471, R472, R473, R474, R475, R476, R477, R478, R479, R480, R481, R482, R483, R484, R485, R486, R487, R488, R489, R490, R491, R492, R493, R494, R495, R496, R497, R498, R499, R500, R501, R502, R503, R504, R505, R506, R507, R508, R509, R510, R511, R512, R513, R514, R515, R516, R517, R518, R519, R520, R521, R522, R523, R524, R525, R526, R527, R528, R529, R530, R531, R532, R533, R534, R535, R536, R537, R538, R539, R540, R541, R542, R543, R544, R545, R546, R547, R548, R549, R550, R551, R552, R553, R554, R555, R556, R557, R558, R559, R560, R561, R562, R563, R564, R565, R566, R567, R568, R569, R570, R571, R572, R573, R574, R575, R576, R577, R578, R579, R580, R581, R582, R583, R584, R585, R586, R587, R588, R589, R590, R591, R592, R593, R594, R595, R596, R597, R598, R599, R600, R601, R602, R603, R604, R605, R606, R607, R608, R609, R610, R611, R612, R613, R614, R615, R616, R617, R618, R619, R620, R621, R622, R623, R624, R625, R626, R627, R628, R629, R630, R631, R632, R633, R634, R635, R636, R637, R638, R639, R640, R641, R642, R643, R644, R645, R646, R647, R648, R649, R650, R651, R652, R653, R654, R655, R656, R657, R658, R659, R660, R661, R662, R663, R664, R665, R666, R667, R668, R669, R670, R671, R672, R673, R674, R675, R676, R677, R678, R679, R680, R681, R682, R683, R684, R685, R686, R687, R688, R689, R690, R691, R692, R693, R694, R695, R696, R697, R698, R699, R700, R701, R702, R703, R704, R705, R706, R707, R708, R709, R710, R711, R712, R713, R714, R715, R716, R717, R718, R719, R720, R721, R722, R723, R724, R725, R726, R727, R728, R729, R730, R731, R732, R733, R734, R735, R736, R737, R738, R739, R740, R741, R742, R743, R744, R745, R746, R747, R748, R749, R750, R751, R752, R753, R754, R755, R756, R757, R758, R759, R760, R761, R762, R763, R764, R765, R766, R767, R768, R769, R770, R771, R772, R773, R774, R775, R776, R777, R778, R779, R780, R781, R782, R783, R784, R785, R786, R787, R788, R789, R790, R791, R792, R793, R794, R795, R796, R797, R798, R799, R800, R801, R802, R803, R804, R805, R806, R807, R808, R809, R810, R811, R812, R813, R814, R815, R816, R817, R818, R819, R820, R821, R822, R823, R824, R825, R826, R827, R828, R829, R830, R831, R832, R833, R834, R835, R836, R837, R838, R839, R840, R841, R842, R843, R844, R845, R846, R847, R848, R849, R850, R851, R852, R853, R854, R855, R856, R857, R858, R859, R860, R861, R862, R863, R864, R865, R866, R867, R868, R869, R870, R871, R872, R873, R874, R875, R876, R877, R878, R879, R880, R881, R882, R883, R884, R885, R886, R887, R888, R889, R890, R891, R892, R893, R894, R895, R896, R897, R898, R899, R900, R901, R902, R903, R904, R905, R906, R907, R908, R909, R910, R911, R912, R913, R914, R915, R916, R917, R918, R919, R920, R921, R922, R923, R924, R925, R926, R927, R928, R929, R930, R931, R932, R933, R934, R935, R936, R937, R938, R939, R940, R941, R942, R943, R944, R945, R946, R947, R948, R949, R950, R951, R952, R953, R954, R955, R956, R957, R958, R959, R960, R961, R962, R963, R964, R965, R966, R967, R968, R969, R970, R971, R972, R973, R974, R975, R976, R977, R978, R979, R980, R981, R982, R983, R984, R985, R986, R987, R988, R989, R990, R991, R992, R993, R994, R995, R996, R997, R998, R999, R1000.	
DATE 3-5-74 DESIGNED BY D. DIEHL CHECKED BY J. J. BIL APPROVED BY J. J. BIL PART NAME RIGHT HAND VOICE BD. SCHEMATIC PART NO. RM 503-01-17 REV. 1 BALDWIN PIANO & ORGAN CO. CHICAGO, ILL. 60611 R 501-060699 E	



- NOTES: (SELECT NPN TRANSISTORS Q74, Q75, Q76, Q77, Q78, Q79, Q83, Q84 PER S429-A)
- 1) Q96 & Q99 - Q97 & Q100 - Q101 & Q105 - Q106 & Q102 ARE MATCHED FOR BASE EMITTER DR
 - 2) ALL DIODES ARE MEDIUM VOLTAGE 1N4148-1N4149 (1N7A)
 - 3) REFERENCE SCHEMATIC - R501-060699 (12I) R501-061056 (127, 128F) R501-061414 (128R)
 - 4) PIN WIRING DIAGRAM - C501-060664 (12I) - C501-061113 (127, 128F) C501-061451 (128R)

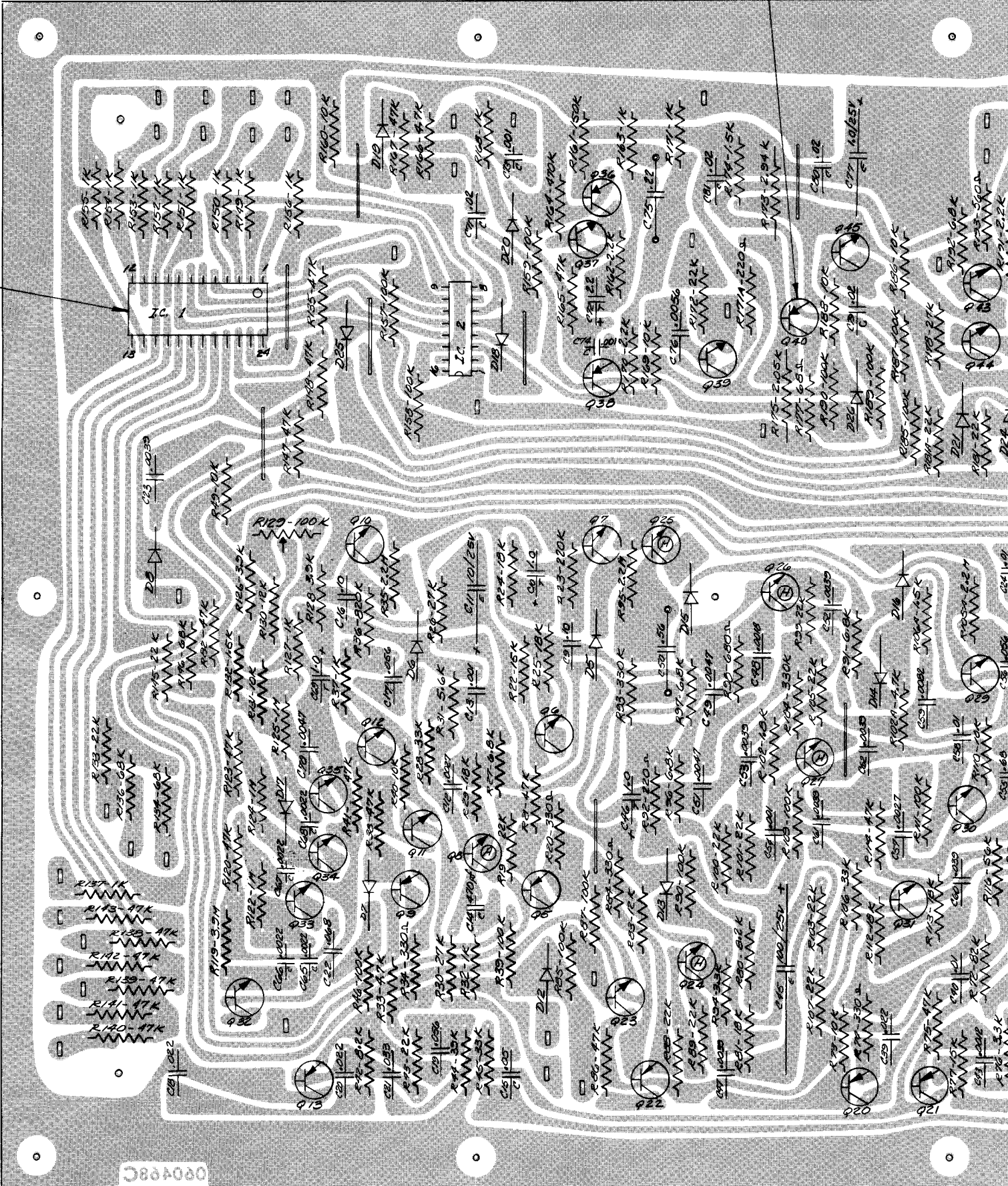

LEGEND: "C" DENOTES CERAMIC CAPACITOR
 "T" DENOTES TANTALUM CAPACITOR
 "E" DENOTES ELECTROLYTIC CAPACITOR

000489C

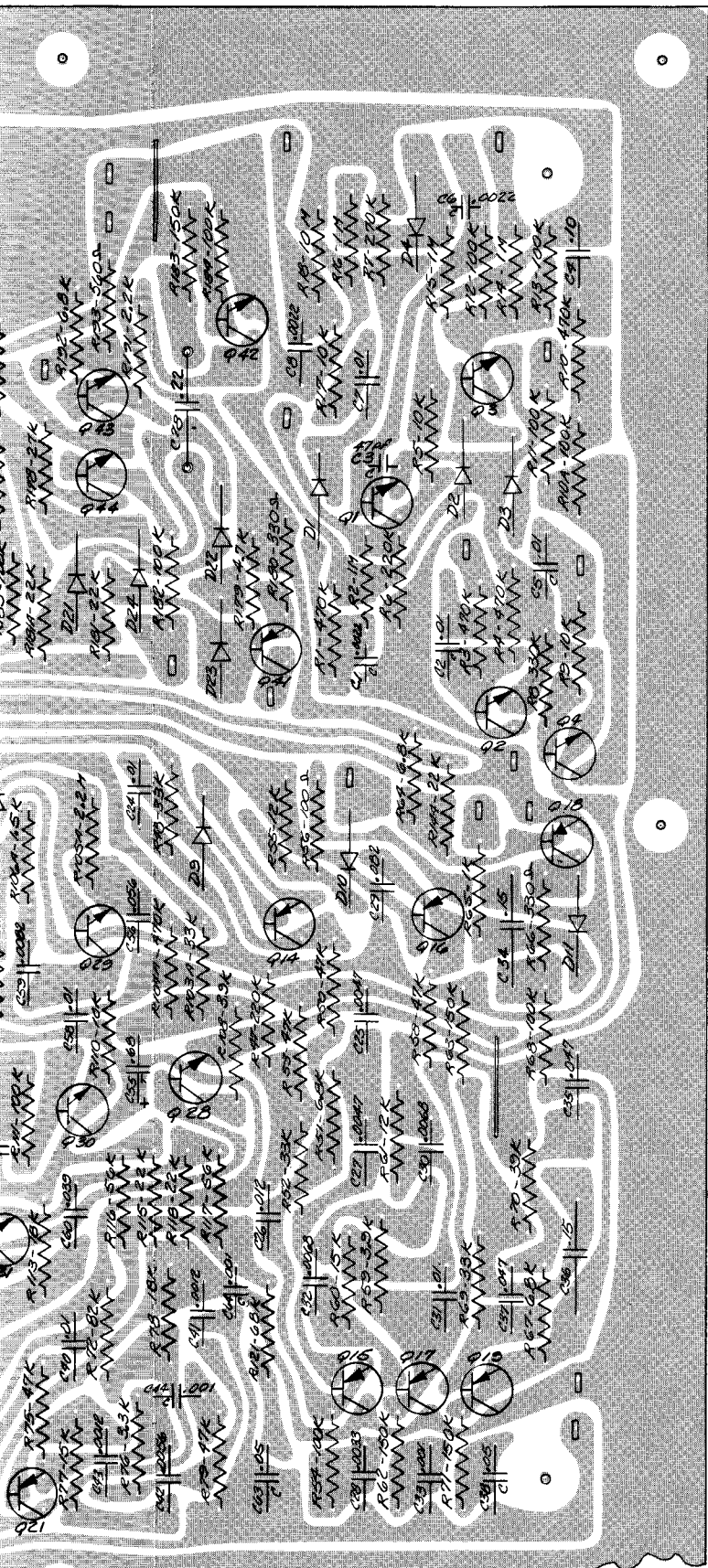

NOTES:

1. REFERENCE SCHEMATIC R501-060567 (121), R501-061014 (127), D501-061309 (128 F), D501-061354 (128 R)
2. PIN WIRING DIAGRAM C501-060471 (121), C501-061029 (127), C501-061449 (128 F), C501-061460 (128 R)
3. FINAL ASSY MUST INCLUDE LABEL MARKED 500-060-470

RELEASED

Ord. No. RN 650
Date 11 25 174

RECORD OF CHANGE

⑤ REDRAWN 2 TIMES
5/25, NO CHANGE,
NO CH 9-17-74 KMB

93	1	S205-470	CAPACITOR 47M CERAMIC
92	1	S244-25-225-1	CAPACITOR 2.2M TANT.
91	1	S244-25-225-1	CAPACITOR 2.2M TANT.
90	1	S239-106-10	RESISTOR 10M 1%w 10%
89	X	S 184-4	SOLDER (IRON)
88	X	S 184-3	SOLDER (DIP)
87	X	S137-4	BARE COPPER WIRE
86	1	B503-04192	MINI-POT 100K
85	3	S244-25-105-2	CAPACITOR 1uF TANT.
84	1	S244-35-684-1	.68 TANT.
83	1	S211-025-100	100uF 25 V
82	1	S211-025-010	10uF 25 V
81	1	S211-025-001	1uF 25 V
80	3	S210-503	.05uF CERAMIC
79	4	S205-203	.02uF
78	2	S205-103	.01uF
77	6	S205-222	.0022uF
76	4	S205-102	.001uF
75	1	S205-471	470M CERAMIC
74	1	S232-01-564	.56M NYLAR
73	2	224	.22uF
72	2	154	.15uF
71	5	124	.12uF
70	1	823	.082uF
69	1	683	.068uF
68	3	563	.056uF
67	2	473	.047uF
66	1	393	.039uF
65	1	333	.033uF
64	3	223	.022uF
63	1	123	.012uF
62	5	103	.010uF
61	1	822	.0082uF
60	2	682	.0068uF
59	2	562	.0056uF
58	5	472	.0047uF
57	6	392	.0039uF
56	1	332	.0033uF
55	E	272	.0027uF
54	1	222	.0022uF
53	1	182	.0018uF
52	2	122	.0012uF
51	3	S232-01-102	CAPACITOR .001uF NYLAR
50	1	S239-395-10	RESISTOR 3.9M 1%w 10%
49	3	225	2.2M
48	7	105	1M
47	1	824	820K
46	6	474	470K
45	3	334	330K
44	1	274	270K
43	3	224	220K
42	5	154	150K
41	22	104	100K
40	1	823	82K
39	4	683	68K
38	2	563	56K
37	24	473	47K
36	2	393	39K
35	7	333	33K
34	3	273	27K
33	18	223	22K
32	6	183	18K
31	3	153	15K
30	4	123	12K
29	12	103	10K
28	2	822	8.2K
27	8	682	6.8K
26	1	562	5.6K
25	4	472	4.7K
24	4	392	3.9K
23	3	332	3.3K
22	1	272	2.7K
21	3	222	2.2K
20	2	182	1.8K
19	3	152	1.5K
18	16	102	1K
17	1	821	820Ω
16	1	561	560Ω
15	6	331	330Ω
14	2	221	220Ω
13	1	101	100Ω
12	1	S239-680-10	68Ω 1%w 10%
11	1	S245-2051	RESISTOR 2.05K 1w 1%
10	2	AS07-060150	I.C. SOCKET NEST-8 CONN.
9	2	AS07-060149	I.C. SOCKET NEST-12 CONN.
8	40	AS07-059132	I.C. SOCKET
7	1	AS14-058249	I.C. RHYTHM COUNTER
6	1	AS14-059739	I.C. R.O.M. #3
5	26	AS14-042791	DIODE MED. VOLTAGE
4	1	AS14-047829	TRANSISTOR MED. POWER PNP
3	15	AS14-044910	TRANSISTOR PNP
2	29	AS14-033338	TRANSISTOR NPN
1	1	C505-060469	RHYTHM SECTION VOICE B'D RH.

ITEM REQD PART NO. PART NAME

DATE 9-5-74 DWN. BRADY CDR. 91774 APPD. R.L. DWN. SCALE 2X USED ON 121, 127 PART NAME RHYTHM SEC. VOICE B'D ASSEMBLY

PRINT DISTRIBUTION	CINL FILE	GR	COOL	PAY. 3 BL.	DEG. 3 BL.	E.P.T.	FIG. 1	RM 503-121-17 GR 3	IT.
--------------------	-----------	----	------	------------	------------	--------	--------	--------------------	-----

ALL DRAWINGS AND SPECIFICATIONS ARE AND REMAIN THE PROPERTY OF THE BALDWIN PIANO & ORGAN CO. AND MUST BE RETURNED TO THE BALDWIN PIANO & ORGAN CO. UPON THE COMPLETION OF THE PROJECT. NO REPRODUCTION OR DISSEMINATION OF THIS INFORMATION IS PERMITTED WITHOUT THE WRITTEN PERMISSION OF THE BALDWIN PIANO & ORGAN CO. OR ITS SUCCESSORS. ANY VIOLATION OF THESE TERMS WILL BE CONSIDERED A BREACH OF CONTRACT AND WILL BE PROSECUTED TO THE FULL EXTENT OF THE LAW. UNLESS OTHERWISE SPECIFIED TOLERANCES ARE: DECIMAL ± .005 FRACTIONAL ± .015 ANGLE ± .1°

NEXT ASSEM. 500-060698 SUPERSEDES

BALDWIN PIANO & ORGAN CO.
CINCINNATI, OHIO

D 500-060470 E

4

15

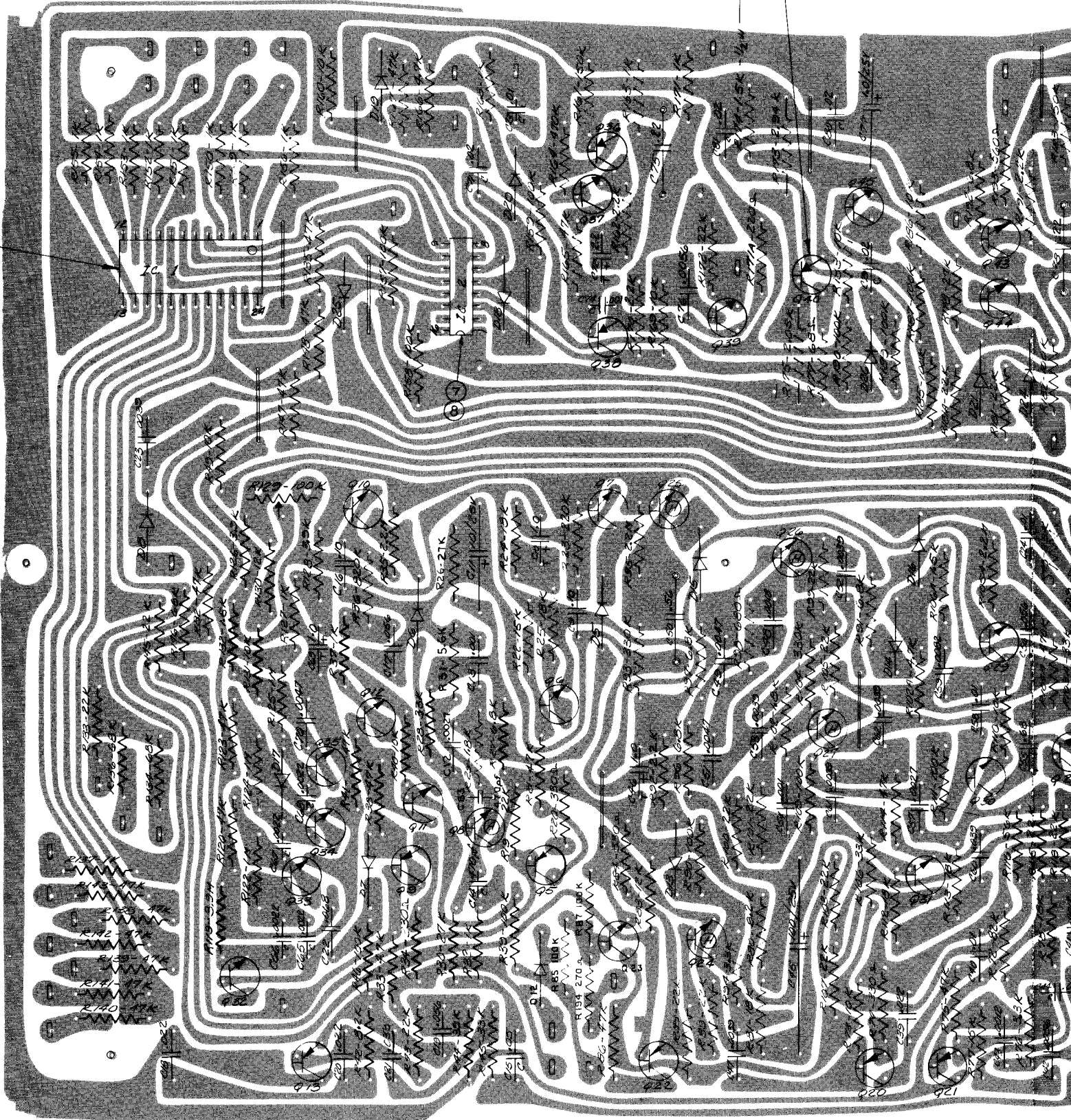

LEGEND: "C" DENOTES CERAMIC CAPACITOR
 "T" DENOTES TANTALUM CAPACITOR

CAPACITORS UNMARKED ARE MYLAR
 CAPACITORS MARKED WITH A POLARITY
 SIGN ARE ELECTROLYTIC.

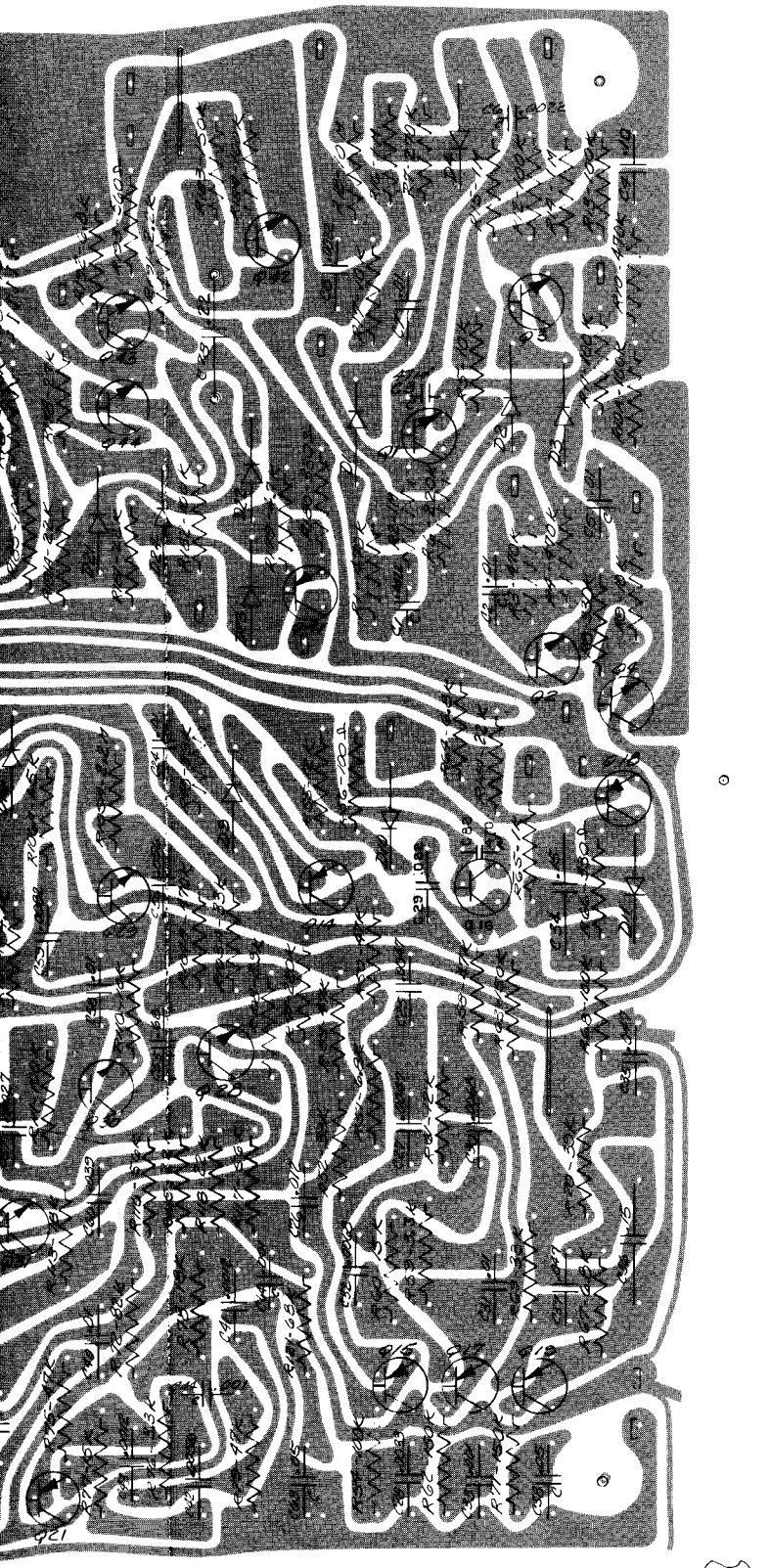

NOTES:

1. REFERENCE SCHEMATIC R501-060567 (121), R501-061014 (127), D501-061309 (128F),

2. PIN WIRING DIAGRAM C501-060471 (121), C501-061029 (127), C501-061449 (128F), C501-061450 (128R)

3. FINAL ASSY MUST INCLUDE LABEL MARKED 500-060-470K

ITEM REQ'D	PART NO.	PART NAME
95	1	S239-152-10 RESISTOR 1.5K 10% 1/2W
94	1	S239-271-10 RESISTOR 270Ω 10% 1/2W
93	1	S205-470 CAPACITOR 47 PF CERAMIC
92	1	S244-25-225-1 CAPACITOR 2.2 μF TANT.
91	1	S245-2041 RESISTOR 2.04K IN 1%
90	1	S239-106-10 RESISTOR 10M 1/2W 10%
89	X	S134-4 SOLDER (IRON)
88	X	S134-3 SOLDER (DIP)
87	X	S137-4 BARE COPPER WIRE
86	1	B509-04102 MINI-POT 100K
85	3	S244-35-105-2 CAPACITOR 1μF TANT.
84	1	S244-35-681-1 .05 TANT.
83	1	S211-025-100 100μF 25V
82	1	S211-025-010 10μF 25V
81	1	S211-025-001 1μF 25V
80	3	S210-503 .05μF CERAMIC
79	4	S205-203 .02μF
78	3	S205-103 .01μF
77	6	S205-222 .0022μF
76	3	S205-102 .001μF
75	3	S205-471 470 PF CERAMIC
74	1	S232-01-564 56μF NYLON
73	2	224 22μF
72	2	154 15μF
71	5	124 12μF
70	1	823 82K
69	1	683 68K
68	3	563 56K
67	2	473 47K
66	1	393 39K
65	1	333 33K
64	3	223 22K
63	1	123 12K
62	5	103 10K
61	1	822 82K
60	2	682 68K
59	2	562 56K
58	5	472 47K
57	6	392 39K
56	1	332 33K
55	2	272 27K
54	1	222 22K
53	1	182 18K
52	2	122 12K
51	3	S232-01-102 CAPACITOR .001μF NYLON
50	1	S239-395-10 RESISTOR 3.9M 1% 10%
49	3	S239-225-10 2.2M 1/2W 10%
48	7	S250-105 1M 1/2W 5%
47	1	824 82K
46	6	474 47K
45	3	334 33K
44	1	274 27K
43	3	224 22K
42	5	154 15K
41	22	104 10K
40	1	823 82K
39	4	683 68K
38	2	563 56K
37	24	473 47K
36	2	393 39K
35	7	333 33K
34	3	273 27K
33	18	223 22K
32	6	183 18K
31	3	153 15K
30	4	123 12K
29	12	103 10K
28	2	822 82K
27	8	682 68K
26	1	562 56K
25	4	472 47K
24	3	392 39K
23	4	332 33K
22	1	272 27K
21	4	222 22K
20	2	182 18K
19	2	152 15K
18	16	102 10K
17	1	S250-681 680Ω 1/4W 5%
16	1	S239-561-10 560Ω 1/2W 10%
15	6	S239-331-10 330Ω 1/2W 10%
14	7	S239-221-10 220Ω 1/2W 10%
13	1	S239-101-10 100Ω 1/2W 10%
12	1	S239-680-10 68Ω 1/2W 10%
11	1	S245-2051 RESISTOR 2.05K 1W 1%
10		
9	1	514-061894 DIP SOCKET-24 CONN. SEE DIM.DWG.
8	1	514-061891 DIP SOCKET-16 CONN. AS14-061889
7	1	AS14-058249 I.C. RYTHM COUNTER
6	1	AS14-053739 I.C. R.O.M. #3
5	26	AS14-042791 DIODE MED. VOLTAGE
4	1	AS14-047829 TRANSISTOR MED. POWER PNP
3	15	AS14-044510 TRANSISTOR PNP
2	23	AS14-033338 TRANSISTOR NPN
1	1	C505-060469 RHYTHM SECTION VOICE 8'D RH

RELEASED

Ord. No. RN 650
Date 11/28/74

RECORD OF CHANGE

- ⑥ REDRAWN 2 TIMES
NO CN 3-17-74 KMB
- ⑦ C73 WAS .001μF.
R59 WAS 3.9K.
C.N. 16, 099 10-29-74 W.R.M.
- ⑧ DELETED ITEMS 8, 9 & 10
IT. 8 WAS A507-060132
IT. 9 WAS A507-060149
IT. 10 WAS A507-060150
ADDED NEW ITEMS B # 9.
CN16, 163 1-22-75 DP
- ⑨ CHGDR92 FROM
220Ω TO 2.2K
CN 16, 171 K71B 2-19-75
- ⑩ ADDED C82 (AT Q10)
C83 (AT Q8) & R134 (AT
Q23).
C.N. 16, 430
9-25-75
R.M.
- ⑪ ALL RESISTORS WERE
S239-1/2W 10%
R174 NOT CHANGED
CN16, 532 1-29-74 R/M

DATE 9-5-74	DWN. BRADY	CHKD. 9-11-74	APPD. R6	DWN. SCALE 2X	USED ON 127 121, 123	PART NAME	
PRINT	CIN.	GR.	CON.	PAY.	DEQ.	E. P. T.	
DISTRIBUTION	FILE			BL. 12R	3 BL.		
ALL DRAWINGS AND SPECIFICATIONS ARE AND REMAIN THE PROPERTY OF THE BALDWIN PIANO & ORGAN CO. AND MUST BE RETURNED TO IT. ALL SPECIFICATIONS ARE CONFIDENTIAL AND ARE NOT TO BE DISCLOSED TO ANY PERSON OTHER THAN THOSE TO WHOM THEY ARE SENT. NO UNWRITTEN SPECIFICATIONS OR OTHER DATA BELONGING TO THE BALDWIN PIANO & ORGAN CO. WHICH MAY BE FURNISHED TO MANUFACTURERS OR OTHERS FOR ANY PURPOSE ARE TO BE RELEASED BY MANUFACTURER OR OTHERWISE AS IN ANY AGREEMENT LICENSING THE HOLDER OR ANY OTHER PERSON OR CORPORATION OR CONFERRING ANY RIGHTS OR PERMISSION TO MANUFACTURE, USE OR SELL ANY PATENTED INVENTION THAT MAY IN ANY WAY BE RELATED THERETO.						NEXT ASSEM 500-060698	SUPERSEDES
BALDWIN PIANO & ORGAN CO. CINCINNATI, OHIO						D	500-060470 K

BRUSH

SNARE DRUM

ACCENT

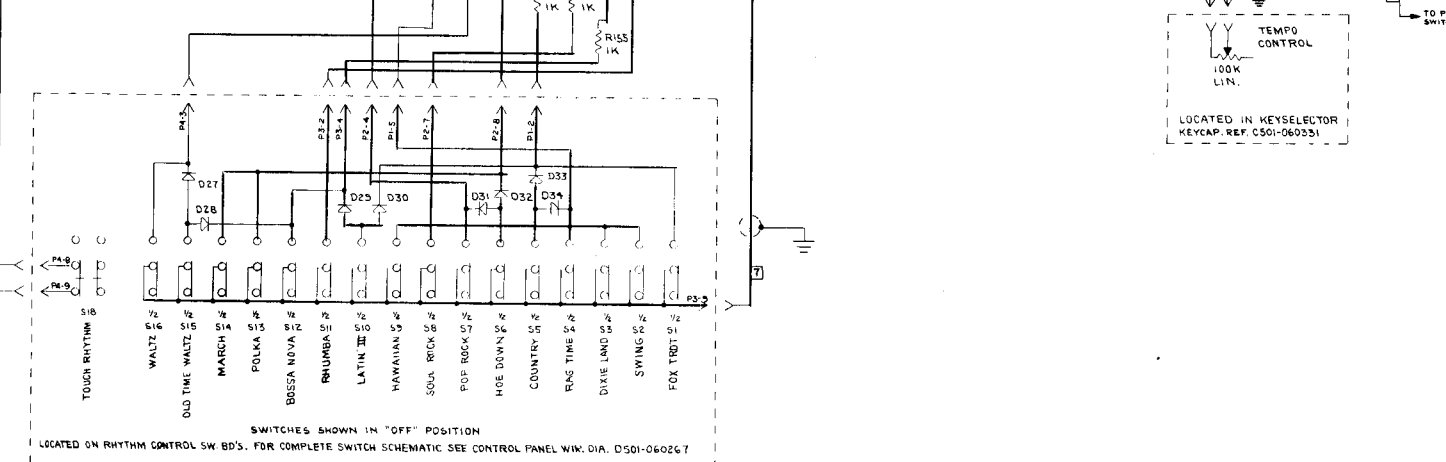
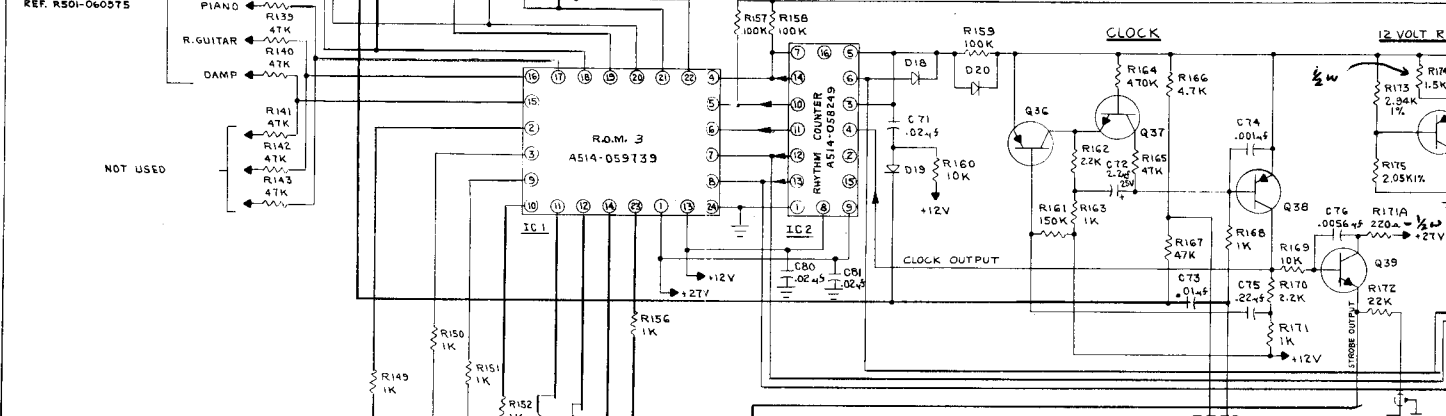
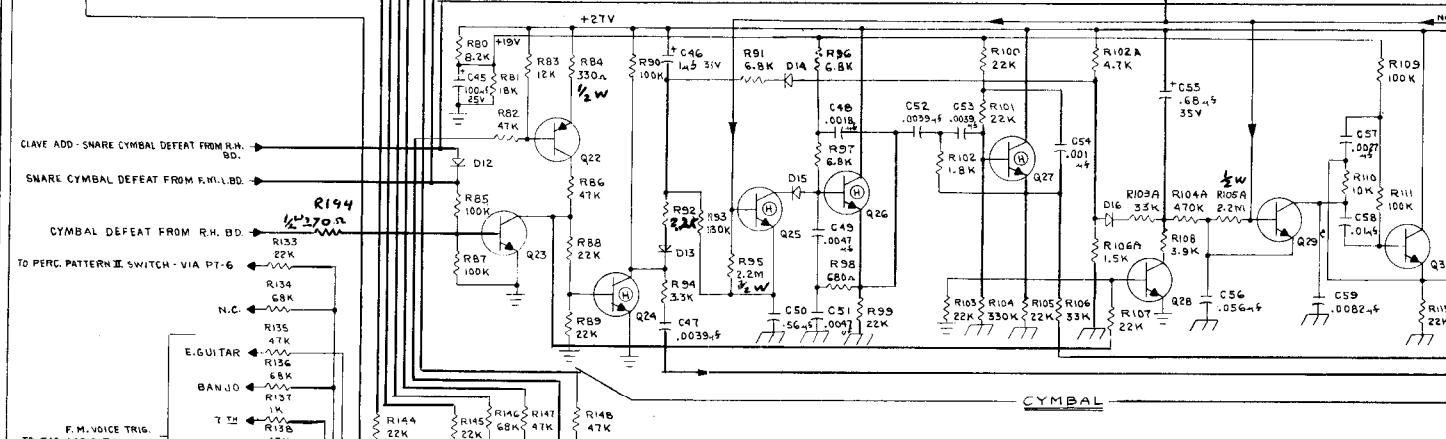
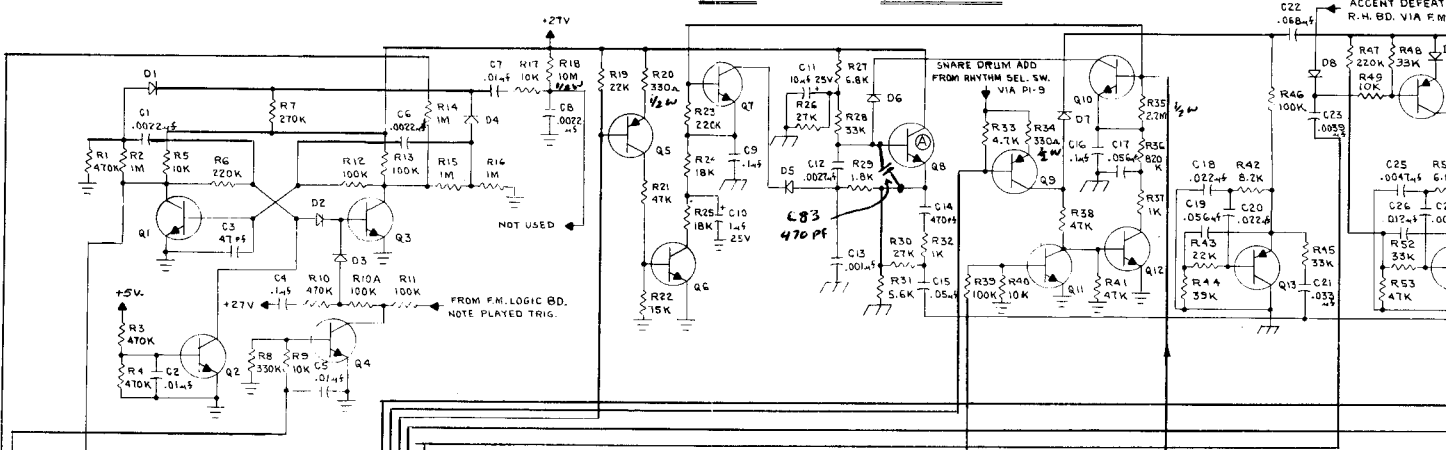

SWITCHES SHOWN IN "OFF" POSITION
 LOCATED ON RHYTHM CONTROL SW. BD'S. FOR COMPLETE SWITCH SCHEMATIC SEE CONTROL PANEL WIR. DIA. D501-060267

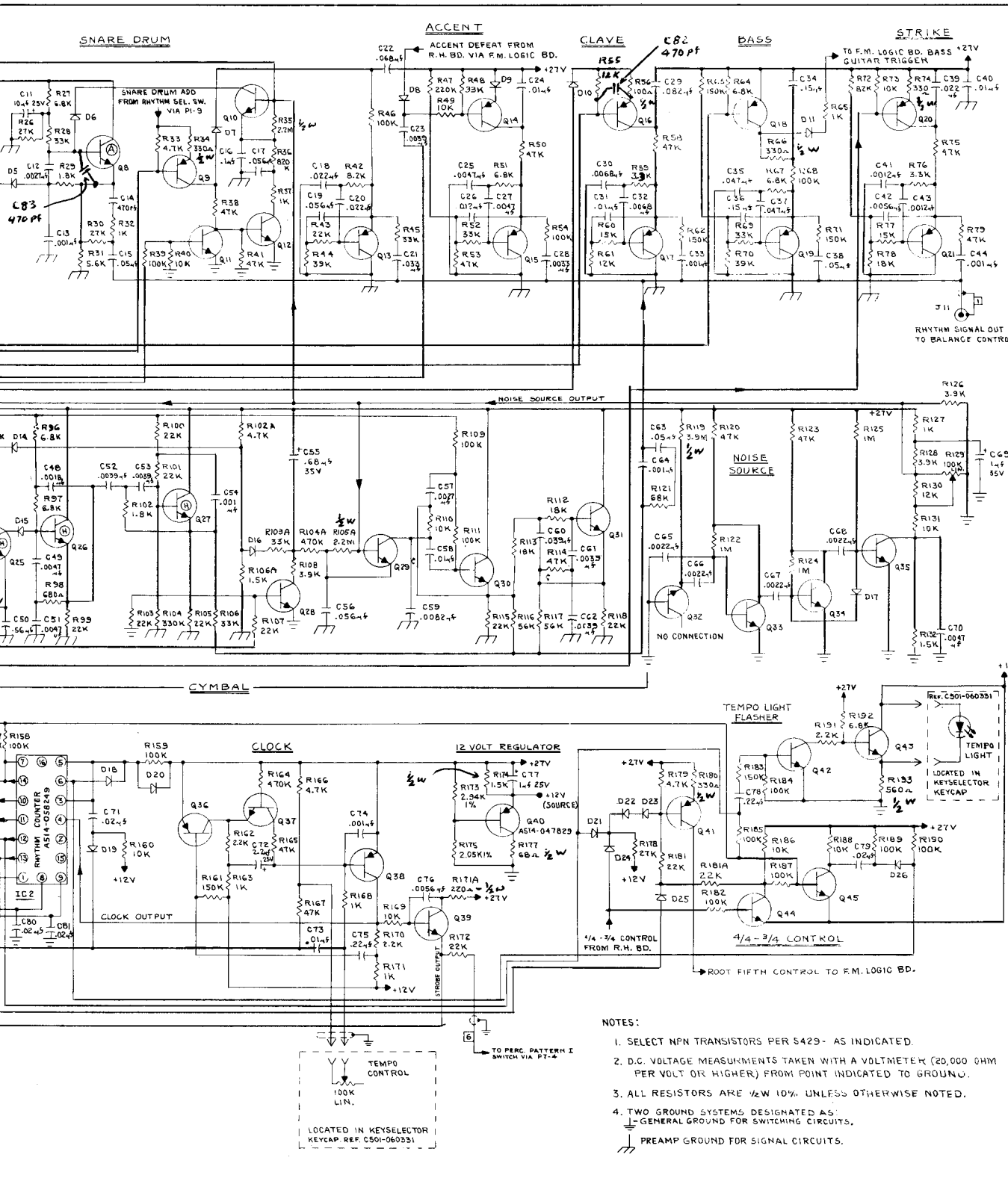

RELEASED
Ord. No. R 650
Date 1/11/74

RECORD OF CHANGE

A) R40 WAS 100K. CN 15,753 D.D. 2-2-70
B) C72 WAS 1K. 35K. R174 WAS 100K. CN 15,760 A.A.S. 3-7-74
C) CHANGED GROUND ROUTING. CN 15, 923 X.F.D. C-7-79
D) C3 WAS 470 PF. C14 WAS WERE .001UF. ADDED C80 & B1. CN 15,970 D.D. 7-16-79

F) R92 CHANGED FROM 220Ω TO 2.2K CN 16,191 2-17-75

G) ADDED C82 AT Q16, R194 AT Q23, AND C83 AT Q8 CN 16430 9-19-75

E) R57 CHANGED FROM 3.9K TO 3.3K. C73 CHANGED FROM .001UF TO .01UF

H) CHANGE FROM 1/4W TO 1/2W RESISTORS ALL EXCEPT R18, R20, R34, R35, R56, R66, R74, R84, R95, R105A, R119, R171A, R174, R177, R180, R193, R194. CN 16532 1-29-76

- NOTES:
1. SELECT NPN TRANSISTORS PER S429- AS INDICATED.
 2. D.C. VOLTAGE MEASUREMENTS TAKEN WITH A VOLTMETER (20,000 OHM PER VOLT OR HIGHER) FROM POINT INDICATED TO GROUND.
 3. ALL RESISTORS ARE 1/2W 10% UNLESS OTHERWISE NOTED.
 4. TWO GROUND SYSTEMS DESIGNATED AS:
 - GENERAL GROUND FOR SWITCHING CIRCUITS.
 - PREAMP GROUND FOR SIGNAL CIRCUITS.

DATE 12-17-73	DRW D. DIEHL	CHK	APPD	DRW SCALE	USED ON	PART NAME	
COMP. NO'S	REV	CHG	GR	CON	REV	REV	
R1 - R193						RHYTHM SECTION VOICE BD.-SCHEM	
C1 - C81							
Q1 - Q45							
D1 - D34							
IC1 - 112							
UNLESS OTHERWISE SPECIFIED TOLERANCES ARE DECIMAL 1.00% FRACTIONAL 1.0% ANGLES 1.0°						FINISH	BMS 503 121-17 GR. NOTE IT
NEXT ASSEM						SUPERSEDES	
BALDWIN PIANO & ORGAN CO. CINCINNATI, OHIO						R 501-060567 H	

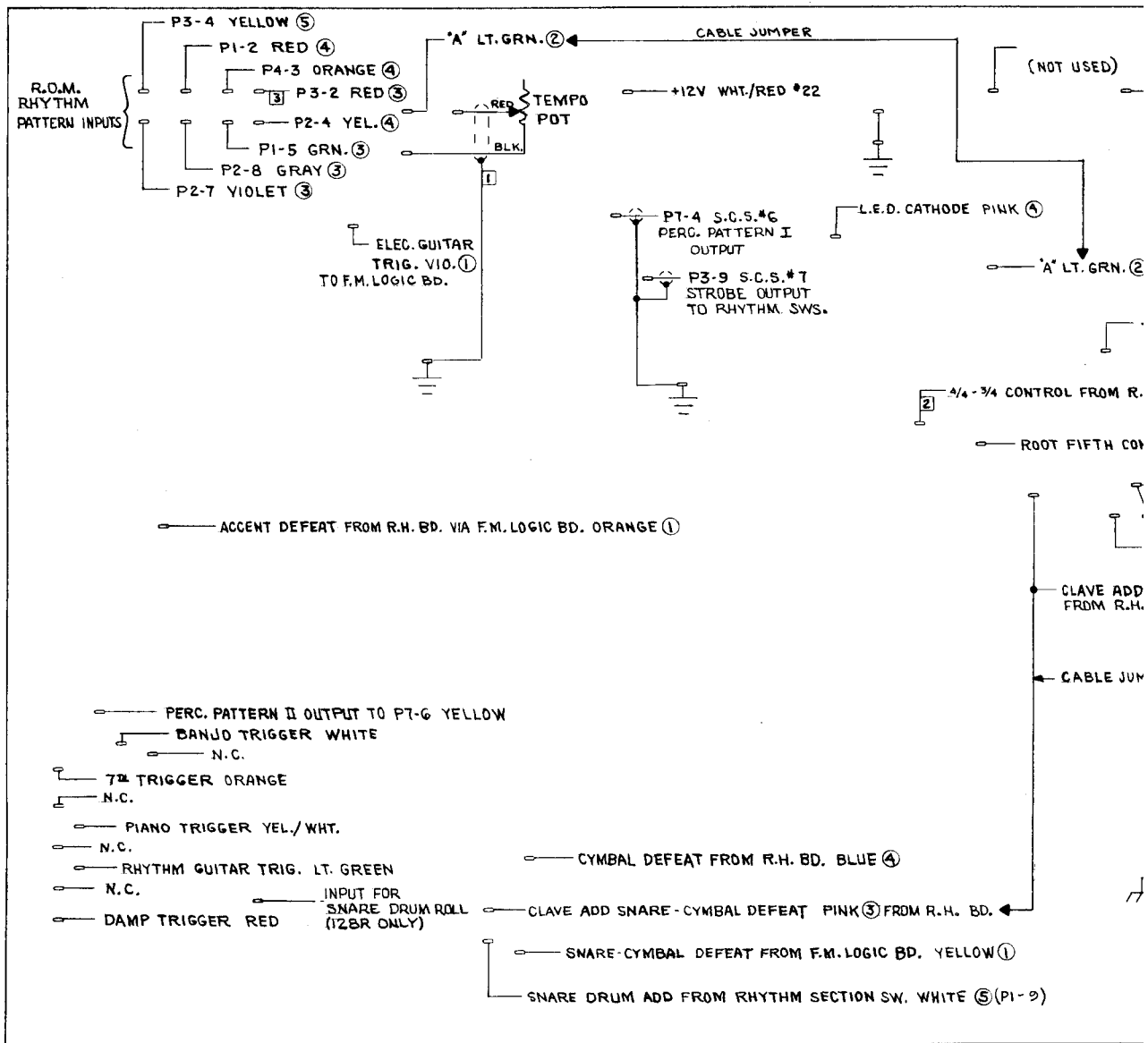

NOTES:
 1. REF. R501-060567 - RHYTHM SECTION VOICE BD. SCHEMATIC.

DATE 1-21-74	DWN. D. DIEHL		
PRINT	CIN.	GR.	C
DISTRIBUTION	S		
<small>ALL DRAWINGS AND SPECIFICATIONS ARE AND REM RETURNED TO IT. ALL SPECIFICATIONS ARE CONSIDERED TO WHICH THEY ARE SENT. NO DRAWINGS, SPECIFICA WHICH MAY BE FURNISHED TO MANUFACTURERS OF OTHERWISE AS IN ANY MANNER LICENSING THE HOLD OR PERMISSION TO MANUFACTURE, USE OR SELL A</small>			
UNLESS OTHERWISE SPECIFIED TOLERAN			

RELEASED

Ord. No. R.N. 650
Date 7/13/74

RECORD OF CHANGE

ADDED TERMINAL & FUNCTION
C.N.15,869 M.S. 4-29-74

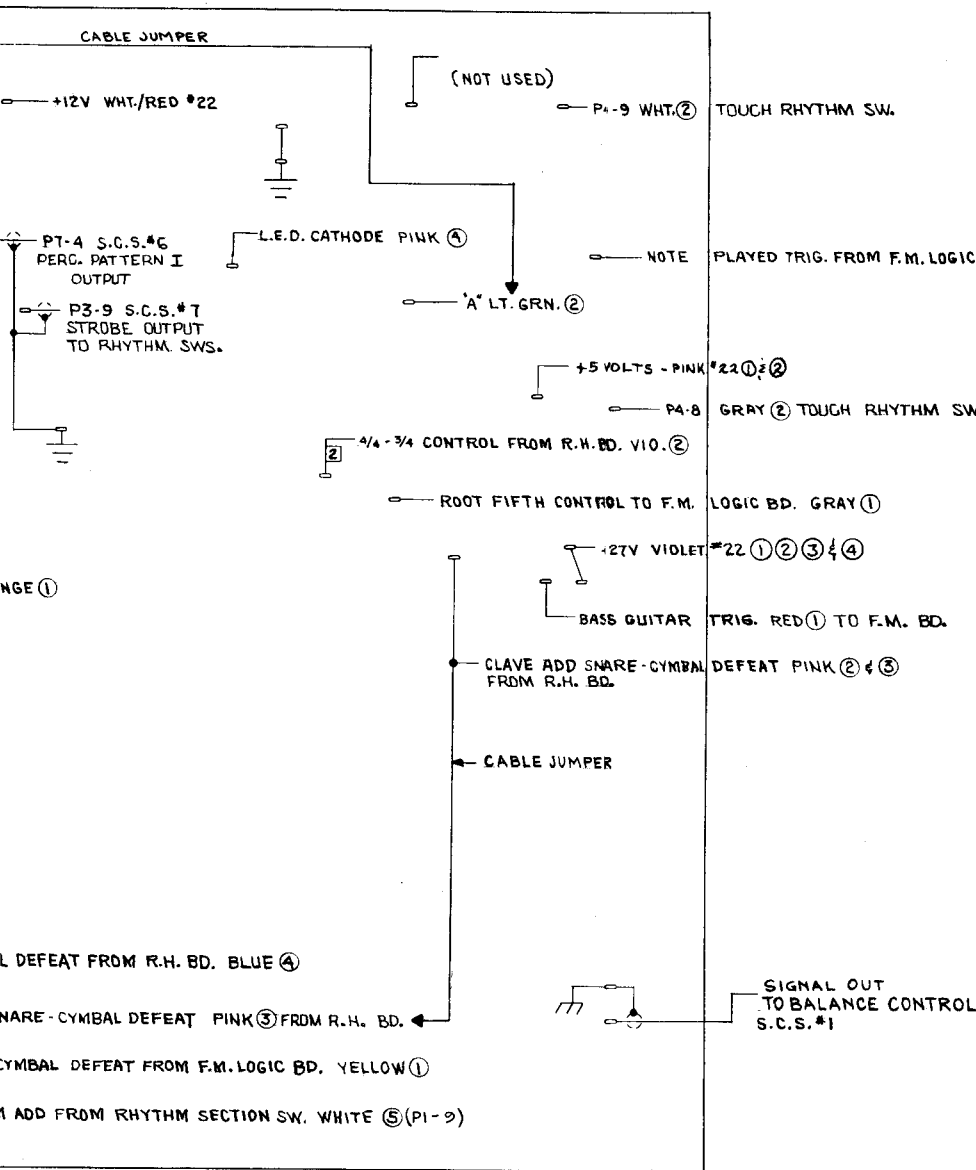

RHYTHM SECTION VOICE BD. SCHEMATIC.

DATE 1-21-74		DWN. D. DIEHL		CH'D. <i>D.M.L.</i>	APP'D. <i>Rab</i>	DWN. SCALE FULL	USED ON ORGAN 121	PART NAME	
PRINT	CIN.	GR.	CON.	FAY.	DEQ.	E. P. T.	REQ.	RHYTHM SECTION VOICE BD.-WIR. DIA.	
DISTRIBUTION	S			5BL-1BR	5 BL.		FINISH	B/M 503-121-17	GR. NOTED IT.
<small>ALL DRAWINGS AND SPECIFICATIONS ARE AND REMAIN THE PROPERTY OF THE BALDWIN PIANO & ORGAN CO. AND MUST BE RETURNED TO IT. ALL SPECIFICATIONS ARE CONFIDENTIAL AND ARE NOT TO BE DISCLOSED TO ANY PERSONS OTHER THAN THOSE TO WHOM THEY ARE SENT. NO DRAWINGS, SPECIFICATIONS OR OTHER DATA BELONGING TO THE BALDWIN PIANO & ORGAN CO. WHICH MAY BE FURNISHED TO MANUFACTURERS OR OTHERS FOR ANY PURPOSE ARE TO BE REGARDED BY IMPLICATION OR OTHERWISE AS IN ANY MANNER LICENSING THE HOLDER OR ANY OTHER PERSON OR CORPORATION OR CONVEYING ANY RIGHTS OR PERMISSION TO MANUFACTURE, USE OR SELL ANY PATENTED INVENTION THAT MAY IN ANY WAY BE RELATED THERETO.</small>								NEXT ASSEM.	
UNLESS OTHERWISE SPECIFIED TOLERANCES ARE: DECIMAL ±.005 FRACTIONAL ±.015 ANGLE ±.12°								SUPERSEDES	
BALDWIN PIANO & ORGAN CO. CINCINNATI, OHIO							C	501-060471	A

PREAMPLIFIER AND EXPRESSION CONTROL

Reference: Preamplifier Schematic - C501-060320

The Model 121 organ employs one preamplifier circuit, consisting of three (3) NPN transistors.

Signal input to the preamplifier is applied through C1 to the base of Q1 transistor, which operates as a voltage amplifier stage. The D.C. condition of the first stage ($I_c = 50\mu A$) is set by its base current supplied from the Q2 emitter through R9, R8 and R5 resistors. The collector of the Q1 transistor is directly (D.C.) coupled to the base of the second stage Q2 transistor so that the R6 resistor supplies current for the Q1 collector and Q2 base. The second stage (Q2), operating as an emitter follower, has collector current of about 1.3mA. A portion of the emitter (A.C.) output, determined by R9 and R10 divider resistors and a variable feedback circuit (D1 and D2 in parallel to D4 and D5) is applied back to the base of Q1 as negative feedback controlling the gain of the preamplifier.

The emitter of Q2 is A.C. coupled via C11 capacitor to the base of the last stage Q3, operating as a voltage amplifier. Base current for Q3 is supplied by resistor R14, which sets the collector current to about 2.5mA.

Using VTVM or voltmeter (20,000 Ohms/Volts), D.C. voltages given in the following chart should be measured with respect to ground.

	EMITTER	BASE	COLLECTOR
Q1	0V	+0.6V	+2.8V
Q2	+2.2V	+2.8V	+12 V
Q3	0V	+0.6V	+11.8V

Supply voltages are +27V for 3rd (Q3) stage and +22V for 1st and 2nd (Q1 and Q2) stages.

EXPRESSION CONTROL CIRCUIT

Referring to the Preamplifier Schematic C501-060320, the Expression Pedal circuit consists of a controlling element, Q4, and a double feedback loop around the first two stages of the preamplifier.

When the expression pedal potentiometer is fully open (up) it back biases transistor Q4 (base at emitter potential). This causes the collector of Q4 (Point 1) to be highly positive with respect to the emitter potential (Point 2).

Referring to the preamplifier feedback circuitry, when Point 1 is highly positive with respect to Point 2, current will flow through R20, D1 and D2 (common anode connection), D4 and D5 (common cathode connection), through R26 to Point 2.

Both pairs of feedback diodes will be forward biased, thus lowering the gain of the preamplifier.

When the expression pedal is fully depressed (down), positive potential is applied to the base of Q4 which will saturate. This causes Point 1 and Point 2 to be at approximately the same potential, causing the feedback diodes to be non-conductive and rendering the preamplifiers in the high gain state.

NOISE ELIMINATOR CIRCUIT:

The Noise Eliminator Circuit (Q5 and Q6), located on the Preamplifier Board assembly, initially defeats operation of the first stage of the Power Amplifier (Q1 on Schematic C501-051929) to prevent the switch on transient, fluorescent light switch on noise, Rhythm and Organ voices from being heard until the Power Supply circuits have stabilized. Otherwise, the Rhythm circuits could be gated by voltage transients created when the organ is turned on.

When the organ is first turned on, Q5 transistor will be turned on by the charging action of C22 capacitor. As capacitor C22 charges, base bias is available for Q5 transistor. At the same time, Q6, a PNP transistor, will be saturated, providing +27V bias via its collector circuit and R34 to saturate Q1 transistor in the Power Amplifier circuit. When C22 fully charges, Q5 and Q6 cut off, permitting the organ signals to be fed to the Power Amplifier circuit. Capacitor C21 (together with R1 and R26 located on the Power Amplifier circuit) delays the application of +53 V.D.C. supply to the power Amplifier driver stage (Q3) when the organ is just turned on, thus preventing additional audible transients.

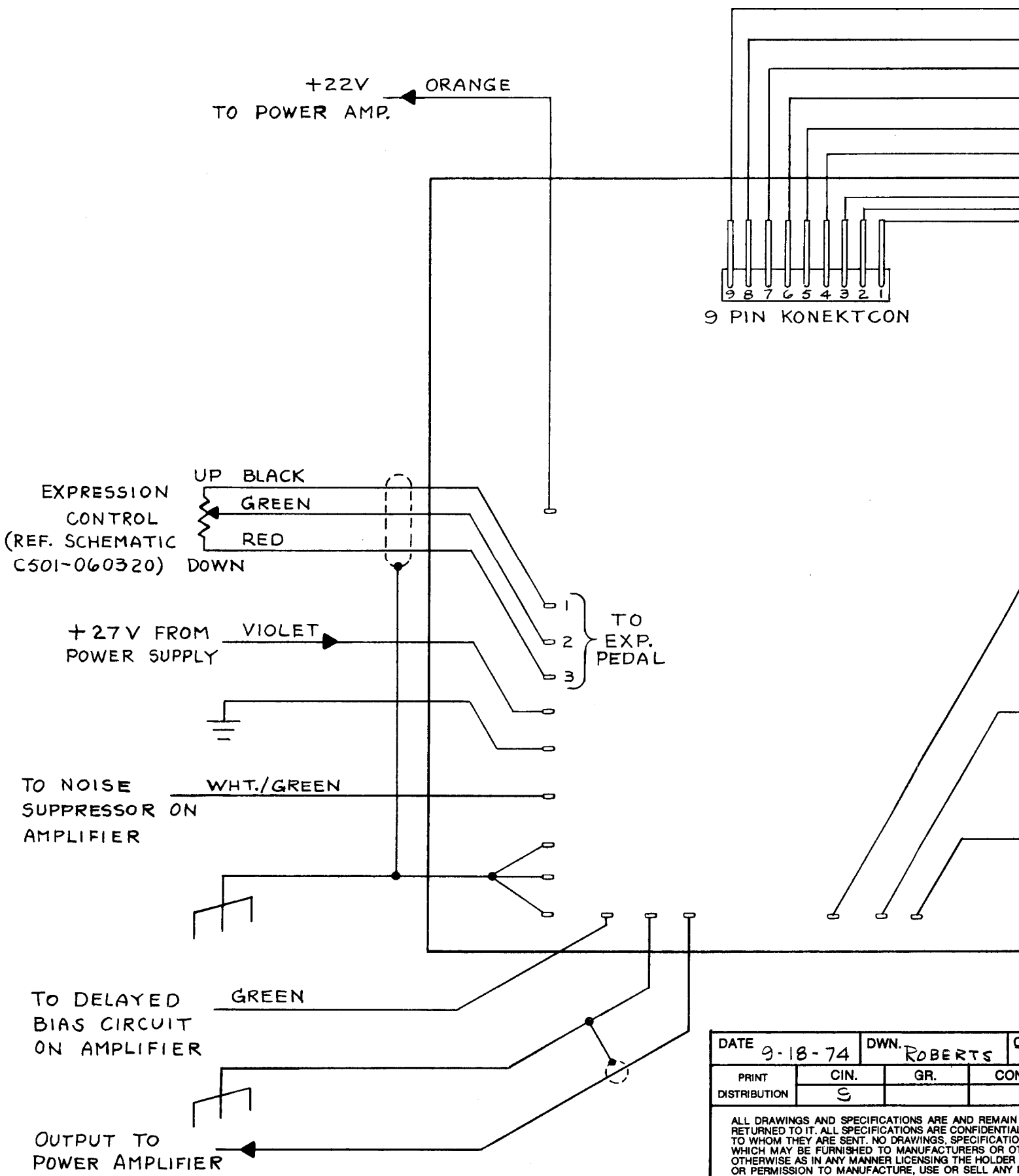

DATE	9-18-74	DWN.	ROBERTS	C
PRINT	CIN.	GR.	CON	
DISTRIBUTION	S			

ALL DRAWINGS AND SPECIFICATIONS ARE AND REMAIN RETURNED TO IT. ALL SPECIFICATIONS ARE CONFIDENTIAL TO WHOM THEY ARE SENT. NO DRAWINGS, SPECIFICATIONS WHICH MAY BE FURNISHED TO MANUFACTURERS OR OTHERS WITHOUT THE PERMISSION OF THE HOLDER. OTHERWISE AS IN ANY MANNER LICENSING THE HOLDER OR PERMISSION TO MANUFACTURE, USE OR SELL ANY PART THEREOF.

UNLESS OTHERWISE SPECIFIED TOLERANCES ARE AS SHOWN

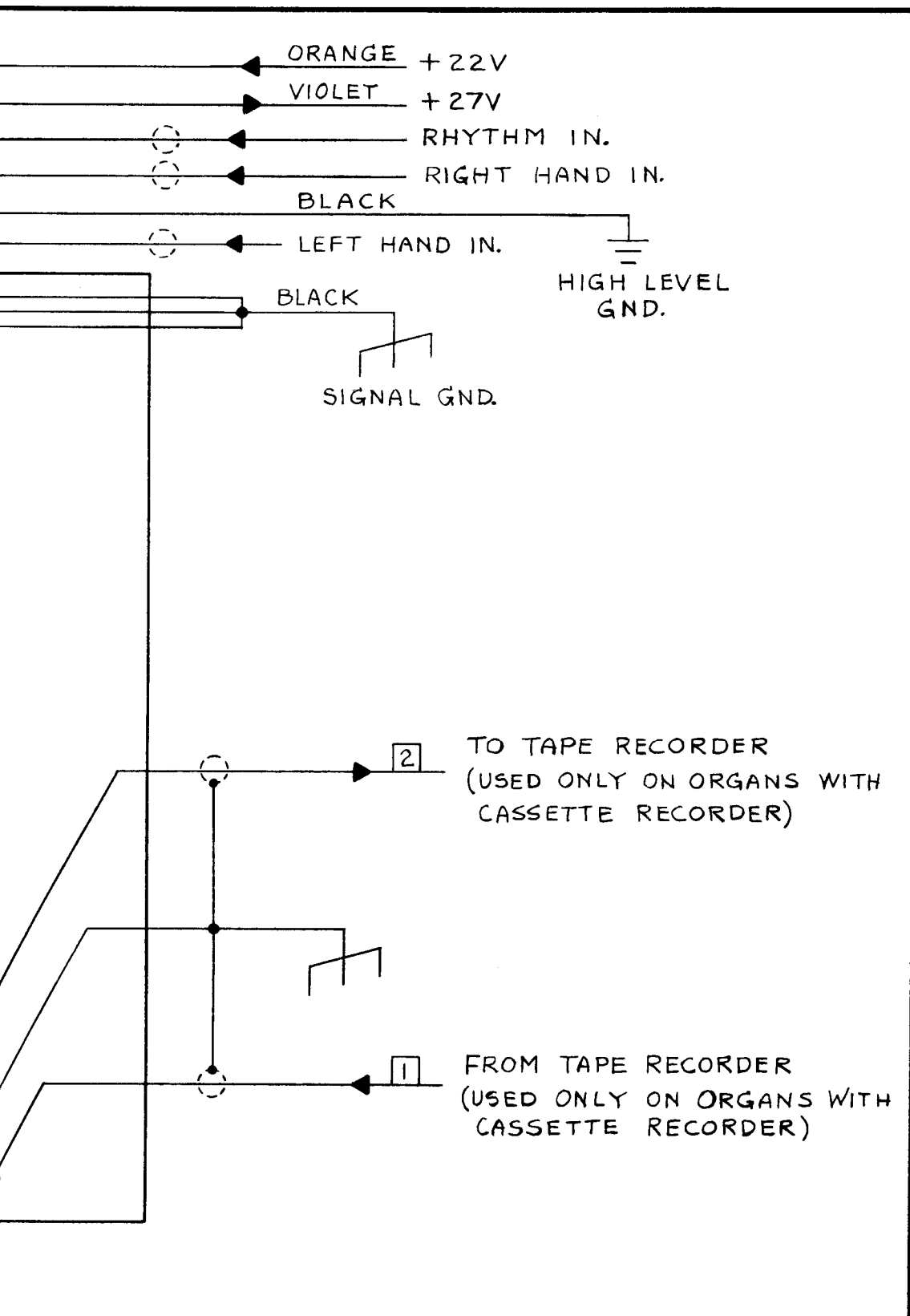

RELEASED
 Ord. No. R.N. 650
 Date 1/16/74

RECORD OF CHANGE
 A) REDRAWN -
 NO C.N. H.C.R. 9-18-74

ROBERTS		CH'D	APP'D.	DWN.SCALE	USED ON	PART NAME	
				FULL	MOD. 121	PREAMP BOARD	
DR.	CON.	FAY.	DEQ.	E. P. T.	REQ.	PIN WIRING DIAGRAM	
		X	X		FINISH	BM503-121-10 GR. NOTE IT.	
NEXT ASSEM.						SUPERSEDES B501-06044B	
Baldwin Piano & Organ Co. Cincinnati, Ohio						B	501-060448 A

ARE AND REMAIN THE PROPERTY OF THE BALDWIN PIANO & ORGAN CO. AND MUST BE KEPT CONFIDENTIAL AND ARE NOT TO BE DISCLOSED TO ANY PERSONS OTHER THAN THOSE AUTHORIZED BY THE BALDWIN PIANO & ORGAN CO. NO REPRODUCTION OR OTHER DATA BELONGING TO THE BALDWIN PIANO & ORGAN CO. MANUFACTURERS OR OTHERS FOR ANY PURPOSE ARE TO BE REGARDED BY IMPLICATION OR OTHERWISE AS THE PROPERTY OF THE BALDWIN PIANO & ORGAN CO. NO RIGHTS ARE TO BE CONVEYED BY THIS DOCUMENT TO ANY OTHER PERSON OR CORPORATION OR CONVEYING ANY RIGHTS IN ANY PATENTED INVENTION THAT MAY IN ANY WAY BE RELATED THERETO.

TOLERANCES ARE: DECIMAL ± .005 FRACTIONAL ± .015 ANGLE ± 1/2°

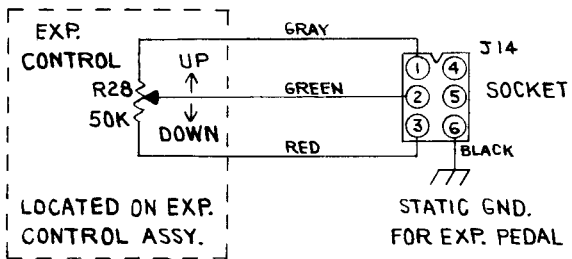
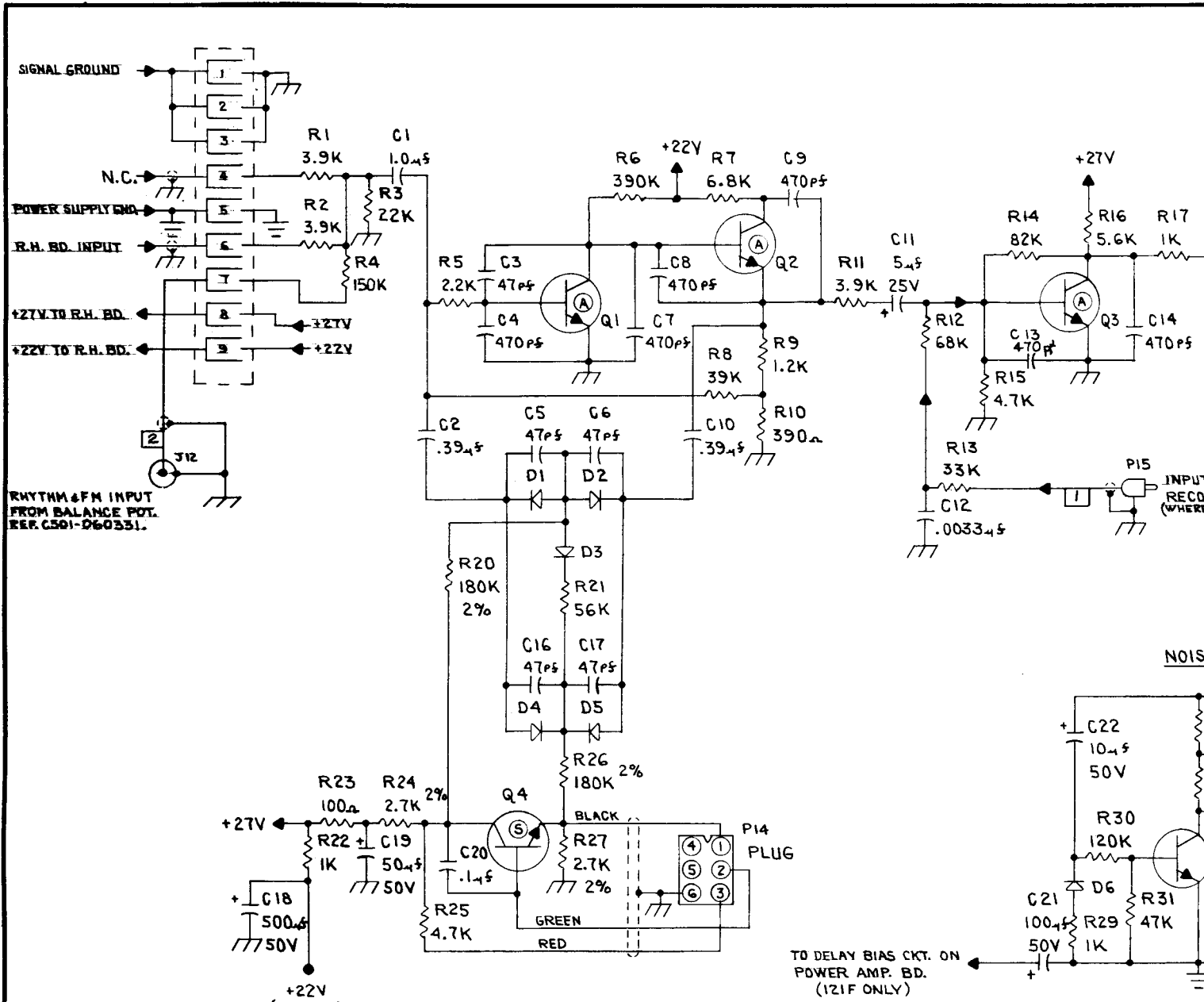

- NOTES:
1. SELECT NPN TRANSISTOR
 2. BRIDGE DIODES D1, D2,
 3. ALL RESISTORS ARE 1/4
 4. D.C. VOLTAGE MEASUR (VOLT OR HIGHER) FR

DATE	1-14-74	OWN.	D.D
PRINT DISTRIBUTION		CNL.	GR.
LAST USED		S	
R34			
C23			
Q6			
D6			

ALL DRAWINGS AND SPECIFICATIONS ARE RETURNED TO IT. ALL SPECIFICATIONS ARE TO WHOM THEY ARE SENT. NO DRAWINGS OR PERMISSION TO MANUFACTURE, USE 1 UNLESS OTHERWISE SPECIFIED

RELEASED

Ord. No. R.N. 650
Date 1/31/74

RECORD OF CHANGE

- (A) R4 WAS 82K RESISTOR
C.N. 15,760 M.S. 2-27-74
- (B) R22 WAS 2.7K
C.N. 17,118 2-4-77 RH

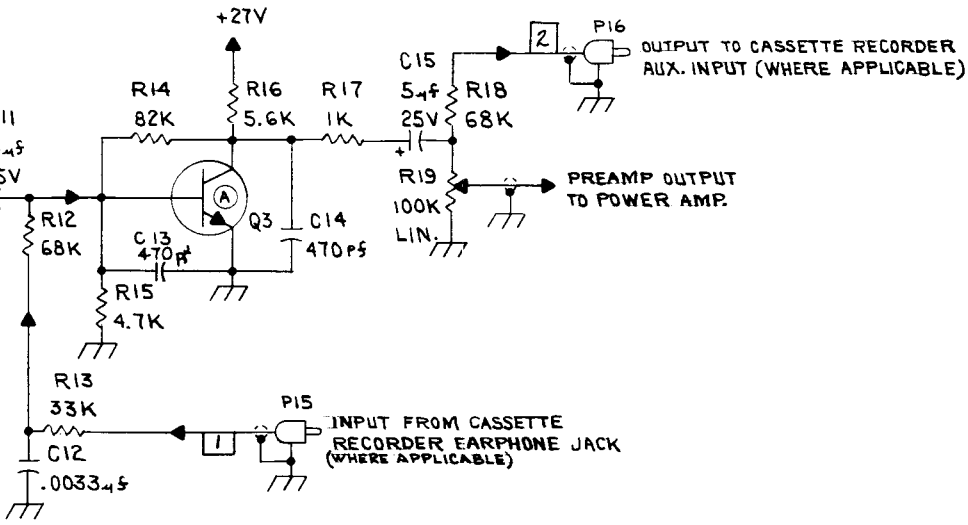

NOISE ELIMINATOR

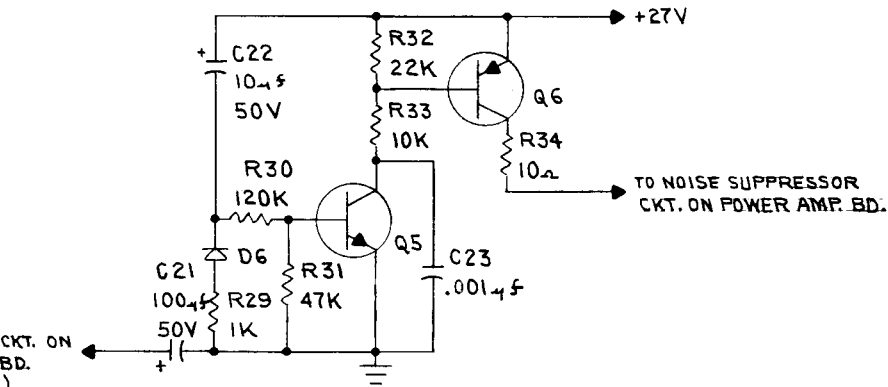

NOTES:

1. SELECT NPN TRANSISTORS PER S429- AS INDICATED.
2. BRIDGE DIODES D1, D2, D4 & D5 PER S440-1.
3. ALL RESISTORS ARE 1/2W 10% UNLESS OTHERWISE SPECIFIED.
4. D.C. VOLTAGE MEASUREMENTS TAKEN WITH A VOLTMETER (20,000 OHM PER VOLT OR HIGHER) FROM POINT INDICATED TO GROUND.

DATE	1-14-74	DWN.	D. DIEHL	CHD.	<i>Smj</i>	APPD.	<i>Zak</i>	DWN/SCALE	121 & 121W	PART NAME	PREAMP SCHEMATIC
PRINT	CIN.	GR.	CON.	FAY.	DEQ.	E.P.T.	REQ.	FINISH	RM 503-121-10	OR NOTED	FR.
LAST USED	R34	C23	Q6	D6							
<small>ALL DRAWINGS AND SPECIFICATIONS ARE AND REMAIN THE PROPERTY OF THE BALDWIN PIANO & ORGAN CO. AND MUST BE RETURNED TO IT. ALL SPECIFICATIONS ARE CONFIDENTIAL AND ARE NOT TO BE DISCLOSED TO ANY PERSONS OTHER THAN THOSE TO WHOM THEY ARE SENT. NO DRAWINGS, SPECIFICATIONS OR OTHER DATA BELONGING TO THE BALDWIN PIANO & ORGAN CO. WHICH MAY BE FURNISHED TO MANUFACTURERS OR OTHERS FOR ANY PURPOSE ARE TO BE REPRODUCED BY IMPLICATION OR OTHERWISE AS IN ANY MANNER LICENSING THE HOLDER OR ANY OTHER PERSON OR CORPORATION OR CONVEYING ANY RIGHTS OR PERMISSION TO MANUFACTURE, USE OR SELL ANY PATENTED INVENTION THAT MAY IN ANY WAY BE RELATED THEREOF.</small>										NEXT ASSEM.	SUPERSEDES
<small>UNLESS OTHERWISE SPECIFIED TOLERANCES ARE: DECIMAL ±.05 FRACTIONAL ±.015 ANGLE ±.1°</small>										BALDWIN PIANO & ORGAN CO. CINCINNATI, OHIO	C 501-060320 B

5.2 REF.

LEGEND:
E - DENOTES E
C - DENOTES C

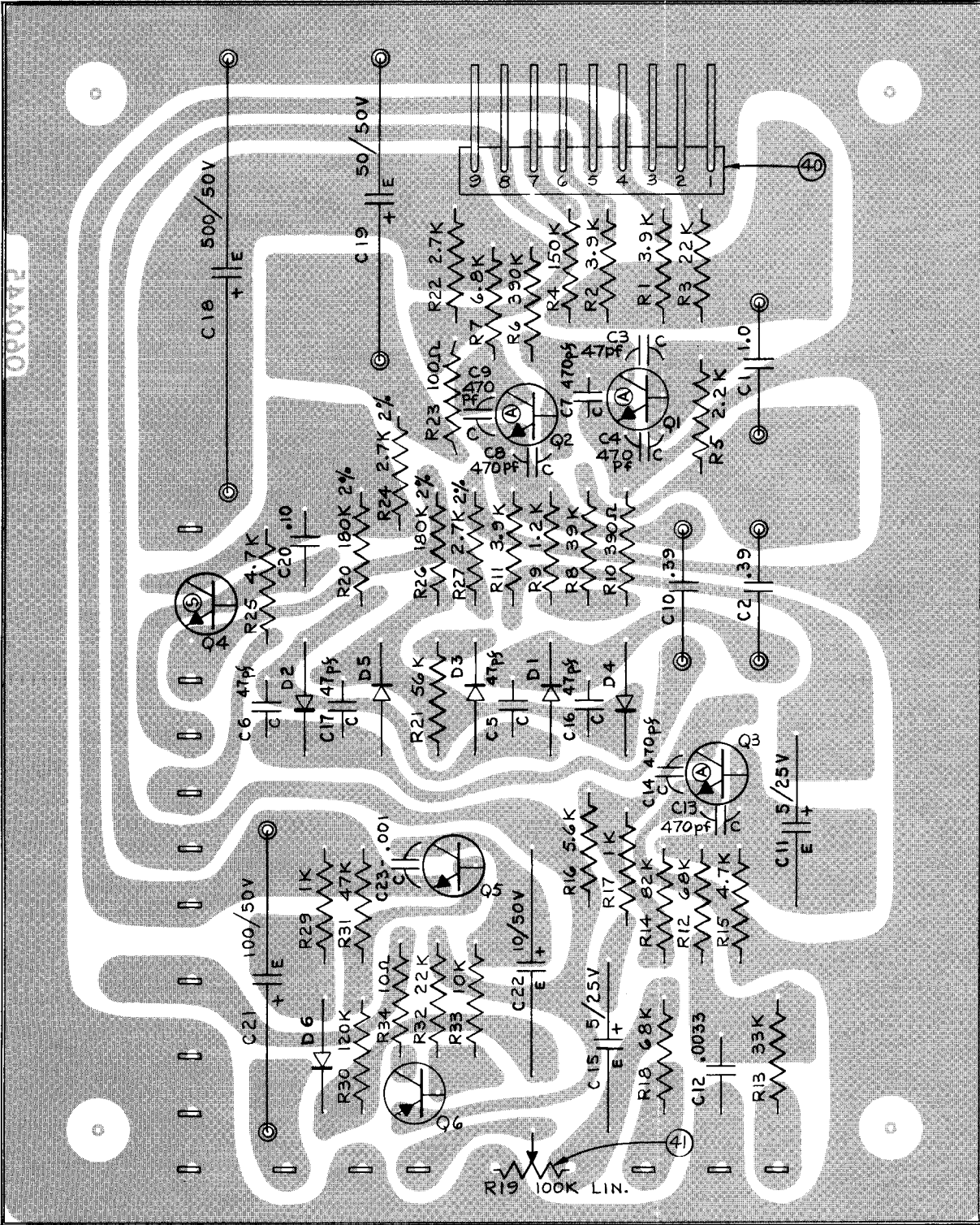

44	1	A51
43	X	S18
42	X	S13.
41	1	B50
40	1	A50
39	5	A51
38	6	A514
37	1	S211
36	1	S21
35	1	S211
34	1	S21
33	2	S21
32	1	S23
31	2	S23
30	1	S23
29	1	S23
28	1	S20
27	6	S20
26	5	S20
25	1	S23
24	1	
23	1	
22	2	
21	1	
20	1	
19	1	
18	1	
17	2	
16	1	
15	1	
14	1	
13	1	
12	2	
11	3	
10	1	
9	1	
8	1	
7	2	
6	1	
5	1	
4	1	S23
3	2	S24
2	2	S24
1	1	B50

NOTES:

1. TRANSISTORS ARE NPN SILICON EXCEPT Q6 WHICH IS PNP. Q1, Q2, & Q3 SELECTED PER S429-7. Q4 SELECTED PER S429-2.
2. SELECT DIODES D1, D2, D4, D5 PER S440-1.
3. REFERENCE PIN WIRING DIAGRAM B501-060448.
4. REFERENCE SCHEMATIC C501-060320.
5. FINAL ASSEMBLY MUST INCLUDE LABEL MARKED 500-060447 B.

DATE	9-17-74	DWN.	ROBERTS
PRINT	CIN.	GR.	CC
DISTRIBUTION	FILE		
ALL DRAWINGS AND SPECIFICATIONS ARE AND REMAIN THE PROPERTY OF THE MANUFACTURER. THEY ARE LOANED TO YOU FOR YOUR INFORMATION ONLY. THEY ARE NOT TO BE REPRODUCED OR COPIED IN ANY MANNER WITHOUT THE WRITTEN PERMISSION OF THE MANUFACTURER. ANY UNAUTHORIZED REPRODUCTION OR USE IS STRICTLY PROHIBITED.			
UNLESS OTHERWISE SPECIFIED TOLERANCE			

LEGEND:

E- DENOTES ELECTROLYTIC CAPACITOR.
 C- DENOTES CERAMIC CAPACITOR.

RELEASED

Ord. No. R.N. C50
 Date 11/16/74

RECORD OF CHANGE

A) DELETED 1 OF IT. 39
 ADDED IT. 44
 C.N. 15714 M.S. 2-4-73
 B) ADDED 1 150K RES. IT. 16
 QTY. OF IT. 23 WAS 2
 C.N. 15760 M.S. 2-27-74
 C) REDRAWN- CHANGED
 FROM "B" TO "C" & FROM
 FULL SIZE TO 2X SIZE.
 No C.N. H.C.R. 9-17-74

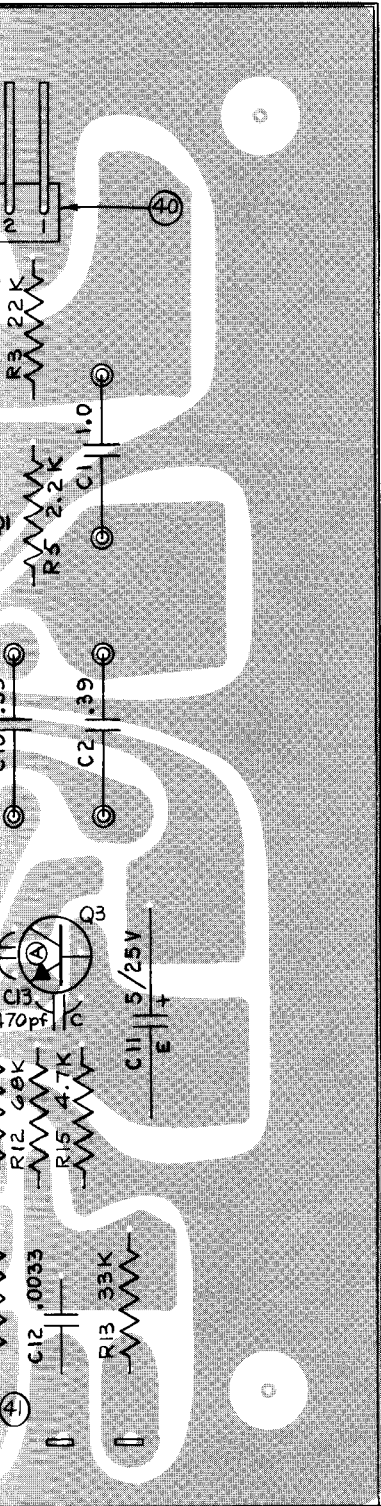

44	1	A514-044910	TRANSISTOR, PNP SILICON
43	X	S184-3	SOLDER (DIP)
42	X	S134-4	SOLDER (IRON)
41	1	B509-041912	MINIPOT, 100K LINEAR
40	1	A507-059127	KONEKTCO - (9 CONN).
39	5	A514-033338	TRANSISTOR, NPN SILICON
38	6	A514-042791	DIODE, MEDIUM VOLTAGE
37	1	S211-050-500	CAPACITOR, ELECT., 500µf 50V
36	1	S211-050-100	100µf 50V
35	1	S211-050-050	50µf 50V
34	1	S211-050-010	10µf 50V
33	2	S211-025-005	CAPACITOR, ELECT., 5µf 25V
32	1	S232-01-105	CAPACITOR, MYLAR 1.0µf
31	2	S232-01-394	CAPACITOR, MYLAR, .39µf
30	1	S232-01-104	CAPACITOR, MYLAR, .10µf
29	1	S232-01-332	CAPACITOR, MYLAR, .0033µf
28	1	S205-102	CAPACITOR, CER. .001µf
27	6	S205-471	CAPACITOR, CER. 470pf
26	5	S205-470	CAPACITOR, CER. 47pf
25	1	S239-394-10	RESISTOR 1/2W 10% 390K
24	1	124	120K
23	1	823	82K
22	2	683	68K
21	1	563	56K
20	1	473	47K
19	1	393	39K
18	1	333	33K
17	2	223	22K
16	1	154	150K
15	1	103	10K
14	1	682	6.8K
13	1	562	5.6K
12	2	472	4.7K
11	3	392	3.9K
10	1	272	2.7K
9	1	222	2.2K
8	1	122	1.2K
7	2	102	1K
6	1	391	390Ω
5	1	101	100Ω
4	1	S239-100-10	RESISTOR 1/2W 10% 10Ω
3	2	S243-2701	RESISTOR 1/2W 2% 2.7K
2	2	S243-1803	RESISTOR 1/2W 2% 180K
1	1	B505-060446	PREAMP B'D. RIVETED

Q1, Q2, & Q3 SELECTED

DATE 9-17-74	DWN. ROBERTS	CHKD. 10-8-74	APP'D. Rbk.	DWN. SCALE 2X	USED ON MOD. 121	PART NAME
PRINT DISTRIBUTION	CIN. GR. CON. 1	FAY. 3BL. 1BR. 3 BL.	DEQ. 3 BL.	E.P.T.	REQ. 1	PREAMP B'D. ASSEMBLY
<small>ALL DRAWINGS AND SPECIFICATIONS ARE AND REMAIN THE PROPERTY OF THE BALDWIN PIANO & ORGAN CO. AND MUST BE RETURNED TO IT. ALL SPECIFICATIONS ARE CONFIDENTIAL AND ARE NOT TO BE DISCLOSED TO ANY PERSONS OTHER THAN THOSE TO WHOM THEY ARE SENT. NO DRAWINGS, SPECIFICATIONS OR OTHER DATA BELONGING TO THE BALDWIN PIANO & ORGAN CO. WHICH MAY BE FURNISHED TO MANUFACTURERS OR OTHERS FOR ANY PURPOSE ARE TO BE REGARDED BY IMPLICATION OR OTHERWISE AS IN ANY MANNER LICENSING THE HOLDER OR ANY OTHER PERSON OR CORPORATION OR CONVEYING ANY RIGHTS OR PERMISSION TO MANUFACTURE, USE OR SELL ANY PATENTED INVENTION THAT MAY IN ANY WAY BE RELATED THERETO.</small>					FINISH ~	BMS03-121-10 GR. 9 IT.
UNLESS OTHERWISE SPECIFIED TOLERANCES ARE: DECIMAL ± .005 FRACTIONAL ± .015 ANGLE ± 1/2°					NEXT ASSEM. D003-060481	SUPERSEDES B500-060447 B
BALDWIN PIANO & ORGAN CO. CINCINNATI, OHIO					C	500-060447C

447 B.

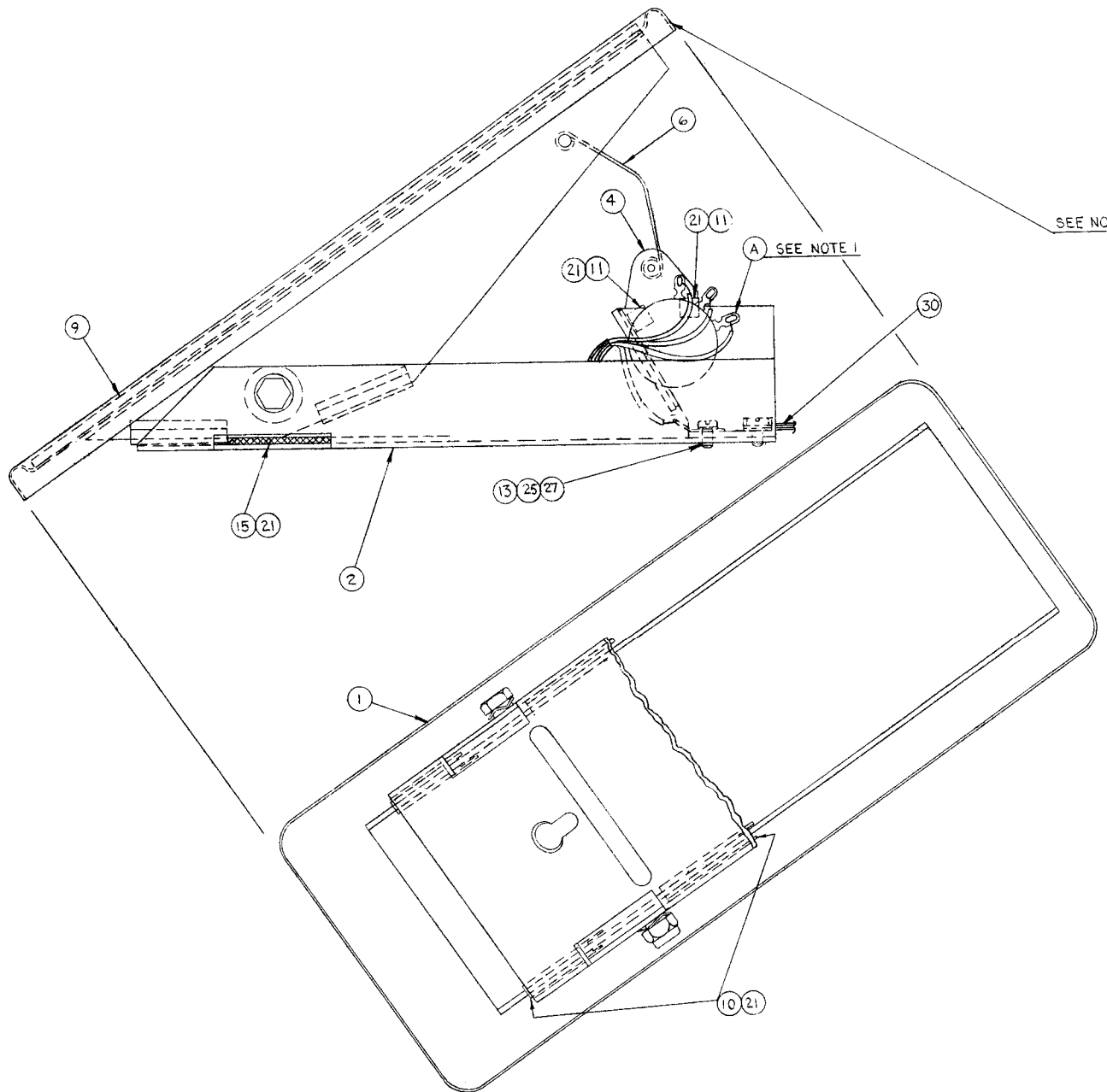

NOTES:

1. ADJUSTMENT SPECIFICATIONS - ADJUST THE POSITION OF POT. SUPPORT BRKT. (IT.3) SO THAT THE POT. LEVER (IT.4) STOPS ON THE BUSHING CLOTH (IT.14) IN BOTH EXTREMES OF TRAVEL. WITH THE SHOE FULLY UP, ROTATE THE POT. SHAFT SO THAT 50 TO 100 OHMS RESISTANCE IS MEASURED BETWEEN THE CENTER TERMINAL AND TERMINAL "A". RESISTANCE SHOULD BEGIN TO INCREASE IMMEDIATELY WITH ANY DOWNWARD MOTION OF THE SHOE. TIGHTEN THE SET SCREWS (IT.33).
2. APPLY VULCALOCK (IT.23) TO PAD (IT.9) AND LET DRY 30 MIN. TO 24 HRS. PRIOR TO CEMENTING TO PEDAL WITH BLACK ADHESIVE (IT.21) OR PLIOBOND (IT.22).
3. EXPRESSION PEDAL BUSHINGS (IT.8) ARE TO BE COVERED WITH AMPHENOL GREASE (IT.24) ON ALL BEARING SURFACES PRIOR TO ASSEMBLY.
4. ADJUST FOR DOWN PRESSURE OF 400 GRAMS.

RELEASED

Ord. No. R.N. 597
Date 8-5-71

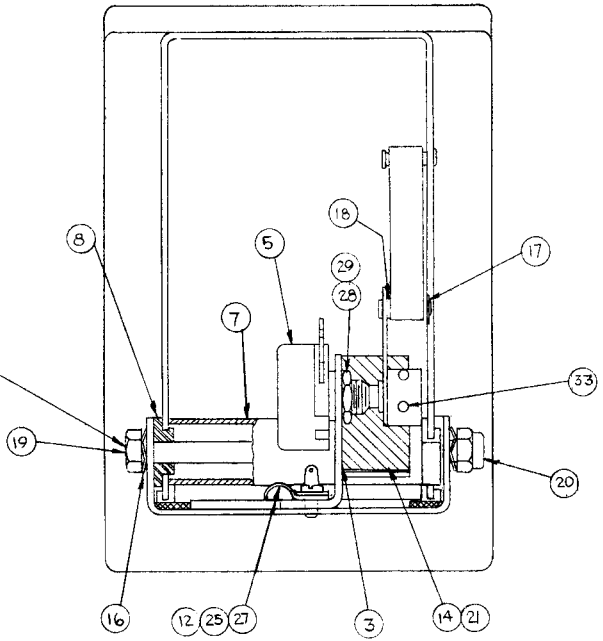

33	2	S2115-8-32-3	SET SCREW, #8-32 3/16 LG
32	X	S134-4	SOLDER
31	X	S2294-16	TAPE, BLACK PAPER 1/2 W. (NOT SHOWN)
30	1	B508-053443	EXP PED CABLE - EXP PED END
29	1	A247-015158	NUT, 3/8-32 HEX.
28	1	S125-10 SCPL	LOCKWASHER, 3/8 I.T.
27	2	S2022-3 SCPL	FLAT WASHER #6
26			
25		S2093-6-32-4 SCPL	SCREW, #6-32 PAN HD. SEMS 1/4 LG.
24	X	A249-016587	AMPHENOL GREASE 53-307
23	X	A249-012186	VULCALOCK
22	X	A249-018019	PLIOBOND #30
21	X	A249-022737	CEMENT - BLACK
20	1	A247-022975	ELASTIC STOP NUT
19		A247-025225	SCREW, 1/4-28 H.H. SPECIAL 3 3/8 LG.
18	2	A244-036416	NYLON SHIM
17	1	A247-031746	"E" RING
16	4	A247-040149	SPRING WASHER
15	2 PCS.	A244-000055	BUSHING CLOTH ⁰⁵³ / ₀₅₀ , 3/4 x 4" LG.
14	1 PC.	A244-000055	BUSHING CLOTH ⁰⁵⁸ / ₀₅₀ , 3/4 x 1 1/2 LG.
13	1	A516-000011	SOLDER LUG
12	1	A237-10025-1	CABLE CLAMP
11	1/2"	A244-028468	RUBBER CHANNEL (2 PCS. 1/4" LG)
10	5"	A525-034469	VINYL EXTRUSION (4 PCS. 1 1/4" LG)
9	1	C244-022513	PAD, EXPRESSION PEDAL
8	2	A244-026736	BUSHING
7	1	A237-033321	EXPRESSION PEDAL SPACER
6	1	A526-035985	DRIVE SPRING
5	1	B509-048890	POTENTIOMETER, 50K 180° LIN. TAPER
4	1	A500-044740	POT. LEVER RIVETED ASSY.
3	1	B528-044743	POT. SUPPORT BRKT.
2	1	C528-043144	EXP. PED. CHANNEL
1	1	C500-046637	PEDAL RIV. ASSY

ITEM	REQ	PART NO.	PART NAME
------	-----	----------	-----------

RECORD OF CHANGE

PART DISTRIBUTION				DATE <i>Hoffman</i>		PART NAME	
B.V.	D.E.G.	BOUL.	B.B.L.	DATE	EXP. PEDAL ASSY.		
	382			JUNE 24 1971			
D.H.L.	DR.	CON.	FAY	CHKD BY	S/W 563-124-12 (1) IT.		
				<i>HEK</i>	ORGAN MOD 124 A		
FILE	382-124			APPR.	R003-053562		
ALL DRAWINGS AND SPECIFICATIONS ARE AND REMAIN THE PROPERTY OF THE D. H. BALDWIN COMPANY AND MUST BE RETURNED TO IT. ALL SPECIFICATIONS ARE CONFIDENTIAL AND ARE NOT TO BE DISCLOSED TO ANY PERSONS OTHER THAN THOSE TO WHOM THEY ARE SENT. NO DRAWINGS, SPECIFICATIONS OR OTHER DATA BELONGING TO THE D. H. BALDWIN COMPANY WHICH MAY BE FURNISHED TO MANUFACTURERS OR OTHERS FOR ANY PURPOSE ARE TO BE REGARDED BY IMPLICATION OR OTHERWISE AS IN ANY MANNER LICENSING THE HOLDER OR ANY OTHER PERSONS OF OR CONFERRING ANY RIGHTS OR PERMISSION TO MANUFACTURE, USE OR SELL ANY PATENTED INVENTION THAT MAY IN ANY WAY BE RELATED THEREOF.				FINISH		SUPERSEDES	
UNLESS OTHERWISE SPECIFIED TOLERANCES ARE:				DECIMAL ± .008		ANGLE ± 14°	
				FRACTIONAL ± .015			
				D. H. BALDWIN CO.		D 500-053250 A	
				CINCINNATI, OHIO			

POWER SUPPLY DESCRIPTION

Reference: Power Supply Schematic - D501-060598
Power Supply, Amp., AC &
DC Wiring Diagram - D501-060689
Figures - 4 & 14

The Model 121 series organs utilize one Power Supply, producing all the necessary operating voltages for the organ circuitry. The Power Supply is protected against overload by a 2 ampere, slo-blo fuse in the primary of the power transformer.

The center-tapped secondary winding of the power transformer (yellow-red/yellow-yellow) is rectified by a pair of diodes, D1 and D2, and filtered by capacitor C1, providing the -18 volt supply. This supply is dropped and filtered further by R1, C2 and R2 to provide the -9.0 V.D.C. source supply for the tone generator assembly.

The same winding is also rectified by diodes D5 and D6 and filtered by capacitor C3 to provide the positive +18V source supply, which is used as the primary voltage for +9V and +5V regulated supply circuits.

The red-red/yellow-red winding is rectified by D3 and D4 and filtered by capacitor C8 to provide +53 V.D.C. source supply, which is used as the primary voltage for +27V and +14V regulated supply circuits and as the supply source for the power amplifier output stage. C8 capacitor is located on the treble end of the console near the power transformer.

A series regulated circuit is used to provide the +9 V.D.C. source for the tone generator circuits. The output voltage (+9 V.D.C.) is sensed by R7 and applied to Q3, a reference amplifier. The emitter voltage of Q3 is set by D8, an 8.2V zener diode, and remains constant. The voltage across R9 will remain constant due to zener action of emitter-base junction of Q3 and will be set to about $8.2 + 0.6 = 8.8V$. Therefore, any voltage change of the +9V supply will be sensed by R7 which will cause Q3 to draw more or less current, varying the conduction of Q2 and Q1, the series regulating element.

For example, if the output current increases, the output voltage will drop, causing less voltage across R7 with a corresponding decrease in the current through Q3. R8 provides the collector current for Q3 and the base current for Q2. Due to the decrease in the conduction of Q3, more current will be supplied to Q2, which will now conduct harder, and then cause Q1 to also conduct harder. Saturation resistance of Q1 will be lowered (series resistance between +18V and +9V) and the +9V will come up to its nominal regulated voltage value.

Q1 transistor operates as a variable resistor (rheostat), Q3 transistor senses the current requirement for the output circuit and with the aid of Q2 current, the amplifier changes the setting to the rheostat (Q1 transistor).

To assure that the power supply provides good regulation, the +9V source lead and the reference lead on the board assembly are separately brought out and connected together closer to the load.

Diode D7, connected from the +27V regulated supply output, assures that the +9V regulator circuit will not fail to start operating, because of the constant load of tone generator circuit, when the console power is switched on.

Resistors R3 and R4 are the current limiters (protectors) for the series regulator transistor Q2 and Q1. The resistors, at the same high current (well above normal), take voltage away from the series transistors to prevent excessive thermal dissipation. The regulator is "short proof" and will deliver the same maximum current at zero volts output.

The operation of +27 volts regulated supply is identical to that of the +9 V.D.C. regulated supply and consists of Q4 (series regulator), Q5 (driver) and Q6 (reference D.C. amplifier). The reference voltage for this regulator is the +9 V.D.C. regulated source, applied to the emitter of Q6 transistor via blocking diode D9. Output voltage of this regulator is factory preadjusted by selection of the R16 resistor.

On the preamplifier board assembly the +27 V.D.C. source is stepped down and filtered by R22 and C18 to +22 V.D.C. for the various organ circuits.

The regulator circuit for +5 V.D.C. is basically the same as previously described circuit for +9 V.D.C. with the exception that the reference circuit for this supply uses differential amplifier configuration of Q8 and Q9, operating from the +9 V.D.C. supply.

The +14 V.D.C. source is derived from the +53 V.D.C. and +27 V.D.C. regulated supply. The +53 V.D.C. provides the current for the load via R20, R21 and Q7 and is additionally filtered by C13. The +27 V.D.C. regulated source via resistor dividers R19, R22 and R23, is used as the voltage reference for the base circuit of Q7. Resistor R23 is factory selected to obtain +14 V.D.C. source.

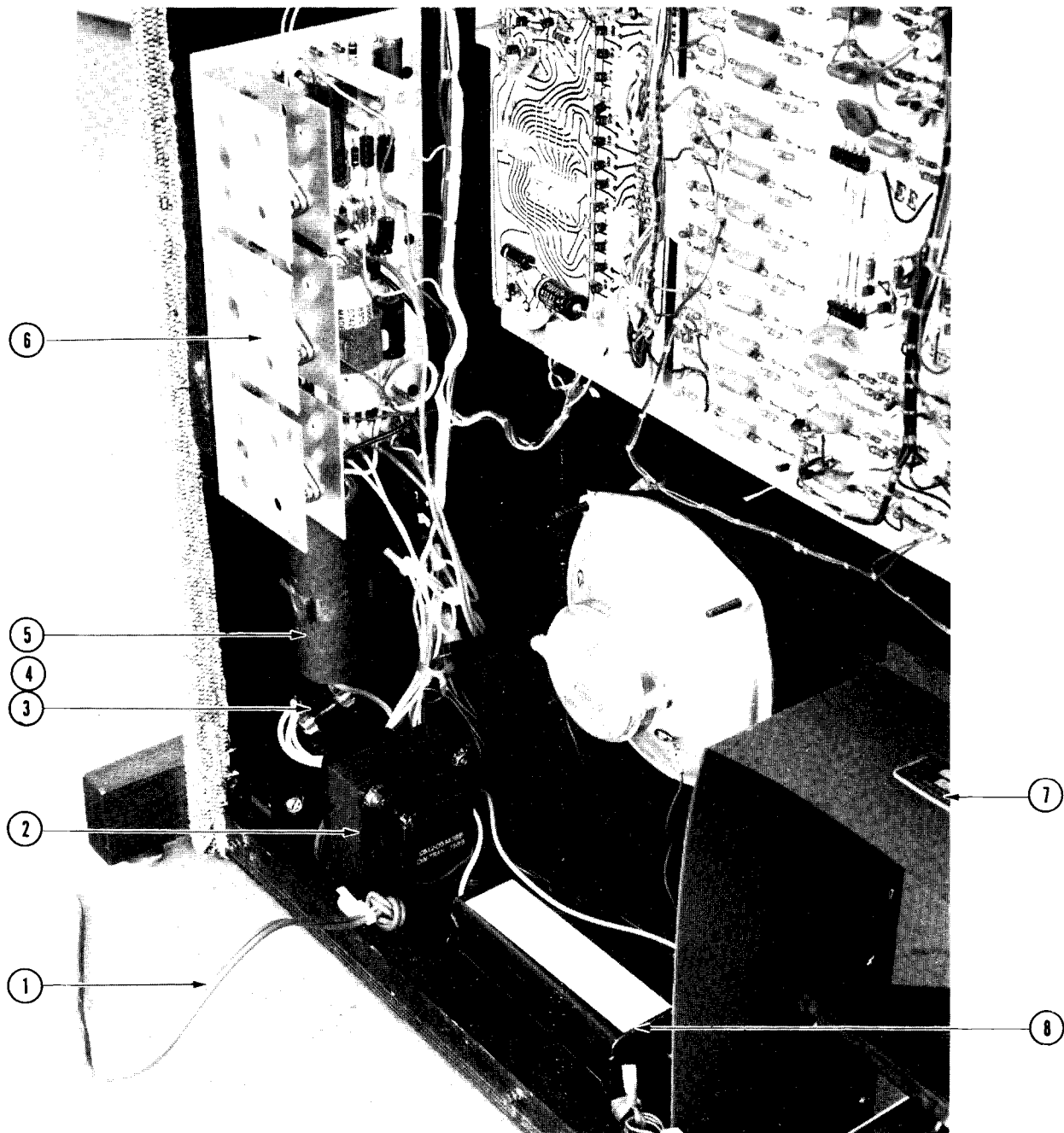
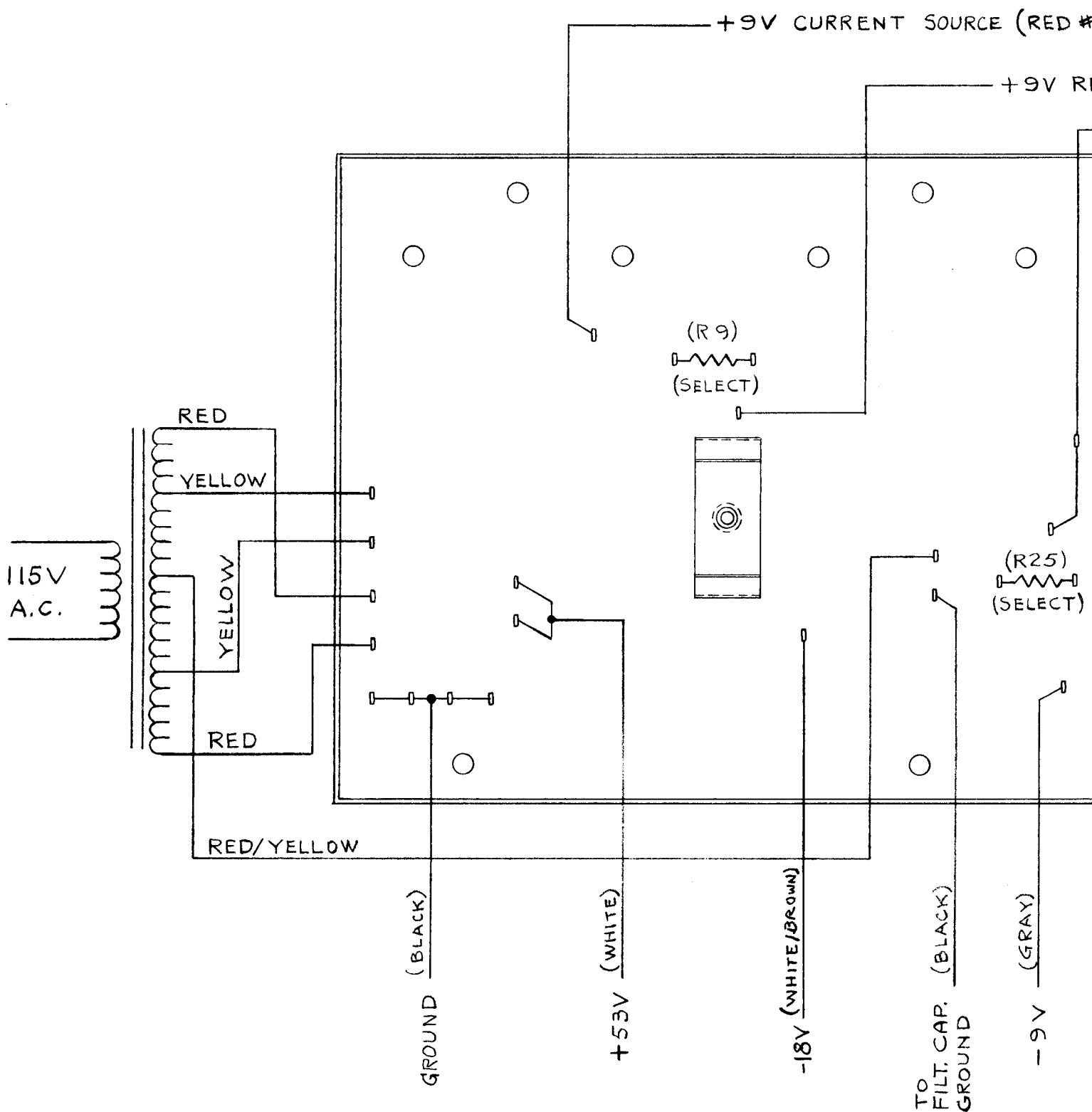

FIG. 14 - POWER SUPPLY VIEW

ITEM	DESCRIPTION	PART NUMBER
1	POWER CORD	B508-027658
2	POWER TRANSFORMER	C512-053438
3	FUSEHOLDER	A514-059976
4	SLOW BLOW FUSE, 2 AMP,	A514-032101
5	CAPACITOR 4000 MFD/60V	B517-038985
6	POWER SUPPLY BOARD ASSEMBLY	C500-060603
7	NAMEPLATE - SERIAL NUMBER	A249-044970
8	BALLAST - FLUORESCENT LAMP - 115V 60 Hz	B514-060522



DATE	1-7-74	DWN.	ROBERTS	C
PRINT	CIN.	GR.	CON	
DISTRIBUTION	S			

ALL DRAWINGS AND SPECIFICATIONS ARE AND REMAIN RETURNED TO IT. ALL SPECIFICATIONS ARE CONFIDENTIAL TO WHOM THEY ARE SENT. NO DRAWINGS, SPECIFICATION WHICH MAY BE FURNISHED TO MANUFACTURERS OR OTI OTHERWISE AS IN ANY MANNER LICENSING THE HOLDER C OR PERMISSION TO MANUFACTURE, USE OR SELL ANY P

UNLESS OTHERWISE SPECIFIED TOLERANCES

E (RED #1)

+9V REG. (RED #2)

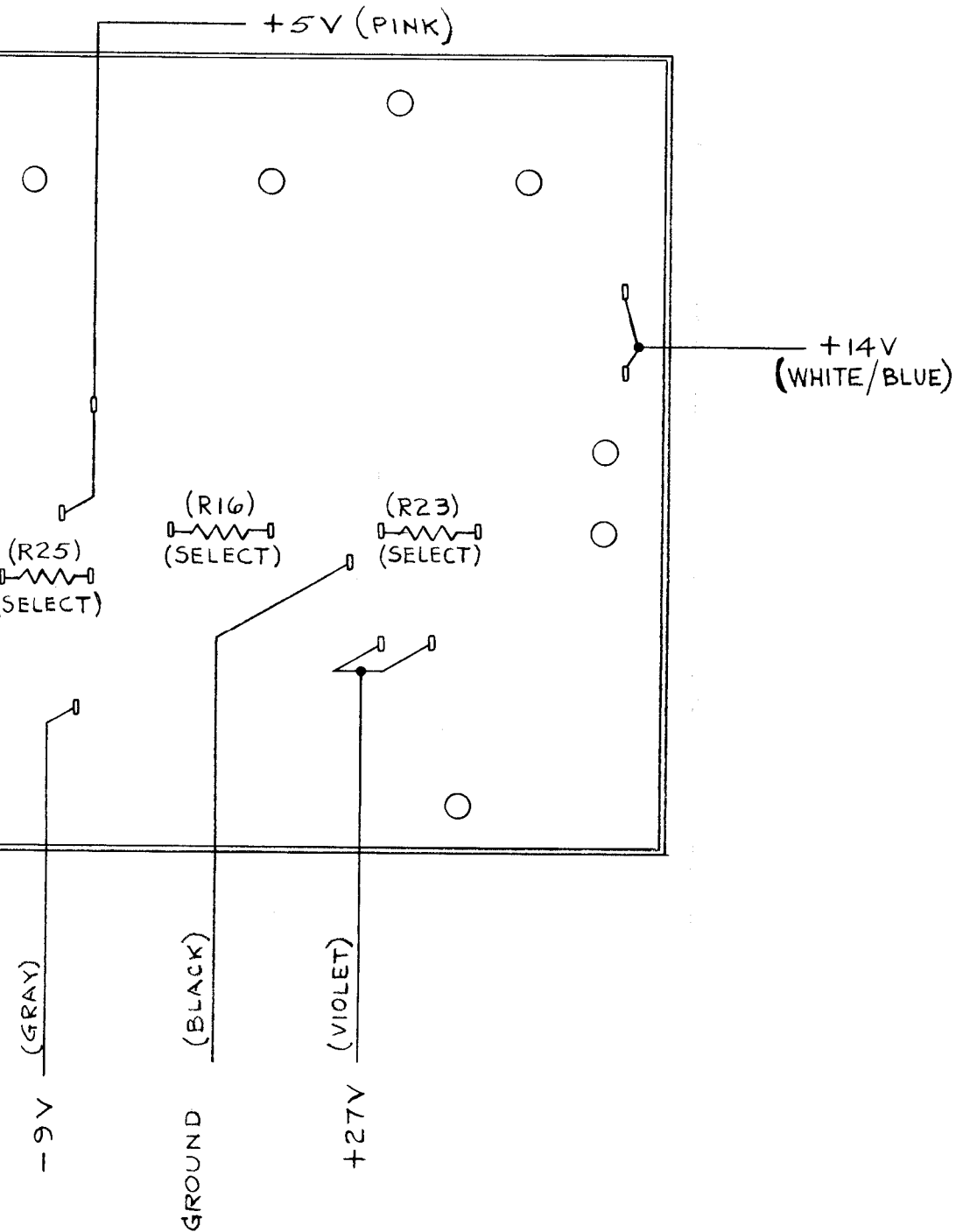

RELEASED

Ord. No. R.N. 650
Date 11/6/74

RECORD OF CHANGE

A) ADDED -18V SOURCE TERM.
C.N. 16,344 G-11-75 PJ

MICRO FILMED BY TS

CH'D. <i>Dml</i>	APP'D. <i>Rak.</i>	DWN.SCALE FULL	USED ON MOD.121	PART NAME POWER SUPPLY B'D. PIN WIRING DIAGRAM	
CON.	FAY. X	DEQ. X	REQ. -	B/M 503-121-10 GR. NOTE IT.	
<small>THIS DRAWING IS THE PROPERTY OF THE BALDWIN PIANO & ORGAN CO. AND MUST BE KEPT CONFIDENTIAL AND ARE NOT TO BE DISCLOSED TO ANY PERSONS OTHER THAN THOSE SPECIFIED. SPECIFICATIONS OR OTHER DATA BELONGING TO THE BALDWIN PIANO & ORGAN CO. OR OTHERS FOR ANY PURPOSE ARE TO BE REGARDED BY IMPLICATION OR OTHERWISE AS THE PROPERTY OF THE BALDWIN PIANO & ORGAN CO. NO RIGHTS ARE TO BE GRANTED BY THIS DRAWING TO ANY OTHER PERSON OR CORPORATION OR CONVEYING ANY RIGHTS OR SELL ANY PATENTED INVENTION THAT MAY IN ANY WAY BE RELATED THERETO.</small>			NEXT ASSEM. ~	SUPERSEDES	
TOLERANCES ARE: DECIMAL ± .005 FRACTIONAL ± .015 ANGLE ± 1/2°			BALDWIN PIANO & ORGAN CO. CINCINNATI, OHIO		REV. B 501-060604 A

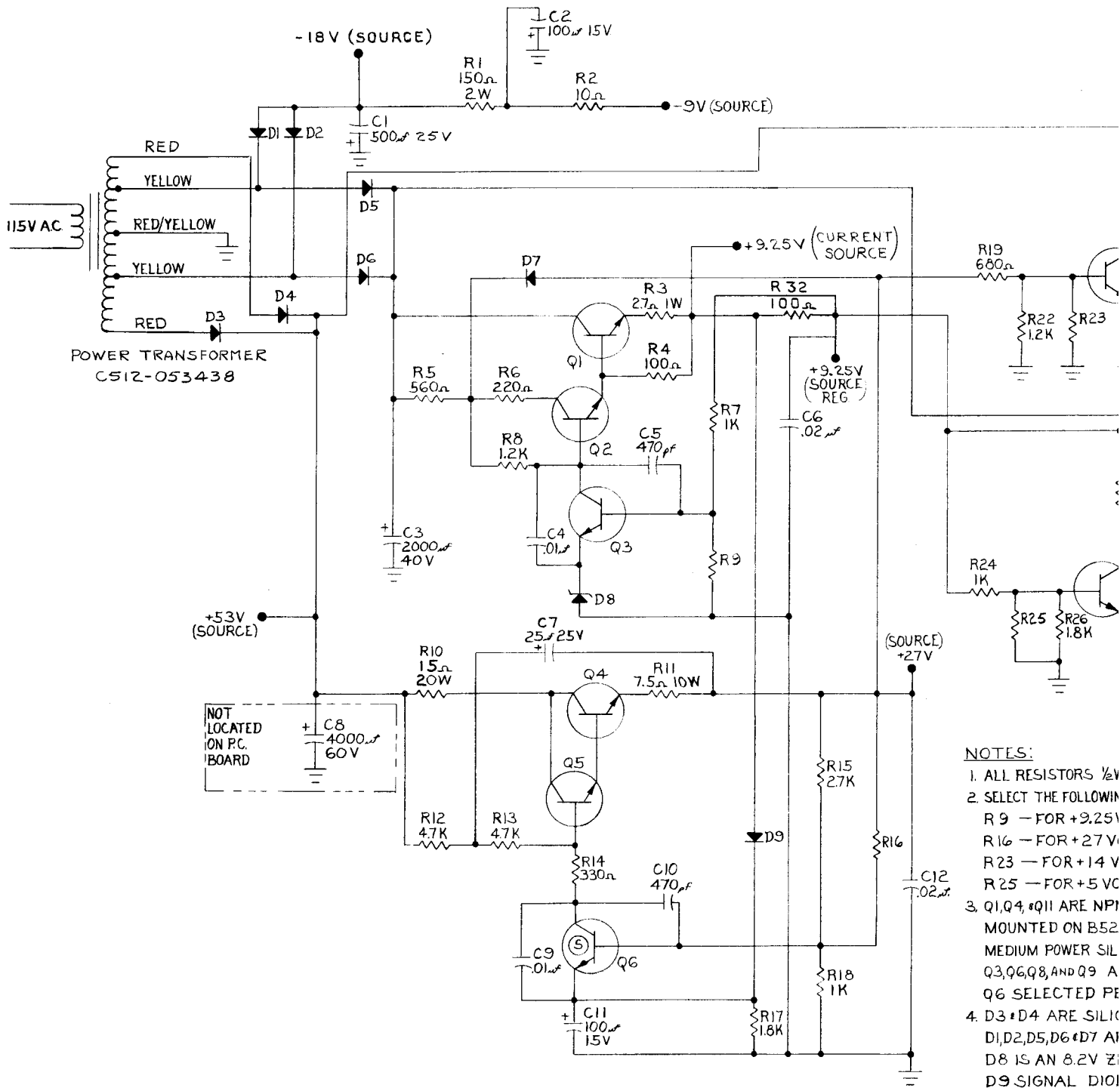

NOTES:

1. ALL RESISTORS 1/2W
2. SELECT THE FOLLOWING
R 9 - FOR +9.25V
R 16 - FOR +27V
R 23 - FOR +14V
R 25 - FOR +5V
3. Q1, Q4, & Q11 ARE NPN MOUNTED ON B52 MEDIUM POWER SIL
Q3, Q6, Q8, AND Q9 ARE PNP
Q6 SELECTED PER
4. D3 & D4 ARE SILICON
D1, D2, D5, D6 & D7 ARE
D8 IS AN 8.2V ZENER
D9 SIGNAL DIODE

DATE 12-27-73 DWN: J.E. Johnson

PRINT	CIN.	GR.	C
DISTRIBUTION	5		

LAST COMP. NO. USED

C	R	D	Q
18	32	9	11

ALL DRAWINGS AND SPECIFICATIONS ARE AND REMAINED THE PROPERTY OF THE COMPANY TO WHOM THEY ARE SENT. NO DRAWINGS, SPECIFICATIONS OR PARTS LIST ARE TO BE REPRODUCED OR OTHERWISE AS IN ANY MANNER LICENSING THE HOLD OR PERMISSION TO MANUFACTURE, USE OR SELL ANY PARTS THEREOF.

UNLESS OTHERWISE SPECIFIED TOLERANCES ARE AS SHOWN

-9V (SOURCE)

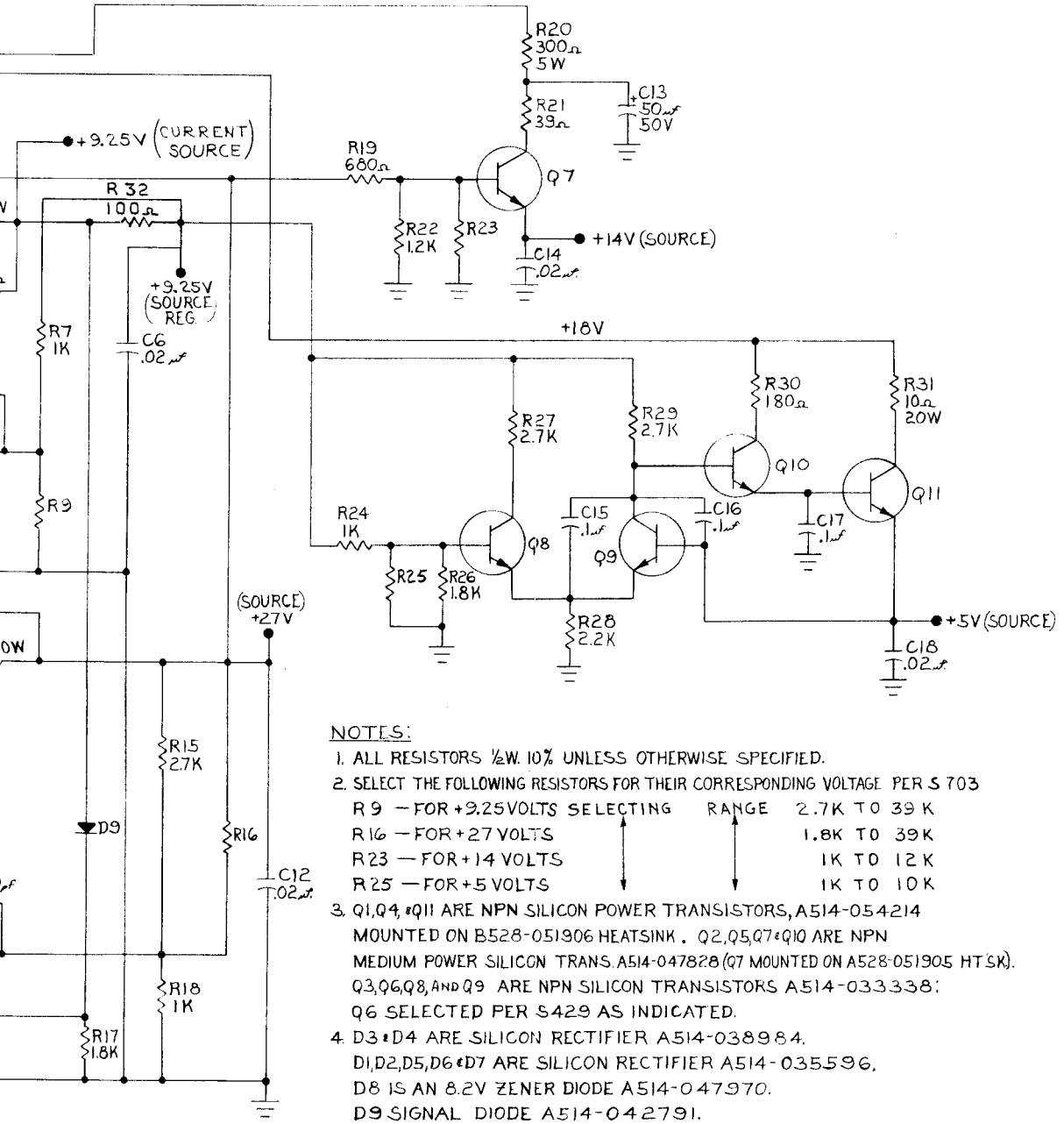

- NOTES:**
1. ALL RESISTORS 1/2W. 10% UNLESS OTHERWISE SPECIFIED.
 2. SELECT THE FOLLOWING RESISTORS FOR THEIR CORRESPONDING VOLTAGE PER S 703

R9 - FOR +9.25 VOLTS SELECTING RANGE	2.7K TO 39K
R16 - FOR +27 VOLTS	1.8K TO 39K
R23 - FOR +14 VOLTS	1K TO 12K
R25 - FOR +5 VOLTS	1K TO 10K
 3. Q1, Q4, & Q11 ARE NPN SILICON POWER TRANSISTORS, A514-054214 MOUNTED ON B528-051906 HEATSINK. Q2, Q5, Q7 & Q10 ARE NPN MEDIUM POWER SILICON TRANS A514-047828 (Q7 MOUNTED ON A528-051905 HTSK). Q3, Q6, Q8, AND Q9 ARE NPN SILICON TRANSISTORS A514-033338; Q6 SELECTED PER S429 AS INDICATED.
 4. D3 & D4 ARE SILICON RECTIFIER A514-038984. D1, D2, D5, D6 & D7 ARE SILICON RECTIFIER A514-035596. D8 IS AN 8.2V ZENER DIODE A514-047970. D9 SIGNAL DIODE A514-042791.

RELEASED

Ord. No. R.N. 650
Date 1/15/74

RECORD OF CHANGE

(A) +9.25V WAS +9V
C.N. 16, 270 5-20-75 D.G.

(B) R11 WAS 5W RESISTOR
ADDED R32 & -18V
(SOURCE). D. D.
C.N. 16, 344 6-11-75

DATE 12-27-73		DWN. <i>J.E. Johnson</i>		CH'D. <i>J.J.</i>	APP'D. <i>Rak</i>	DWN SCALE	USED ON 127, 128, 121	PART NAME POWER SUPPLY SCHEMATIC		
PRINT	CIN.	GR.	CON.	FAY.	DEQ.	E. P. T.	REQ.			
DISTRIBUTION	5			5BL-1BR	SBL.		FINISH	B/M 503-121-10	GR. NOTE IT.	
ALL DRAWINGS AND SPECIFICATIONS ARE AND REMAIN THE PROPERTY OF THE BALDWIN PIANO & ORGAN CO. AND MUST BE RETURNED TO IT. ALL SPECIFICATIONS ARE CONFIDENTIAL AND ARE NOT TO BE DISCLOSED TO ANY PERSONS OTHER THAN THOSE TO WHOM THEY ARE SENT. NO DRAWINGS, SPECIFICATIONS OR OTHER DATA BELONGING TO THE BALDWIN PIANO & ORGAN CO. WHICH MAY BE FURNISHED TO MANUFACTURERS OR OTHERS FOR ANY PURPOSE ARE TO BE REGARDED BY IMPLICATION OR OTHERWISE AS IN ANY MANNER LICENSING THE HOLDER OR ANY OTHER PERSON OR CORPORATION OR CONVEYING ANY RIGHTS OR PERMISSION TO MANUFACTURE, USE OR SELL ANY PATENTED INVENTION THAT MAY IN ANY WAY BE RELATED THERETO.							NEXT ASSEM.		SUPERSEDES	
UNLESS OTHERWISE SPECIFIED TOLERANCES ARE: DECIMAL ±.005 FRACTIONAL ±.015 ANGLE ±.12°							BALDWIN PIANO & ORGAN CO. CINCINNATI, OHIO		C 501-060598	REV. B

LAST COMP. NO. USED			
C	R	D	Q
18	32	9	11

NOTES:

- 1) TRANSISTORS Q1, Q11 & Q4 ARE NPN SILICON POWER TRANSISTORS AS14-059214 (IT. 34) MOUNTED ON HEATSINK B528-051906 (IT. 40). TRANSISTORS Q2, Q10, Q5 & Q7 ARE NPN MEDIUM POWER SILICON TRANSISTORS AS14-047828 (IT. 33) WITH Q7 MOUNTED ON HEATSINK AS28-051905 (IT. 39). TRANSISTORS Q3, Q6, Q8 & Q9 ARE NPN SILICON TRANSISTORS AS14-033338 (IT. 32) WITH Q6 SELECTED PER S429-2.
- 2) THESE RESISTORS TO BE SELECTED AS FOLLOWS:
 R9 FOR +3 VOLTS (RANGE 2.7K TO 39K)
 R16 FOR +27 VOLTS (RANGE 1.8K TO 39K)
 R23 FOR +14 VOLTS (RANGE 1K TO 12K)
 R25 FOR +5 VOLTS (RANGE 1K TO 10K)
- 3) D1, D2, D5, D6, & D7 ARE SILICON RECTIFIERS AS14-035526 (IT. 37). D3 & D4 ARE SILICON RECTIFIERS AS14-038984 (IT. 38). D8 IS A ZENER 8.2V DIODE AS14-047870 (IT. 35). D9 IS A MEDIUM VOLTAGE, SIGNAL DIODE AS14-042791 (IT. 36).
- 4) REFERENCE SCHEMATIC 0501-060598.
 REFERENCE PIN WIRING DIAGRAM 8501-060604.
- 5) FINAL ASSEMBLY MUST INCLUDE LABEL MARKED 500-060603 A.

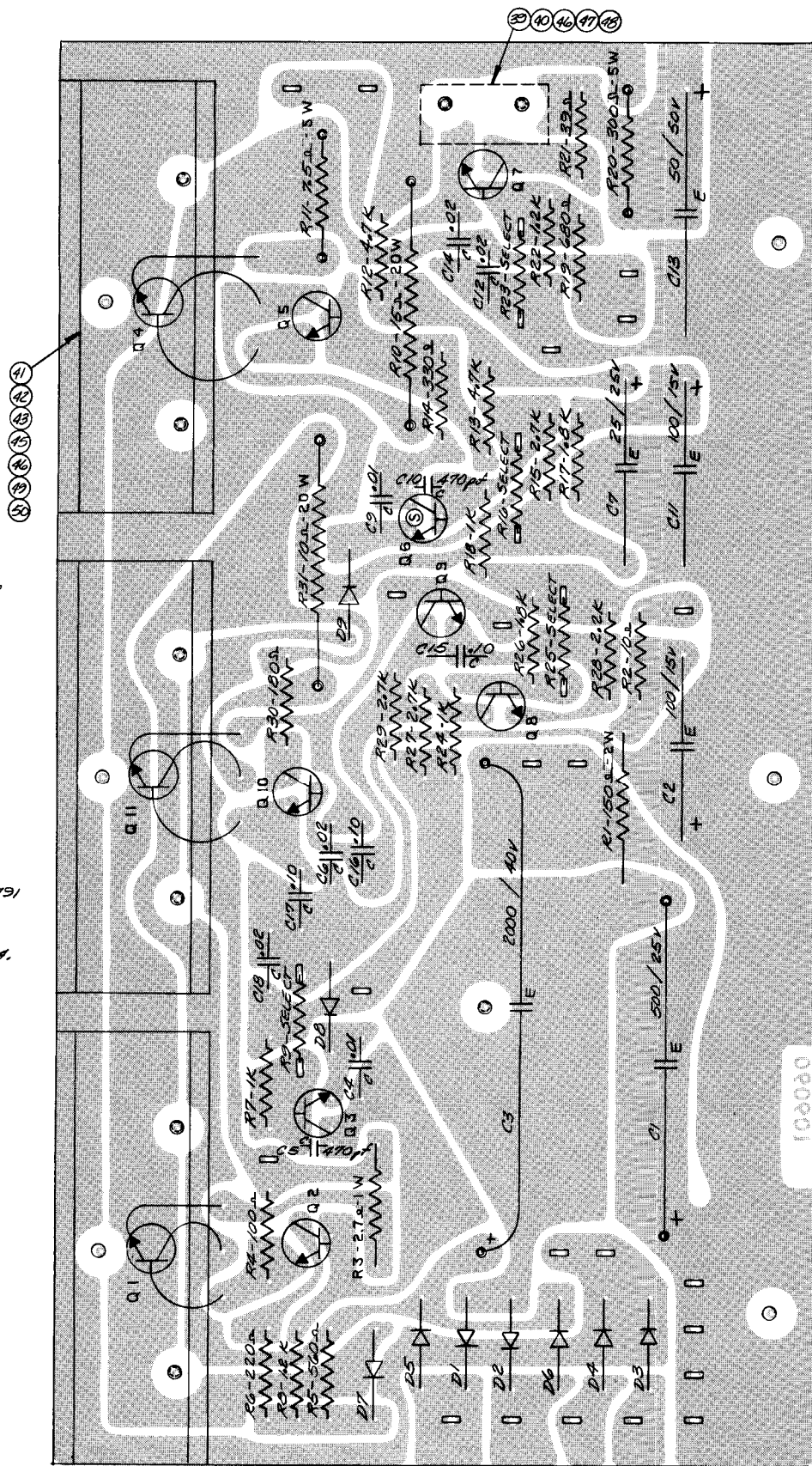

100000

LEGEND:
 "C" DENOTES CERAMIC CAPACITOR
 "E" DENOTES ELECTROLYTIC CAPACITOR

RELEASED
 Ord. No. R.H. 650
 Date 1116 174

RECORD OF CHANGE

Ⓐ 17, 22 WAS
 S240-250-20, 25Ω
 20 W RESISTOR.
 C.N 15716 H.C.R. 2-4-74

Ⓑ REDRAW, NO CHG.
 K.M.B 8-29-74

Ⓒ REDRAWN 2 X SIZE
 NO CHANGE, NO C.N.
 K.M.B 9-16-74

52	X	S184-3	SOLDER - DIP
51	X	S134-4	SOLDER - IRON
50	X	S224-	WIRE #22 SOLID
49	X	A849-016587	SILICON COMPOUND
48	1	S2252-1 SCPL	NUT #4-40 KEPS
47	1	S2040-4-40-B SCR	SCR #4-40 R.H. MACH. 1/2 LG.
46	8	S2267-6-4 BL. OX	SCR #6 R.H. TYPE "17" 1/2 LG.
45	6	S2276-8 SCPL	SCR #6 R.H. TYPE "A" 1/2 LG.
44	1	A244-047902	SPACER
43	3	A514-033359	INSULATOR MICA
42	3	B507-033322	TRANSISTOR SOCKET
41	6	A244-047994	SHOULDER WASHER
40	3	B528-051906	HEATSINK
39	1	A528-051905	HEATSINK
38	2	A514-038984	RECTIFIER SILICON
37	5	-035596	RECTIFIER SILICON
36	1	-042791	DIODE SIGNAL (MED. VOLTAGE)
35	1	-047970	DIODE ZENER 5.2 V
34	3	-054214	TRANSISTOR NPN SILICON POWER
33	4	-047828	TRANSISTOR NPN MEDIUM POWER
32	4	A514-033338	TRANSISTOR NPN SILICON
31	1	A517-051652	CAPACITOR ELECT. 2000μF 40V
30	1	S211-025-500	ELECT. 500μF 25V
29	2	S211-015-100	ELECT. 100μF 15V
28	1	S211-050-050	ELECT. 50μF 50V
27	1	S211-025-025	ELECT. 25μF 25V
26	3	S218-104	CER. .1μF
25	4	S205-203	CER. .02μF
24	2	S205-103	CER. .01μF
23	2	S205-471	CAPACITOR CER. 470μF
22	1	S240-150-20	RESISTOR 20W 15Ω
21	1	S240-100-20	20W 10Ω
20	1	S240-301-05	5W 300Ω
19	1	S240-745-05	5W 7.5Ω
18	1	S121-15	2W 150Ω
17	1	S117-64	1W 27Ω
16	2	S239-472	1/2W 10% 47K
15	3	272	2.7K
14	1	222	2.2K
13	2	182	1.8K
12	2	122	1.2K
11	3	102	1K
10	1	681	680Ω
9	1	561	560Ω
8	1	331	330Ω
7	1	221	220Ω
6	1	181	180Ω
5	1	101	100Ω
4	1	390	39Ω
3	1	100	10Ω
2	4	S239-566ECT	RESISTOR 1/2W 10% SEL.
1	1	B505-060602	POWER SUPPLY B'D RV.

DATE	9-16-74	DRN	BRADY	CHK	2-11-74	APPD.	Dub	DYNSCALE	2X	USED ON	1/21	PART NAME	POWER SUPPLY B'D ASSEM.
PRINT	FILE	OR.	OR.	PAY.	DEB.	E.P.T.	FINISH	~	RM	503-121-100A	IT.		
<small>ALL DIMENSIONS AND SPECIFICATIONS ARE AND REMAIN THE PROPERTY OF THE BALDWIN PIANO & ORGAN CO. AND MUST BE OBTAINED FROM IT. ALL INFORMATION IS CONFIDENTIAL AND NOT TO BE DISCLOSED TO ANY PERSON OTHER THAN THOSE TO WHOM IT IS ISSUED. NO DIMENSIONS OR OTHER DATA BELONGING TO THE BALDWIN PIANO & ORGAN CO. SHOULD BE REPRODUCED OR TRANSMITTED IN ANY FORM OR BY ANY MEANS, ELECTRONIC OR MECHANICAL, INCLUDING PHOTOCOPYING, RECORDING, OR BY ANY INFORMATION STORAGE AND RETRIEVAL SYSTEM. THIS DOCUMENT IS THE PROPERTY OF BALDWIN PIANO & ORGAN CO. AND IS TO BE KEPT IN STRICTLY CONFIDENTIAL. ANY DISCLOSURE OF THIS DOCUMENT TO ANY OTHER PERSON OR ENTITY WITHOUT THE WRITTEN PERMISSION OF BALDWIN PIANO & ORGAN CO. IS STRICTLY PROHIBITED. BALDWIN PIANO & ORGAN CO. IS NOT RESPONSIBLE FOR ANY DAMAGE TO PERSONS OR PROPERTY CAUSED BY THE USE OF THIS DOCUMENT.</small>												NEXT ASSEM. D203-060481 SUPERSEDES C500-060605	
UNLESS OTHERWISE SPECIFIED TOLERANCES ARE DECIMAL 2.00 FRACTIONAL 2.00 ANGLES 2.14°												BALDWIN PIANO & ORGAN CO. CINCINNATI, OHIO	D 500-060603 C

41
42
43
44
45
46
47
48

49
50
51
52

NOTES:

- 1) TRANSISTORS Q1, Q11 & Q4 ARE NPN SILICON POWER TRANSISTORS AS14-054214 (IT. 34) MOUNTED ON HEATSINK B528-051906 (IT. 40). TRANSISTORS Q2, Q10, Q5 & Q7 ARE NPN MEDIUM POWER SILICON TRANSISTORS AS14-047823 (IT. 33) WITH Q7 MOUNTED ON HEATSINK A528-051905 (IT. 39). TRANSISTORS Q3, Q6, Q8 & Q9 ARE NPN SILICON TRANSISTORS AS14-033338 (IT. 32) WITH Q6 SELECTED PER 5429-2.
- 2) THESE RESISTORS TO BE SELECTED AS FOLLOWS:
 R9 FOR +125 VOLTS (RANGE 2.7K TO 39K)
 R16 FOR +27 VOLTS (RANGE 1.8K TO 39K)
 R23 FOR +14 VOLTS (RANGE 1K TO 12K)
 R26 FOR +5 VOLTS (RANGE 1K TO 10K)
- 3) D1, D2, D5, D6, & D7 ARE SILICON RECTIFIERS AS14-035526 (IT. 37). D3 & D4 ARE SILICON RECTIFIERS AS14-038984 (IT. 38). D8 IS A ZENER 8.2V DIODE AS14-047970 (IT. 35). D9 IS A MEDIUM VOLTAGE, SIGNAL DIODE AS14-042791 (IT. 36).
- 4) REFERENCE SCHEMATIC 0501-060598, REFERENCE PIN WIRING DIAGRAM B501-060604.
- 5) FINAL ASSEMBLY MUST INCLUDE LABEL MARKED 500-060603 A

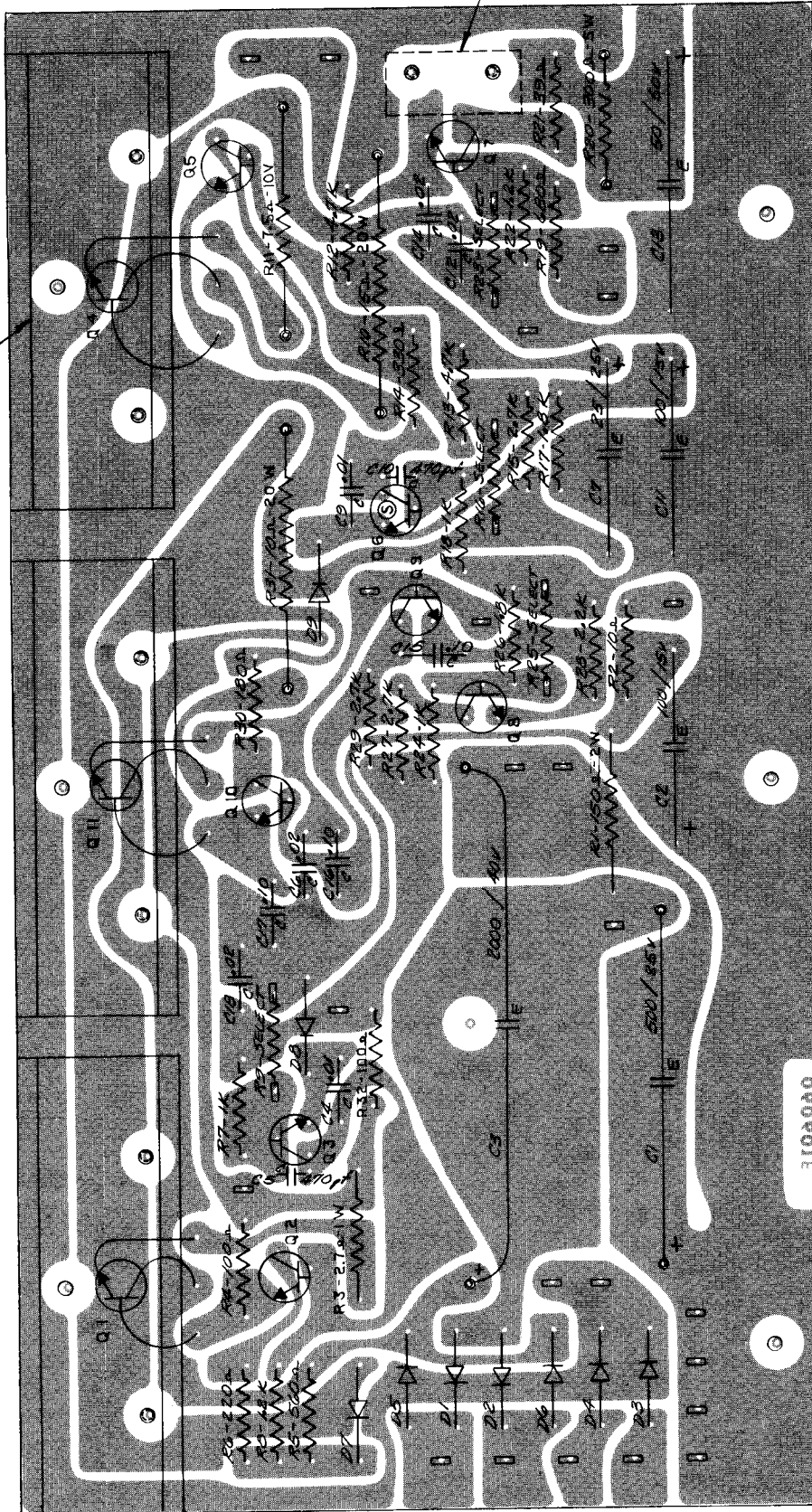

LEGEND:

"C" DENOTES CERAMIC CAPACITOR
 "E" DENOTES ELECTROLYTIC CAPACITOR

RELEASED
 Ord. No. R.N. 650
 Date 1116 174

RECORD OF CHANGE

① IT. 22 WAS
 S240-250-20, 25 Ω
 20 W RESISTOR.
 CN 15716 H.C.R. 2-4-74

② REDRAW, NO CH'G,
 LMB 8-27-74

③ REDRAWN 2 X SIZE
 NO CHANGE, NO CN.
 KMB 9-16-74

④ +9.25V WAS +9V.
 C.N. 16,270 S-20-73 D.D.

⑤ IT. 19 WAS 5W RESISTOR
 RELOCATED Q5.
 CN 16,344 D.D. 6-11-75

⑥ ADDED ITEM 53
 CN 16,634 4-21-76 DP.

53	X	A249-100021	GLUE, HOT MELT
52	X	S184-3	SOLDER - DIP
51	X	S184-4	SOLDER - IRON
50	X	S224-	WIRE #22 SOLID
49	X	A249-016587	SILICON COMPOUND
48	I	S2262-1 SCAL	NUT #4-40 KEPS
47	I	S2040-4-40-B30R	SCR. #4-40 R.H. MAGN. 1/2 LG.
46	B	S22276-4 B.L.O.	SCR. #6 R.H. TYPE 7" 1/2 LG.
45	G	S22276-B SCAL	SCR. #6 R.H. TYPE 7" 1/2 LG.
44	I	A244-047992	SPACER
43	3	AS14-033359	INSULATOR NICA
42	3	B507-033322	TRANSISTOR SOCKET
41	G	A244-047994	SHOULDER WASHER
40	3	B528-061906	HEATSINK
39	1	A528-061905	HEATSINK
38	2	AS14-033384	RECTIFIER SILICON
37	5	-035596	RECTIFIER SILICON
36	1	-042791	DIODE SIGNAL (MED. VOLTAGE)
35	1	-047970	DIODE ZENER 8.2 V
34	3	-054214	TRANSISTOR NPN SILICON POWER
33	4	-047828	TRANSISTOR NPN MEDIUM POWER
32	4	AS14-033338	TRANSISTOR NPN SILICON
31	1	AS17-051652	CAPACITOR ELECT. 2000 μF 40V
30	1	S211-025-600	ELECT. 500 μF 25V
29	2	S211-015-100	ELECT. 100 μF 15V
28	1	S211-050-050	ELECT. 50 μF 50V
27	1	S211-025-025	ELECT. 25 μF 25V
26	3	S218-104	CER. .1 μF
25	4	S205-203	CER. .02 μF
24	2	S205-103	CER. .01 μF
23	2	S205-471	CAPACITOR CER. 470 pF
22	1	S240-150-20	RESISTOR 20W 15 Ω
21	1	S240-100-20	20W 10 Ω
20	1	S240-301-05	5W 300 Ω
19	1	S240-7R5-10	10W 7.5 Ω
18	1	S121-15	2W 150 Ω
17	1	S117-64	1W 27 Ω
16	2	S233-472	1/2W 10% 47K
15	3	272	2.7K
14	1	222	2.2K
13	2	182	1.8K
12	2	122	1.2K
11	3	102	1K
10	1	681	680 Ω
9	1	561	560 Ω
8	1	331	330 Ω
7	1	221	220 Ω
6	1	181	180 Ω
5	2	101	100 Ω
4	1	390	39 Ω
3	1	100	10 Ω
2	4	S233-5ELECT	RESISTOR 1/2W 10% SEL.
1	1	B505-060602	POWER SUPPLY B'D RIV.

DATE	2-16-74	OWN	BRADY	APP'D.	Dob	DWN SCALE	EX	USED ON	121	PART NAME	POWER SUPPLY B'D ASSEM.
PRINT	CIN.	GR.	CON.	FAY	DEO.	E.P.T.		REQ.	1		
DISTRIBUTION	FILE			3 1/2	3 1/2			FINISH	~	BM 503-121-100R 1	IT.
<small>ALL DRAWINGS AND SPECIFICATIONS ARE AND REMAIN THE PROPERTY OF THE BALDWIN PIANO & ORGAN CO. AND MUST BE RETURNED TO IT. ALL SPECIFICATIONS ARE CONFIDENTIAL AND ARE NOT TO BE DISCLOSED TO ANY PERSONS OTHER THAN THOSE TO WHOM THEY ARE SENT. NO DRAWINGS, SPECIFICATIONS OR OTHER DATA BELONGING TO THE BALDWIN PIANO & ORGAN CO. WHICH MAY BE FURNISHED TO MANUFACTURERS OR OTHERS FOR ANY PURPOSES ARE TO BE REPRODUCED BY IMPLICATION OR OTHERWISE IN ANY MANNER, LICENSING, THE HOLDER OR ANY OTHER PERSON OR CORPORATION OR CONVEYING ANY RIGHTS OR PERMISSION TO MANUFACTURE, USE OR SELL ANY PATENTED INVENTION THAT MAY IN ANY WAY BE RELATED THERETO.</small>											
UNLESS OTHERWISE SPECIFIED TOLERANCES ARE: DECIMAL ± .008 FRACTIONAL ± .016 ANGLE ± .1°											
NEXT ASSEM. D005-060481 SUPERSEDES C500-060603											
BALDWIN PIANO & ORGAN CO. CINCINNATI, OHIO											
D 500-060603 F											

POWER AMPLIFIER THEORY

Reference: Schematics - C501-051929
Figures - 4, 14 & 15

The Model 121 series organs contain one (1) 25W amplifier located on the bass end of the console floor assembly.

The power amplifier circuit, including heat sinks, is contained on a single printed circuit board assembly and is fastened to the console by four (4) screws.

CIRCUIT DESCRIPTION

The circuit is a Quasi-Complementary silicon power amplifier type. The output stage employs two (2) silicon NPN power transistors, each mounted on a separate heat sink. The driver circuit contains a complementary pair of silicon NPN-PNP medium power transistors. The predrivers, or voltage amplifier circuits, consist of silicon PNP and NPN transistors operating as Class A amplifiers. Two (2) NPN transistors are used as current limiters for amplifier overload protection.

Referring to the 25W Amplifier Schematic, C501-051929, the base of the first voltage amplifier stage (Transistor Q1) is biased from +22V supply via R7 and R11 resistors so that, in conjunction with the D.C. feedback through R12, it sets the D.C. operating point at the junction of Q5 emitter and Q6 collector to about one-half the supply voltage.

The input signal applied from the amplifier level set minipot, (located on the preamplifier board assembly) is amplified by voltage amplifiers Q1 and Q2 to a sufficient level to drive the output stages. The amplified signal from the collector of Q2 is applied to both bases of the complementary drivers, Q3 and Q4. Transistors Q3 and Q5, operating as two emitter followers (Darlington connection), provide a current to the load without phase inversion. Transistor Q4 operates as a common emitter amplifier and its collector supplies signal 180° out of phase to the output stage Q6, which is also a common emitter amplifier. Q6 will invert the signal again and will provide the current for the load. Transistors Q3 and Q4 are slightly forward biased by diodes D1, D2, and resistor R25 to assure the proper switching point and minimize crossover distortion. Resistors R5 and R20, due to the conduction of Q3 and Q4, develop a voltage drop which forward biases the output transistors, Q5 and Q6. Current flowing through output transistors, under no signal condition (idling current), is in the order of a few tenths of a milli-ampere so that the amplifier is operating in Class AB mode.

Resistors R1, R2, and capacitor C1 provide a bootstrapping action to assure sufficient drive to Q3 transistor when the output signal goes positive. The positive output voltage is coupled via C1 capacitor to the junction of R1 and R2, boosting the voltage to allow sufficient current to drive Q5 output transistor.

The output transistor emitter resistors R10 and R23 are fusing type resistors, which will open the circuit under high currents and prevent any further damage to the output power transistors.

Additional short circuit protection is provided by the current limiting transistors Q7 and Q8. Under high current condition, voltage drop on fuse link resistors R10 and R23 will be high enough to forward bias transistors Q7 and Q8, which will saturate and limit the drive to the driver transistors.

Components R6, R9, and D3, and R16, R19, and D4 reduce the limiting action of Q7 and Q8, respectively, when an output signal is present (not shorted), permitting the amplifier to be driven to full output.

Capacitor C9 provides a high frequency limit for the amplifier.

The noise suppressor circuit consists of diode D5 and capacitor C6 and an external circuit (its operation is described under Preamplifier Theory), which, when the organ power is switched on, keeps the outputs of the amplifiers near ground until all supply voltages are stabilized, thus preventing any audible transients. When the organ is turned on, diode D5 is forward biased and rapidly charges capacitor C6, temporarily saturating Q1. After stability is achieved, diode D5 cuts off, permitting the normal operation of the amplifier. Additional delay circuit incorporated on 121 models consists of R1, R26 and C21, 100 mfd electrolytic capacitor, also located on the preamp board assembly, delays the application of +53 V.D.C. supply to the driver stage (Q3) when the organ is just turned on, thus preventing audible transients.

RELEASED

Ord. No. RN 592
Date 3-4-71

- A) ADDED R25 5-21-71 W.R.M.
- B) R25 WAS 33K 11-71 W.R.M.
- C) Q5 Q6 WERE ASIA Q41830 C.N.14733 11-71 W.R.M.
- D) C6 WAS 100uF @ 25V, CHANGED TO 100uF @ 50V C.N.14907 H.C.R. 5-11-72
- E) Q1 WAS .025A 5-14-72 C.N.14733 11-71 W.R.M.
- F) ADDED INFORMATION FOR TECHNICAL SERVICE DEPT. C.N.15077 H.C.R. 9-22-72
- G) REVISED NOTES 5-16-73 C.N.15305 D.L.L. 4-4-73
- H) R1 WAS 1.5K; R2 WAS 1.5K; R25 WAS 33K. ADDED R24. REVISED NOTE 5. DELETED NOTE 6. NOTES 6 ADDED WHERE APPLICABLE. LAST R.C.N. WAS 25 C.N.15404 H.C.R. 5-17-73
- I) REVISED TO PROVIDE HIGH FREQ. SIGNAL OUTPUT (WHERE APPLICABLE) C.N.15652 M.S. 12-4-73

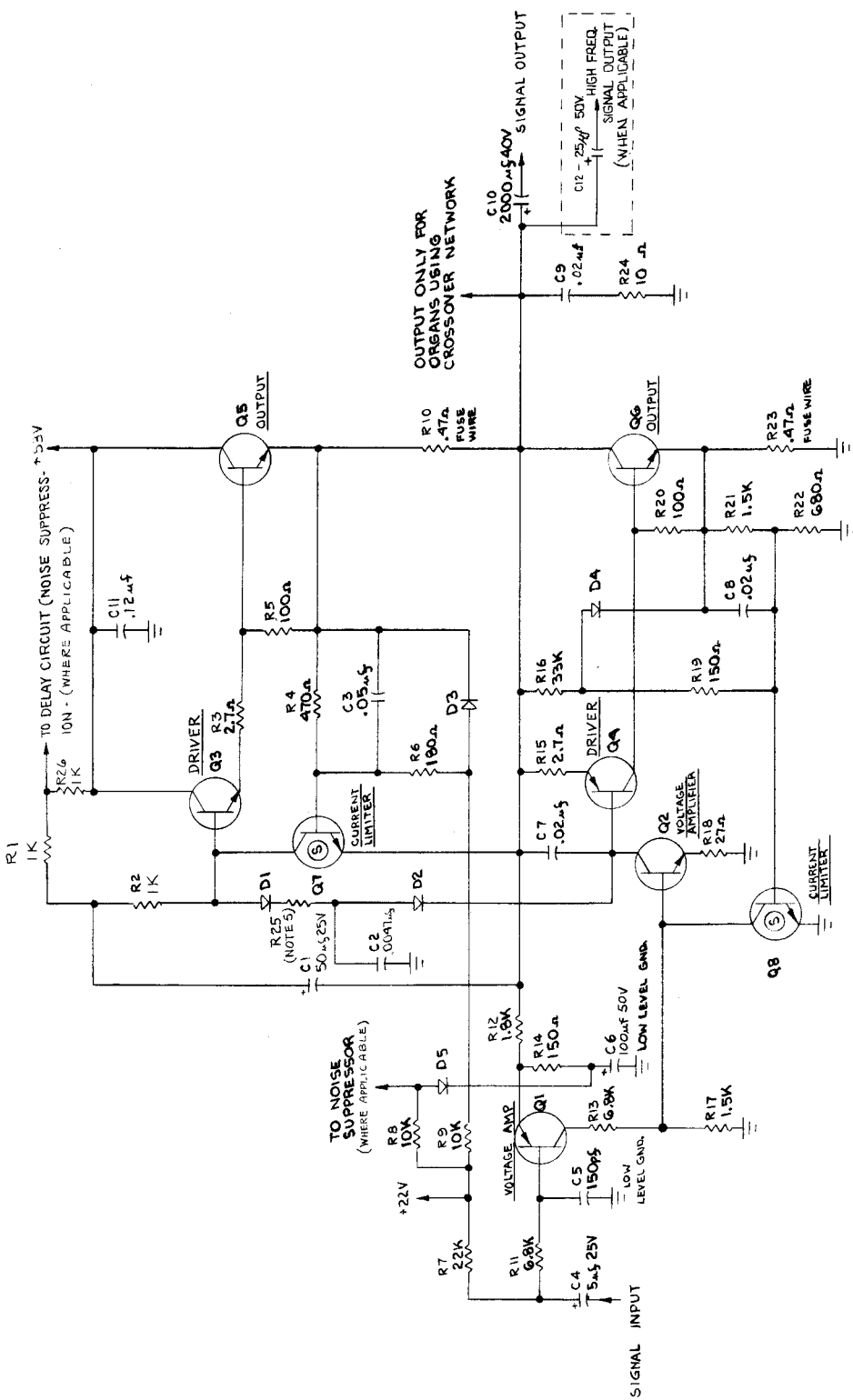

- NOTES:
1. ALL RESISTORS ARE 1/2W 10% UNLESS OTHERWISE SPECIFIED.
 2. D.C. VOLTAGE MEASUREMENTS TAKEN WITH A VOLTMETER (20,000 OHM PER VOLT OR HIGHER) FROM POINT INDICATED TO GROUND.
 3. ALL GROUNDS ARE HIGH LEVEL AMPLIFIER GROUNDS UNLESS OTHERWISE SPECIFIED.
 4. Q1 - PNP SILICON TRANSISTOR (A514-044910)
Q2 - PNP MEDIUM POWER SILICON TRANSISTOR (A514-041828)
Q3 - PNP MEDIUM POWER SILICON TRANSISTOR (A514-047829)
Q4 - PNP MEDIUM POWER SILICON TRANSISTOR (A514-054214)
Q5 - PNP MEDIUM POWER SILICON TRANSISTOR (A514-054214)
Q6 - PNP MEDIUM POWER SILICON TRANSISTOR (A514-033338) SELECTED PER 5429-2
Q7 - PNP MEDIUM POWER SILICON TRANSISTOR (A514-042791)
Q8 - PNP MEDIUM POWER SILICON TRANSISTOR (A514-042791)
 5. SELECT R25 TO OBTAIN 400 mV ± 50 mV AT BASE OF Q6 (REF. 5607).
- CAUTION: AMPLIFIER MUST BE COLD WHEN SELECTING THIS VOLTAGE.

LAST COMP NG USED				
R	C	Q	D	5
26	12	8	5	

RECORD OF CHANGE	
25W AMPLIFIER SCHEMATIC	IT.
USED ON C.6.30.1.2.0	REV. NO.
REV. NO.	SUPPLEMENT

PART NAME	
25W AMPLIFIER SCHEMATIC	IT.
USED ON C.6.30.1.2.0	REV. NO.
REV. NO.	SUPPLEMENT

D. H. BALDWIN CO.
CINCINNATI, OHIO

501-051929

25W POWER AMPLIFIER BOARD ASSEMBLY

SCHEMATIC No. C501-051929

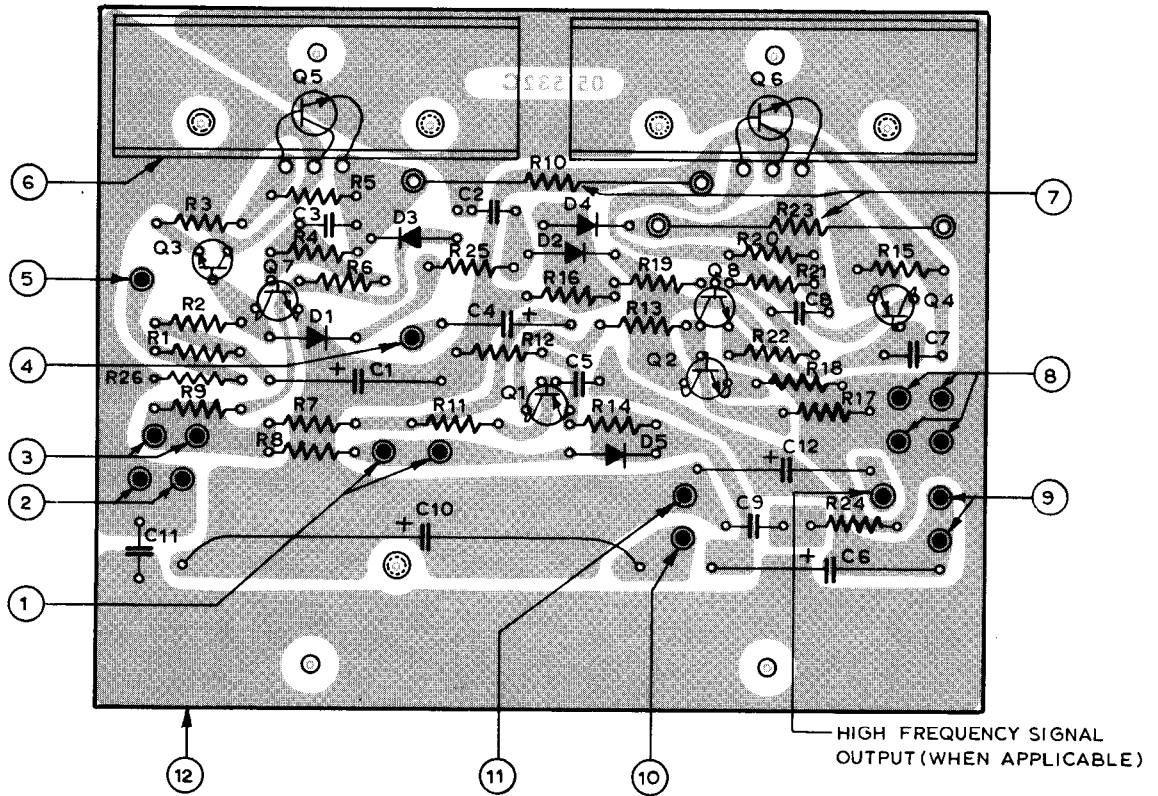

ITEM	DESCRIPTION	WIRE COLOR/PART NO.
1	TO NOISE SUPPRESSOR CIRCUIT (WHEN APPLICABLE)	RED #2
2	+53VDC SUPPLY INPUT	WHITE
3	+22VDC SUPPLY INPUT	ORANGE
4	SIGNAL INPUT	SINGL. COND. SH. #4
5	TO DELAY CIRCUIT (WHEN APPLICABLE)	
6	HEATSINK	B528-051906
	TRANSISTOR SOCKET	B507-033322
	TRANSISTOR MICA INSULATOR	A514-033359
	SILICON COMPOUND	A249-016587
7	FUSING WIRE	A514-033375
8	HIGH LEVEL GROUND	BLACK #18 AWG
9	LOW LEVEL GROUND	BLACK #18 AWG
10	SIGNAL OUTPUT	BROWN #18 AWG
11	CROSSOVER SIGNAL OUTPUT (WHEN APPLICABLE)	VIOLET
12	25W POWER AMPLIFIER BOARD ASSEMBLY	B500-060514

FIGURE 15

MODEL 121W GENERAL INFORMATION

The Model 121W features the FUN BASS that is not available on the 121F. This requires newer and different logic. In addition, the amplifier has been updated to use the latest design, and board assemblies have been updated to enable use of the latest manufacturing facilities. It is therefore essential that

PART NUMBERS AVAILABLE IN THE 121W SECTION BE
USED WHEN ORDERING MODEL 121W PARTS.

For 121W information not contained in the 121W section, refer to the previous section.

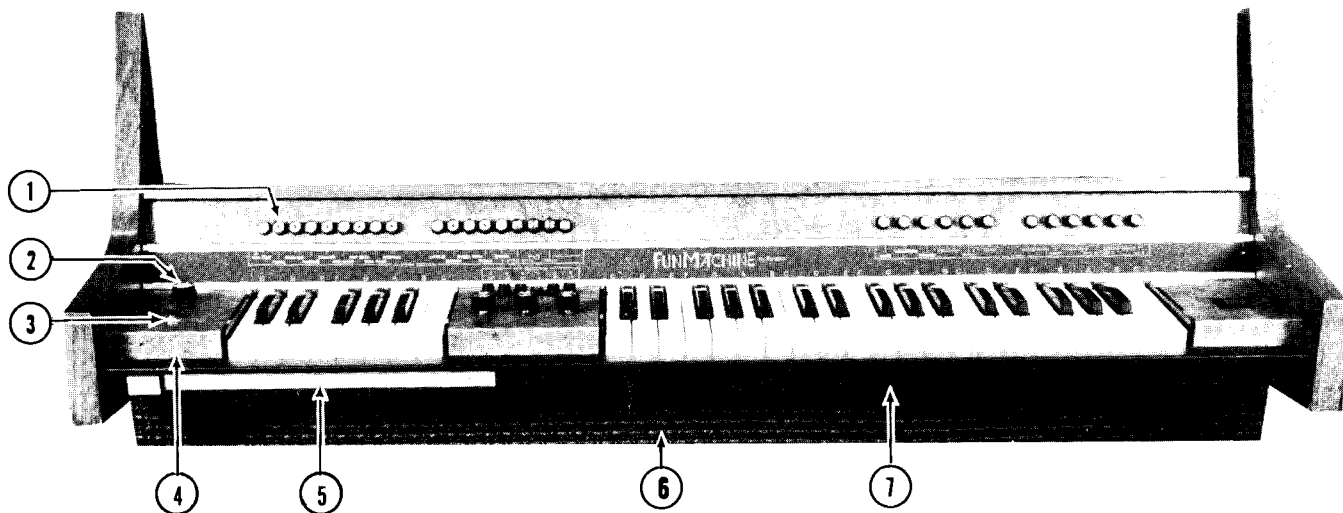

FIG. 16 - 121W CONTROLS AND KEYBOARD

1.	Push Button - Insert Type	0250-054568
	Push Button Insert - Dotted	0247-100811
2.	Fun Bass Control	
	Knob	0247-057795
	Fun Bass Insert	0249-100763
	Fun Bass Knob Assembly	0247-100764
	Pull Up Switch	0509-100666
3.	Headphone Jax Assembly	0500-060236
4.	Accompaniment Bass Keycap Assembly	0500-100749
5.	Touch Strip Assembly	0500-100690
6.	Grille Cloth	0244-100920
7.	Accompaniment Keyslip	0528-100819

121W WITH ACRYLIC BUTTON INSERTS
BEGINNING SERIAL #59877

1.	Knob Push Button - Acrylic	0250-102115
	Insert Push Button Blue Acrylic	0247-103132
	Insert Push Button Red Acrylic	0247-103131
	Insert Push Button Dot Acrylic	0247-103128
	Insert Push Button White Acrylic	0247-103129

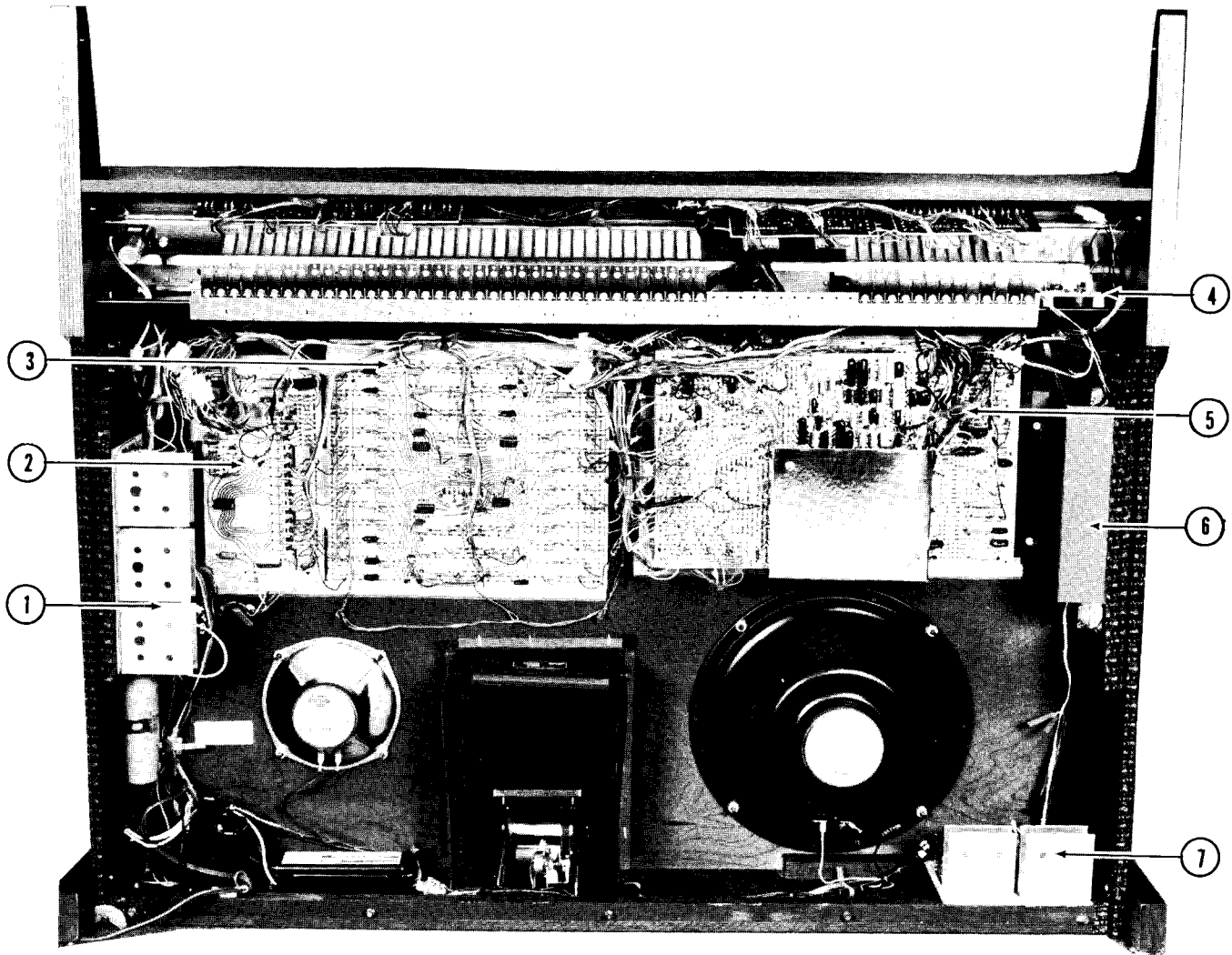

FIG. 17 - 121W REAR

- | | | |
|----|--|-------------|
| 1. | Power Supply Board Assembly | 0500-060603 |
| 2. | TOFG Board Assembly | 0500-060640 |
| 3. | Gate & Divider Board Assembly | 0500-103520 |
| 4. | Touch Strip Interface Board Assembly | 0500-100615 |
| 5. | Fun Machine Boards Assembly | 0500-100750 |
| | Top-Right Hand Board Assembly | |
| | Middle - Rhythm Voice Board Assembly | |
| | Bottom (Large) - Logic Board Assembly | |
| 6. | Preamp Board Assembly | 0500-060447 |
| 7. | 25 Watt Power Amplifier Assembly | 0500-100447 |

FUN MACHINE BOARDS AVAILABLE AS COMPLETE FUN MACHINE BOARDS ASSEMBLY ONLY

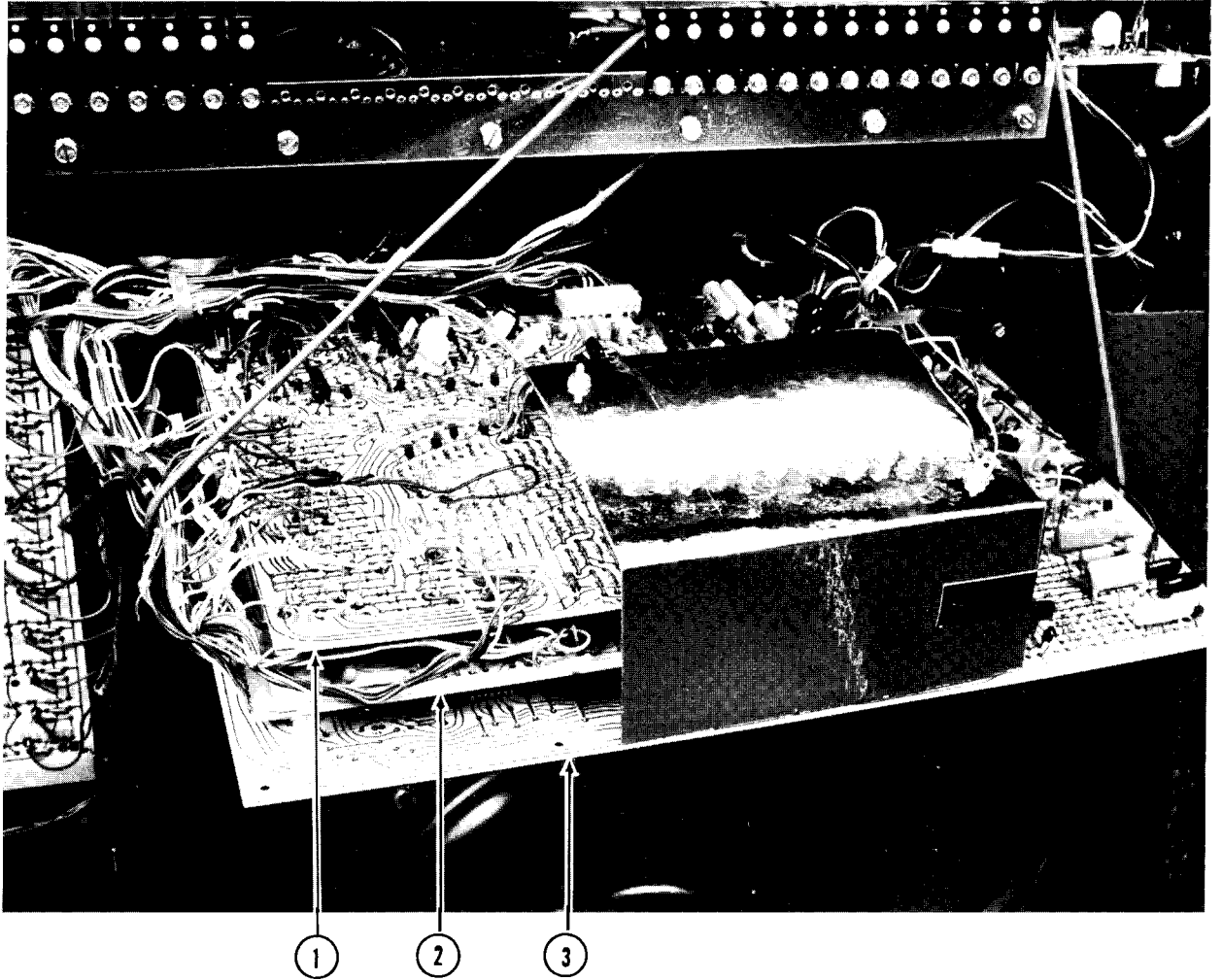

FIG. 18 - 121W FUN MACHINE BOARDS ASSEMBLY

- 1. Right Hand Board Assembly
 - 2. Rhythm Voice Board Assembly
 - 3. Fun Machine Logic Board Assembly
- Fun Machine Boards Assembly 0500-100750

FUN MACHINE BOARDS AVAILABLE AS COMPLETE FUN MACHINE BOARDS ASSEMBLY ONLY

NOTES:

- 1.
2. REFERENCE SCHEMATIC - D5D1-060684
3. PIN WIRING DIAGRAM - B5D1-060641
4. SELECT RS12 FOR A 6.4 HZ VIB. FREQUENCY SELECTION RANGE 27K TO 820K.
5. SELECT RS10 FOR VIB. EXTENT OF 3% WITH R13 AT MAX. VIBRATO SELECTION RANGE 1.2K TO 150K.
7. TUNE TO 1046.5 HZ @ "C" 61.
8. SELECT Q3 PER S429-AS INDICATED.
9. FINAL ASSEM. MUST INCLUDE PART NUMBER 0500-102983...
10. Q8 & Q9 DO NOT USE G.E. TRANSISTORS.

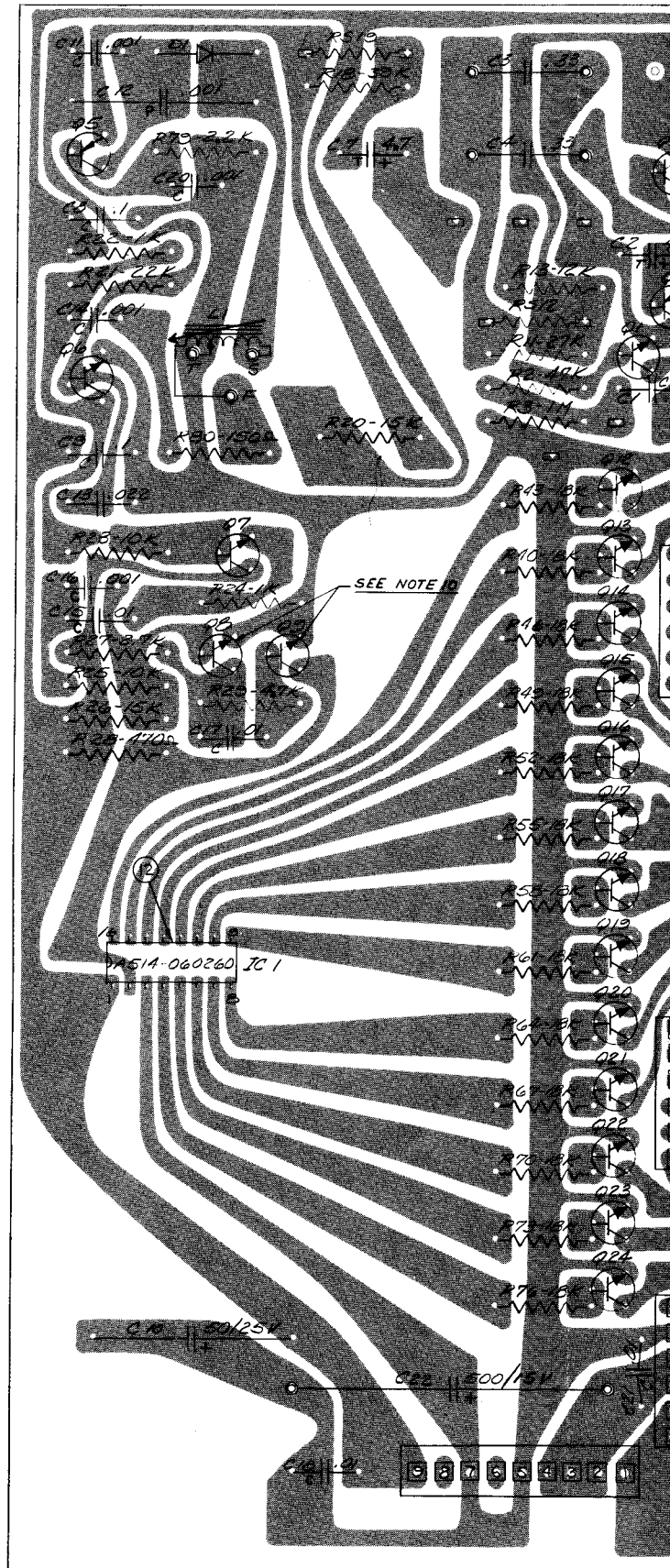

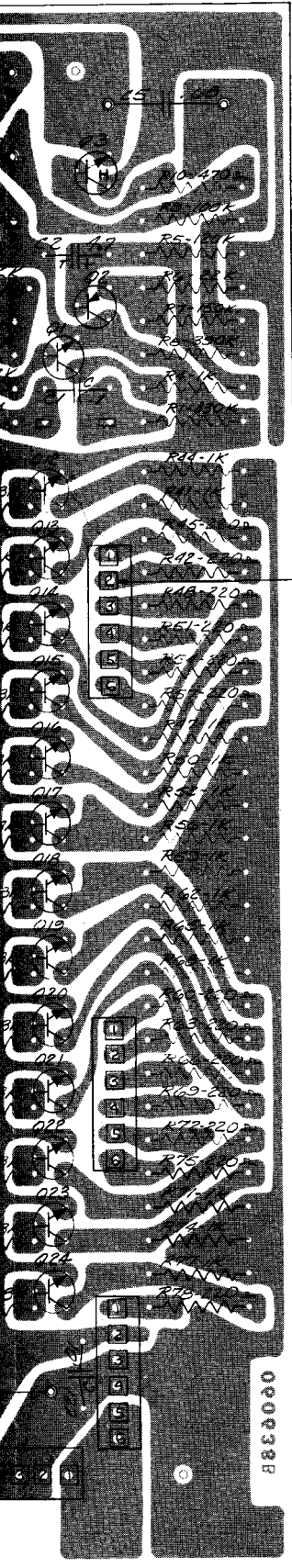

SEE NOTE 7 (C'6)

LEGEND:
 "C" DENOTES CERAMIC CAPACITOR
 "T" DENOTES TANTALUM CAPACITOR
 "P" DENOTES POLYMYLAR CAPACITOR
 CAPACITORS UNMARKED ARE MYLAR
 CAPACITORS MARKED WITH A POLARITY
 SIGN ARE ELECTROLYTIC.

ITEM NO.	QTY	PART NO.	PART NAME
53			
52			
51	1	5239-393-10	RESISTOR 39K 1/2W 10%
50	1	5239-151-10	RESISTOR 150Ω 1/2W 10%
49	1	5239-105-10	RESISTOR 1M 1/2W 10%
48	X	5134-4	SOLDER IRON
47	X	5184-3	SOLDER DIP
46			
45	2	5244-20-475-2	CAP. 4.7 NF TANTALUM
44	1	5211-015-500	500MF 15V ELECT.
43	1	5211-025-050	50 MF 25V ELECT.
42			
41	3	5218-104	.1 CERAMIC
40	4	5206-103	.01 CERAMIC
39	4	5205-102	.001 CERAMIC
38	1	5232-01-684	.68 MYLAR
37	2	5232-01-334	.33 MYLAR
36	1	5232-01-223	.022 MYLAR
35	1	5411-01-102	CAP. 001 POLYMYLAR
34	2	5239-XXX-10	RESISTOR SEL. 1/2W 10%
33	1	394	390K
32	1	334	330K
31	1	124	120K
30	1	154	150K
29	1	104	100K
28			
27	1	473	47K
26	1	273	27K
25	2	223	22K
24	13	183	18K
23	2	153	15K
22	1	123	12K
21	2	103	10K
20			
19	1	472	4.7K
18	1	272	2.7K
17	1	222	2.2K
16	16	102	1K
15	2	471	470Ω
14	13	5239-221-10	RESISTOR 220Ω 1/2W 10%
13			
12	1	514-061891	DIP SOCKET-16. CONN. SEE DIM. DWG. A514-061899
11			
10			
9	1	B612-060328	T.O.F.G. COIL ASS'Y
8			
7			
6	1	A514-060260	MOSFET (T.O.F.G.)
5	1	A514-033903	DIODE-HIGH VOLTAGE
4			
3	2	A514-044910	TRANSISTOR-PNP
2	19	A514-033338	TRANSISTOR-NPN
1	1	B0505-102982	T.O.F.G. 8'D RIVETED

DATE 8-30-74	DWN. BRADY	APPD. 9-16-74	DRW. SCALE 2X SIZE	USED ON 121-121	PART NAME TOP OCTAVE FREQUENCY GENERATOR 8'D ASSEMBLY
PRINT CIL. GR. CON.	FAY. DEQ. E.P.T.	48L 18R. 3 BL.	FINISH 1	BAL 505-121-5 505-121-5	GR. 2 IT.
DISTRIBUTION FILE			NEXT ASSEM. 2003-060981 SUPERSEDES 2000-060690		
UNLESS OTHERWISE SPECIFIED TOLERANCES ARE: DECIMAL ±.005 FRACTIONAL ±.015 ANGLE ±.1°			BALDWIN PIANO & ORGAN CO. CINCINNATI, OHIO		
			D 0500-102983		

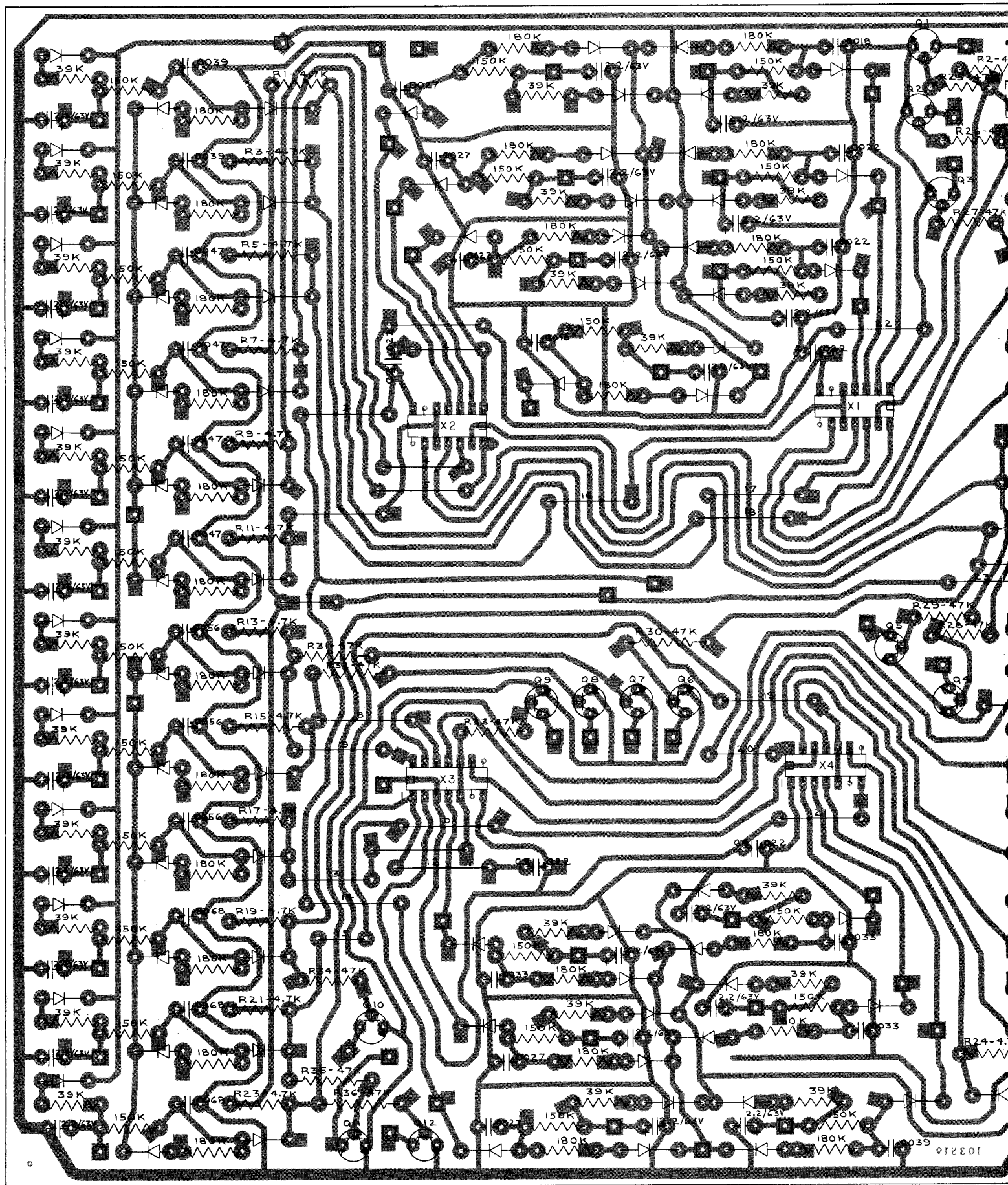

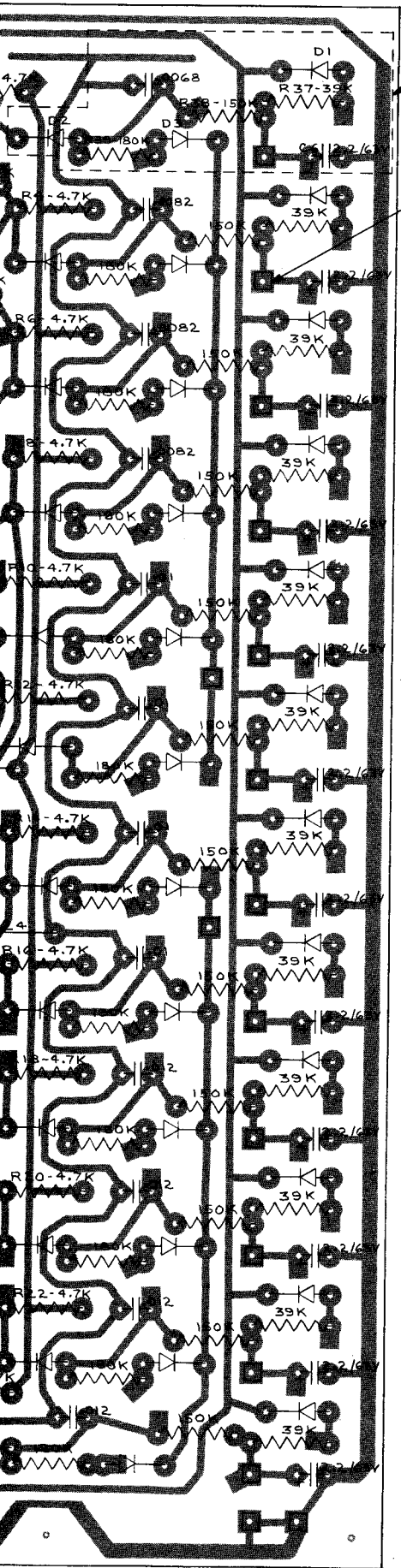

TYPICAL CKT. FOR 37 GATES.

WIRE WRAP PINS - 75 REQUIRED AS SHOWN (ITEM 28)
 EXTENDING .600/.610 ABOVE BD. ON COMPONENT SIDE.

NOTES:

1. REF. SCHEM. C0501-060143, WIR. DIA. C0501-103522.
2. PIN WIRING DIA. C0501-103522.
3. ALL CAPACITOR VALUES ARE IN MFD. CAPACITORS MARKED "+" ARE ELECTROLYTIC, UNMARKED CAPACITORS ARE MYLAR.
4. FINAL ASSY TO INCLUDE PART NO. 0500-103520.

31	X	S3134-000006	SOLDER-IRON		
30	X	S3184-000003	SOLDER-DIP		
29	X	S3137-000022	WIRE BARE COPPER #22 (24 JUMPERS)		
28	5'	A0516-102698	WIRE .045 SQUARE		
27					
26	37	S3257-163229	CAPACITOR ELECT	2.2 μ F @ 63V	
25	4	S3258-050223	MYLAR	.022 μ F	
24	4	-050123		.012 μ F	
23	4	-050103		.010 μ F	
22	3	-050822		.0082 μ F	
21	4	-050682		.0068 μ F	
20	3	-050562		.0056 μ F	
19	4	-050472		.0047 μ F	
18	3	-050392		.0039 μ F	
17	3	-050332		.0033 μ F	
16	4	-050272		.0027 μ F	
15	3	-050222		.0022 μ F	
14	2	S3258-050182	CAPACITOR MYLAR	.0018 μ F	
13					
12	37	S3250-000184	RESISTOR 1/4W	180K	
11	37	-000154		150K	
10	12	-000473		47K	
9	37	-000393		39K	
8	24	S3250-000472	RESISTOR 1/4W	4.7K	
7					
6	1	C0508-060686	GATE OUTPUT CABLE (NOT SHOWN)		
5	111	A0514-042791	DIODE MED VOLTAGE		
4	12	A0514-033338	TRANSISTOR NPN		
3	4	0514-061890	SOCKET DIP - 14 PIN		
2	4	A0514-061735	I.C. 7 STAGE FREQUENCY DIVIDER		
1	1	A0575-103519	BD, DEM GATE DIV		
ITEM	QTY	PART NO	PART NAME		

DATE 1-8-79 DWN. J.L.A.FOLLETTE CHD APPD. Q16 DWN. SCALE 2X USED ON 121W PART NAME
 PRINT CIN. GR. CON. 1.000 2.000 3.000 4.000 5.000 6.000 7.000 8.000 9.000 10.000 11.000 12.000 13.000 14.000 15.000 16.000 17.000 18.000 19.000 20.000 21.000 22.000 23.000 24.000 25.000 26.000 27.000 28.000 29.000 30.000 31.000 32.000 33.000 34.000 35.000 36.000 37.000 38.000 39.000 40.000 41.000 42.000 43.000 44.000 45.000 46.000 47.000 48.000 49.000 50.000 51.000 52.000 53.000 54.000 55.000 56.000 57.000 58.000 59.000 60.000 61.000 62.000 63.000 64.000 65.000 66.000 67.000 68.000 69.000 70.000 71.000 72.000 73.000 74.000 75.000 76.000 77.000 78.000 79.000 80.000 81.000 82.000 83.000 84.000 85.000 86.000 87.000 88.000 89.000 90.000 91.000 92.000 93.000 94.000 95.000 96.000 97.000 98.000 99.000 100.000
 DISTRIBUTION FILE 2BL 1BR 3BL REQ. SEE B/W FINISH B/M 503-121W-5GR.1 IT.
 ALL DRAWINGS AND SPECIFICATIONS ARE AND REMAIN THE PROPERTY OF THE BALDWIN PIANO & ORGAN CO. AND MUST BE RETURNED TO IT. ALL SPECIFICATIONS ARE CONFIDENTIAL AND ARE NOT TO BE DISCLOSED TO ANY PERSON OTHER THAN THOSE TO WHOM THEY ARE SENT. NO DRAWINGS, SPECIFICATIONS OR OTHER DATA BELONGING TO THE BALDWIN PIANO & ORGAN CO. WHICH MAY BE FURNISHED TO MANUFACTURERS OR OTHERS FOR ANY PURPOSE ARE TO BE REPRODUCED BY APPLICATION OR OTHERWISE AS IN ANY MANNER LICENSED BY THE HOLDER OR ANY OTHER PERSON OR CORPORATION OR CONVEYING ANY RIGHTS OR PERMISSION TO MANUFACTURE, USE OR SELL ANY PATENTED INVENTION THAT MAY IN ANY WAY BE RELATED THEREOF.
 NEXT ASSEM. SUPERSEDES
 BALDWIN PIANO & ORGAN CO. CINCINNATI, OHIO D 0500-103520

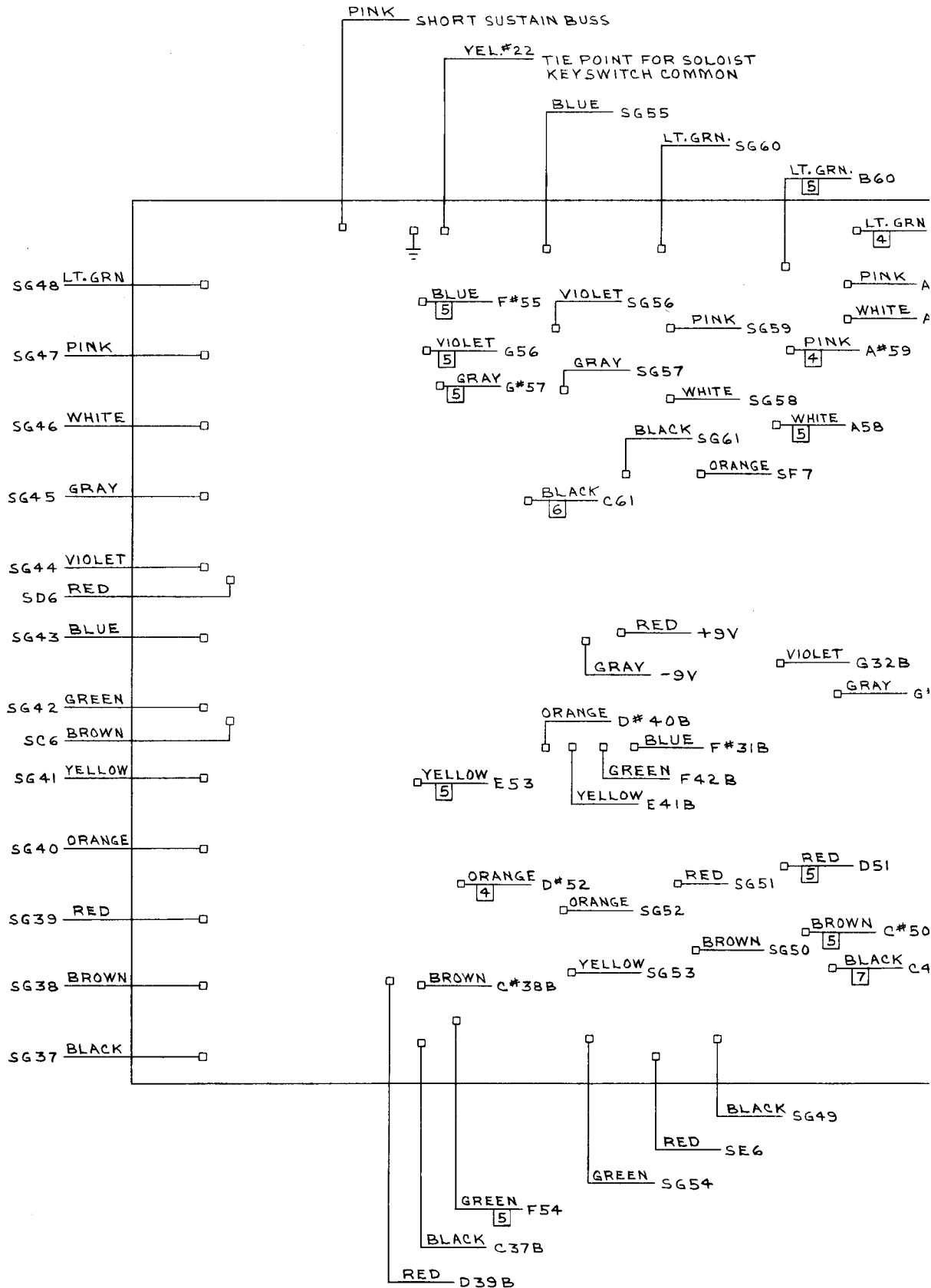

DATE 1-12-79	DWN.	J.L.A.F.O.L.
PRINT DISTRIBUTION	CIN.	GR
	S	
<small>ALL DRAWINGS AND SPECIFICATIONS ARE RETURNED TO IT. ALL SPECIFICATIONS ARE TO WHOM THEY ARE SENT. NO DRAWING WHICH MAY BE FURNISHED TO MANUFACTURER OR PERMISSION TO MANUFACTURE, USE OR PERMISSION TO MANUFACTURE, USE UNLESS OTHERWISE SPECIFIED</small>		

RELEASED

Ord. No. C. N. 18,170
Date 11/15/79

RECORD OF CHANGE

SUSTAIN BUSS

#22 TIE POINT FOR SOLOIST
KEYSWITCH COMMON

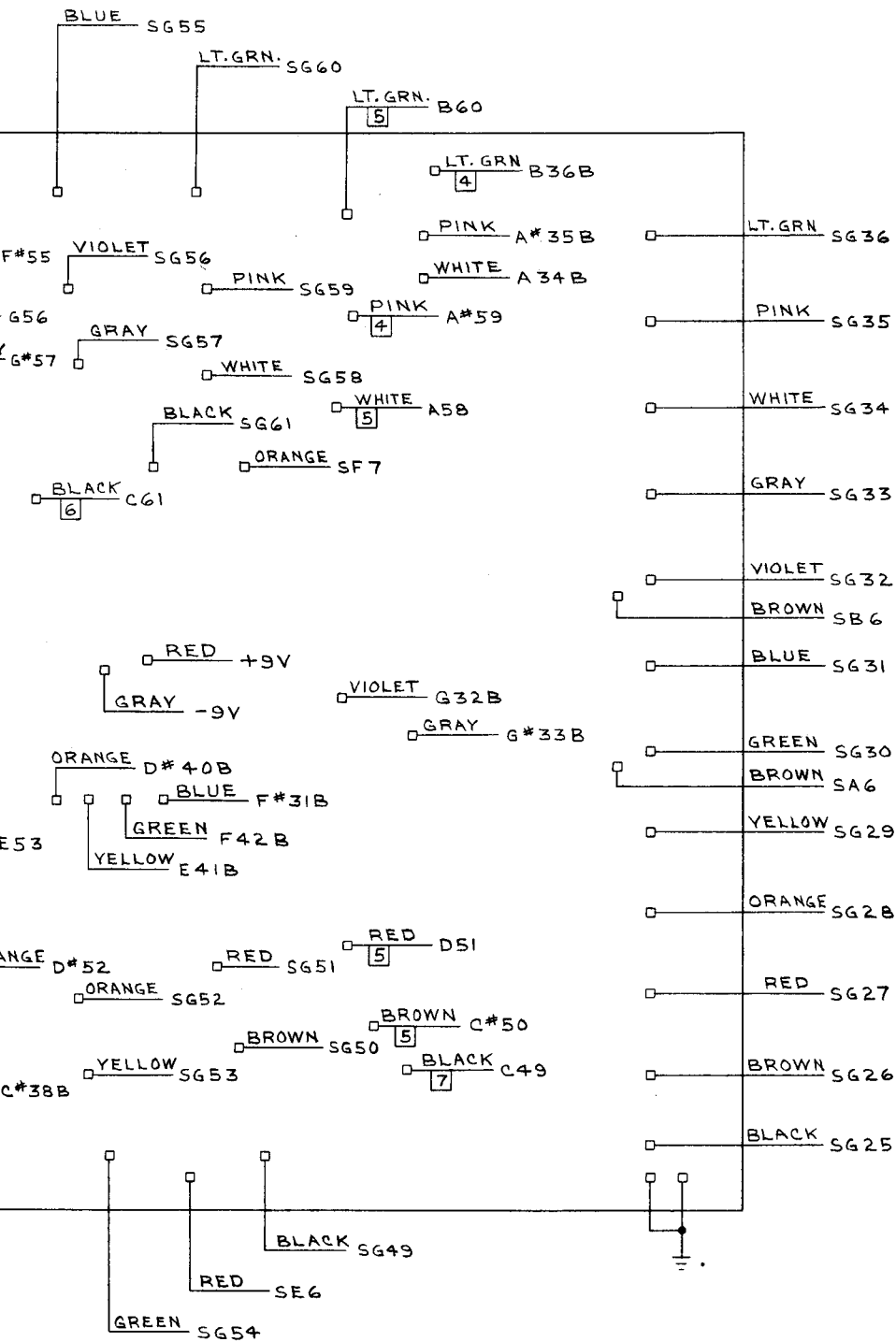

EN F54

C37B

B

DATE 1-12-79		DWN J.L. FOLLETTE		CHKD	APP'D. <i>gls</i>	DWN SCALE FULL	USED ON 121W	PART NAME			
PRINT DISTRIBUTION		CIN.	GR.	CON.	FAY.	DEQ.	E.P.T.	REQ. SEE B/M	DIA, WIRING BD GATE DIV		
		S			2BL1BR	3BL		FINISH	B/M 503-121W-5GR. NOTED IT.		
ALL DRAWINGS AND SPECIFICATIONS ARE AND REMAIN THE PROPERTY OF THE BALDWIN PIANO & ORGAN CO. AND MUST BE RETURNED TO IT. ALL SPECIFICATIONS ARE CONFIDENTIAL AND ARE NOT TO BE DISCLOSED TO ANY PERSONS OTHER THAN THOSE TO WHOM THEY ARE SENT. NO DRAWINGS, SPECIFICATIONS OR OTHER DATA BELONGING TO THE BALDWIN PIANO & ORGAN CO. WHICH MAY BE FURNISHED TO MANUFACTURERS OR OTHERS FOR ANY PURPOSE ARE TO BE REGARDED BY IMPLICATION OR OTHERWISE AS IN ANY MANNER LICENSING THE HOLDER OR ANY OTHER PERSON OR CORPORATION OR CONVEYING ANY RIGHTS OR PERMISSION TO MANUFACTURE, USE OR SELL ANY PATENTED INVENTION THAT MAY IN ANY WAY BE RELATED THERETO.								NEXT ASSEM.		SUPERSEDES	
UNLESS OTHERWISE SPECIFIED TOLERANCES ARE: DECIMAL ±.005 FRACTIONAL ±.015 ANGLE ±1/2°								BALDWIN PIANO & ORGAN CO. CINCINNATI, OHIO		C 0501-103522	

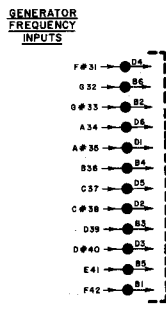
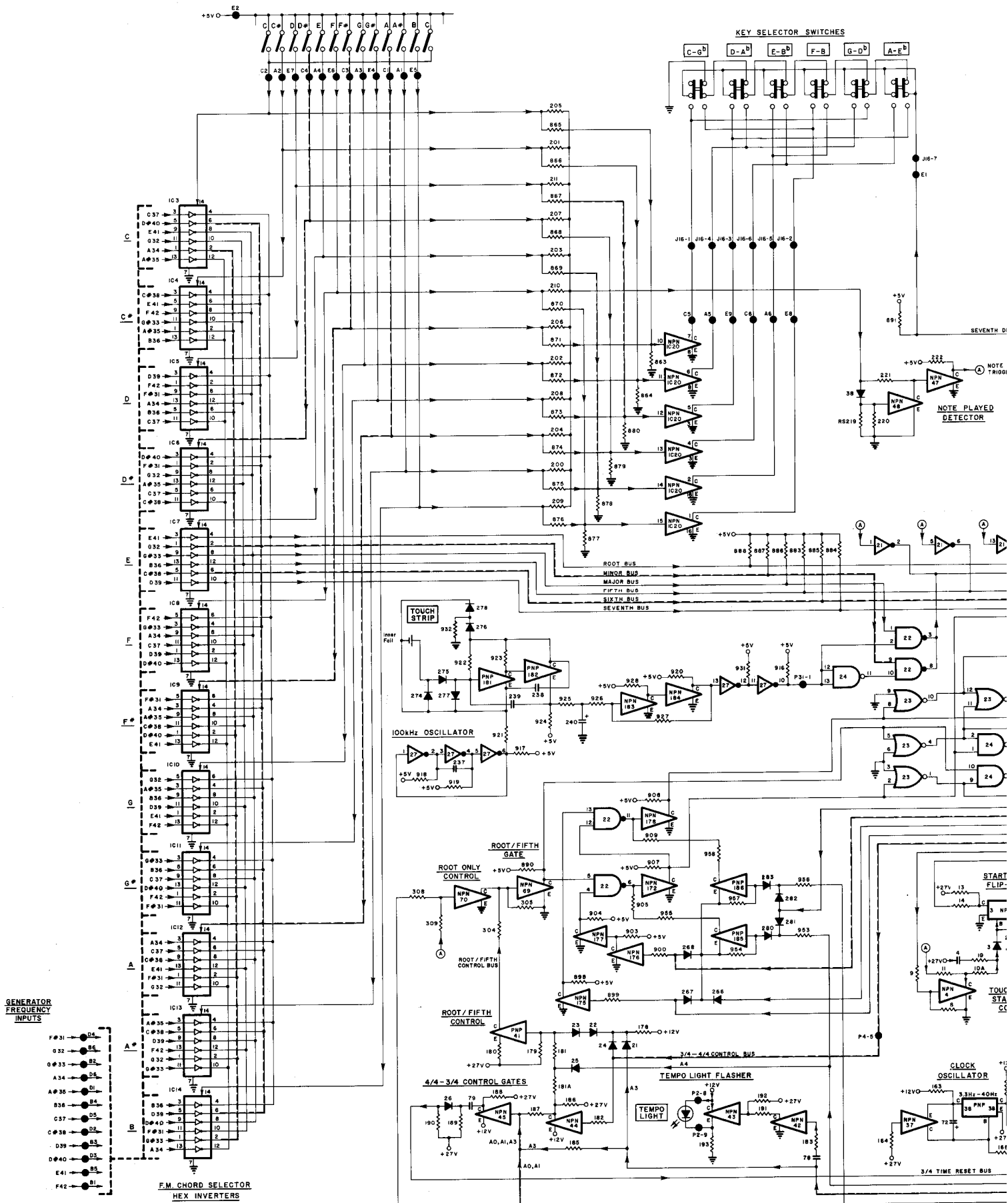

F.M. CHORD SELECTOR
HEX INVERTERS

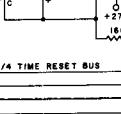
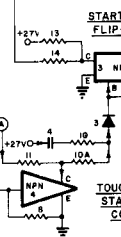
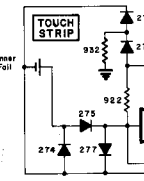
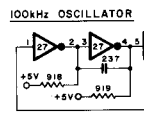
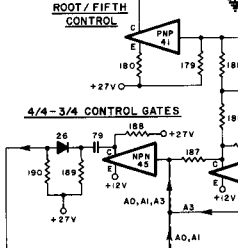
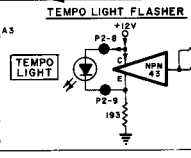
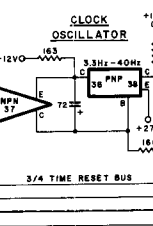

ROOT BUS
MINOR BUS
MAJOR BUS
FIFTH BUS
SIXTH BUS
SEVENTH BUS

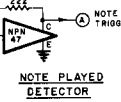

SEVENTH DI

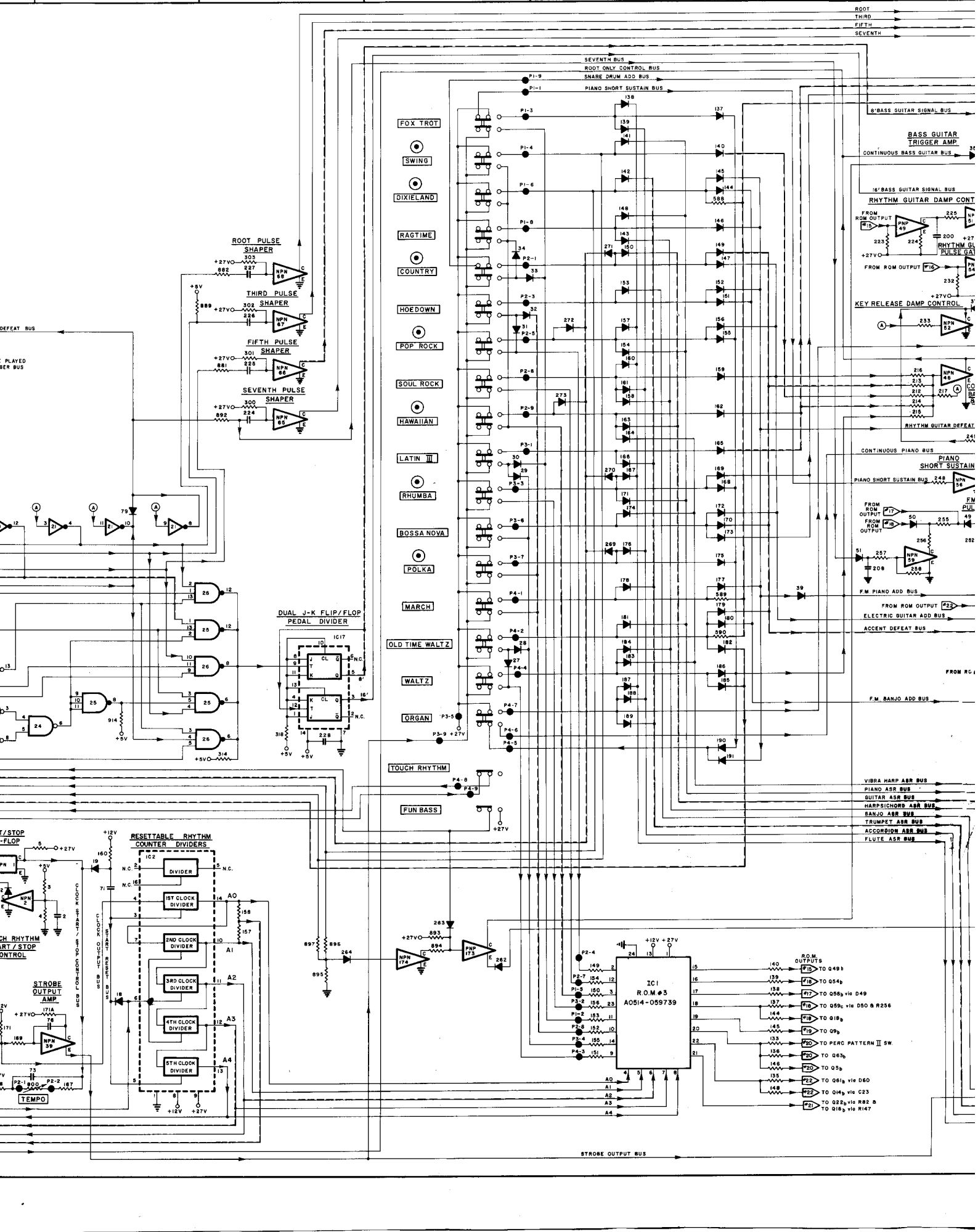

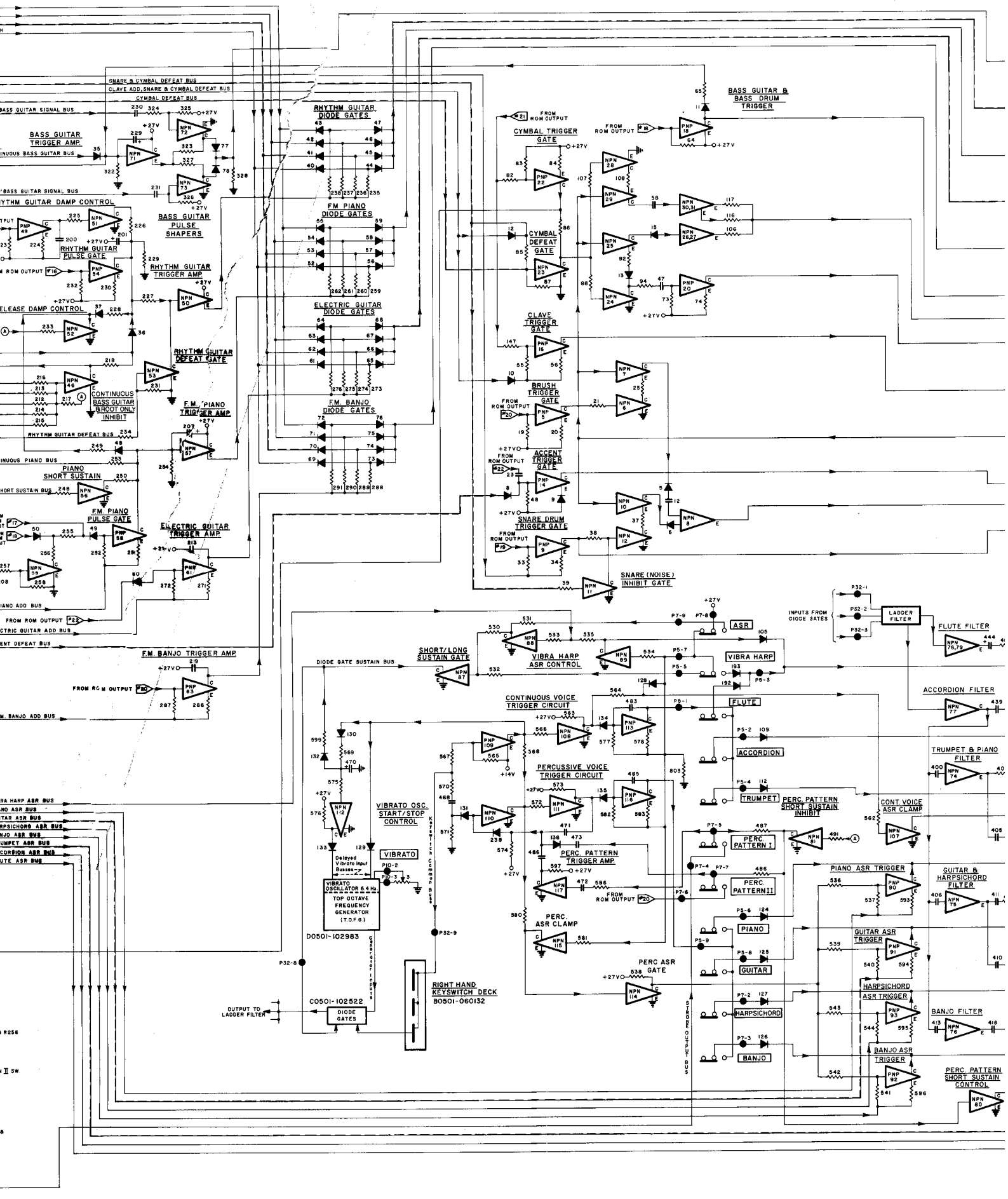

A

B

C

D

E

F

G

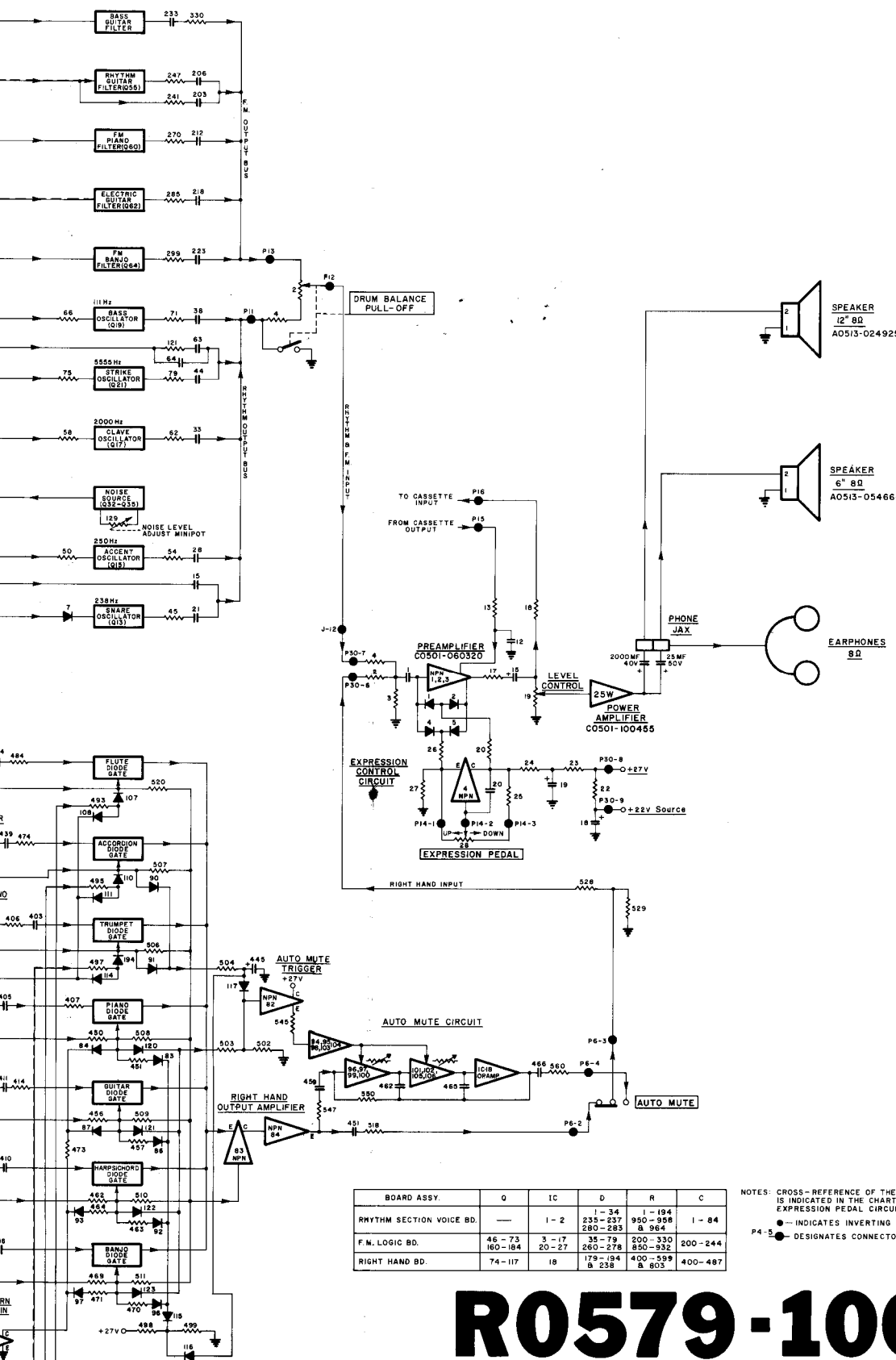

BOARD ASSY.	Q	IC	D	R	C
RHYTHM SECTION VOICE BD.	---	1-2	1-34, 230-237 280-283	1-194 950-988 & 964	1-84
F.M. LOGIC BD.	46-73 160-184	3-17 20-27	35-79 260-278	200-330 850-932	200-244
RIGHT HAND BD.	74-117	18	179-194 & 238	400-509 & 803	400-487

NOTES: CROSS-REFERENCE OF THE COMPONENT NUMBER TO ITS LOCATION IS INDICATED IN THE CHART. PREAMP, POWER AMP, & EXPRESSION PEDAL CIRCUITS ARE NOT INCLUDED IN THIS CHART.
 ● INDICATES INVERTING OPEN COLLECTOR DEVICE.
 P4-2 ● DESIGNATES CONNECTOR AND PIN NUMBER (CONNECTOR P4 PIN-5)

R0579-100043

121W BLOCK DIAGRAM

SEPT 24, 79
 DWN R. K. K...
 CHD.

FUN BASS THEORY

Fun Bass is a new feature which has been added to the Fun Machine automatic chord system. Fun Bass circuitry increases the capability of the bass section of the system so that in addition to the usual root and fifth bass pitches, the third, sixth, and seventh pitches are also made available and are included in the bass line of several rhythms. Fun Bass may be cancelled by pulling up on the Fun Bass Cancel switch, returning the bass portion of the rhythm pattern to a normal root/fifth.

Listed are the seven rhythm patterns that can include Fun Bass:

Swing	Hawaiian
Dixieland	Rhumba
Country	Polka
Pop Rock	

A black dot in the center of a rhythm select push button switch indicates that Fun Bass is available in that rhythm pattern.

Fun Bass pedal rhythm patterns are shown in chart form below:

COUNT	1st Measure																2nd Measure															
	1	2	3	4	5	6	7	8	9	10	11	12	13	14	15	16	17	18	19	20	21	22	23	24	25	26	27	28	29	30	31	32
SWING	R				3					5				6			7				6				5					3		
DIXIELAND	R				R					5				5			7				6				5					3		
COUNTRY	R									5							R								5					3		
POP ROCK	R						R			5					5		R						R		5						3	
HAWIIAN	R									5							R								5					3		
RHUMBA	R									5				5			R								5					3		
POLKA	R									5							R								5					3		

R = ROOT 3 = THIRD 5 = FIFTH 6 = SIXTH 7 = SEVENTH — BASS PITCHES

FUN BASS TECHNICAL DESCRIPTION

The Fun Bass circuit is located on the Fun Machine logic board assembly, which is the bottom board in the Fun Machine Boards Assembly on all instruments with Fun Bass, 121W, 123W, 127W, and 128W.

The following technical description is supplemental to previously published Fun Machine theory. Fun Bass circuits have been added to the basic Fun Machine circuit resulting in alteration of automatic chording, key selector, and bass frequency control logic.

FUN MACHINE CHORD LOGIC

On Fun Bass organs, an additional generator frequency, the sixth for each of the twelve chords, has been added. Thus, the chord selector hex inverters (IC3-14) can supply all the pitches required by the Fun Bass logic circuit in addition to the normal inputs required for manual chords. This additional chord frequency necessitates the addition of a six transistor array (IC20) in the key selector circuit.

KEY SELECTOR

The resulting key selector function is unchanged. For instance, when the C - G^d key selector switch is depressed, four keys in the Fun Machine range will play a triad chord. Those chords are C, F, F#, and B, all other keys play a seventh chord. For example, when C is played and the C - G^d key selector switch is closed, +5V from the keyswitch is applied both to pin 14 of IC3 and via R865 to pin 10 of IC20. IC20 pin 10 is the base of an array transistor, the collector of which is connected to the seventh defeat bus (IC21 pin 8) via key selector switch S32. Playing C in the Fun Machine range then, in addition to gating the required pitches for the C chord, saturates the array transistor, which grounds the seventh bus. For this example, if C# is played, the array transistor saturated by the keyswitching voltage is not connected to the seventh defeat bus via the key selector switches, and therefore, the seventh is heard in the C# chord.

FUN BASS

During Fun Machine operation, Fun Bass circuitry must supply the bass divider with the correct signal frequencies in several modes of operation: In Fun Machine organ mode, the chord root frequency only is supplied to the divider. In non-Fun Bass rhythm modes of operation, root and fifth frequencies only are made available to the bass divider, and in Fun Bass mode, five of the chord frequencies are available to be gated to the bass divider input (IC17 pin 9). Of course, the divider must never receive two pitches at the same time.

FUN BASS THEORY (Cont'd.)

FUN BASS (Cont'd.)

Bass divider, IC17, is also used as the pedal divider on Model 127W and Model 128W organs. The Fun Machine push button switch, by switching +5V, accomplishes the changeover as follows: when switching to normal organ mode, +5V is removed from a bus which supplies: 1) the base of Q179; 2) power to part of the pedal logic circuit; and 3) Fun Machine keyswitch common voltage. As a result, Q179 now unclamps the pedal latch output and signal is applied to the pedal divider via level shifter Q180. Pedal logic open collector output stages IC25 and 26, now without power, are effectively non-existent, and Fun Machine keyswitch common voltage, also now missing, assures that all other Fun Machine circuits are inactive.

Generator signals gated by the Fun Machine chord selector IC's (IC3 thru IC14) are collected on common buses; root, major third, minor third, fifth, sixth, and seventh. The major and minor third signals are controlled by minor touch circuitry (to be discussed later) so that one or the other of these third signals will make up an output bus known as the "third bus". The chord output thus derived is controlled by normal Fun Machine circuits (See Fun Machine Theory in Technical Manual). These outputs are also supplied to the Fun Bass logic circuit.

The Fun Bass logic circuit contains two triple three input NAND gates with open collector outputs (type 7412). One input on each of five individual three input NAND gates receives signal from a chord selector output bus. (ie., root, third, etc.) Root signal is applied to pin 2 of IC26; third signal is applied to pin 4 of IC25; fifth signal is applied to pin 10 of IC26; sixth signal is applied to pin 1 of IC25; and seventh signal is applied to pin 4 of IC26. The outputs of these five three input NAND gates are connected together to form the output of the Fun Bass logic circuit. This output bus is connected to pin 9 (the clock input) of bass divider, IC17.

In order for the signal frequency to be gated by a typical three input NAND gate, it is necessary for the signal (square wave, 0, +5V) to be applied to one input and a high logic level (+5V) to the two other inputs. For instance, in root only mode of operation, pin 1 and pin 13 of IC26 must both be high. With these conditions met, the root signal (applied to pin 2) will be inverted by IC26 and appear at the output. It is also a circuit requirement that the other four available bass pitches be defeated. Any signal applied to a three input NAND gate input, along with a low logic level at, at least one other input, is inhibited. These conditions are met by the logic circuitry preceding the output stage of the Fun Bass logic circuit.

ROOT ONLY

Root only operation occurs only when ORGAN is selected alone. The Organ Switch supplies saturation voltage to the base of Q70. Q70 grounds the base of Q69, assuring that its collector can be pulled up to +5V, the high logic level. This high logic level is applied to pin 5 of two input NOR gate IC23 along with a wired low at the other input, pin 6. The combination of high and low at the input of the NOR gate results in a low output at pin 4. IC23 pin 4 is connected to IC26, pin 9, causing the fifth signal to be inhibited. This same low logic level is also applied to pin 11 of two input NOR gate IC23. Pin 12 of IC23 is also at the low logic level through a portion of the circuit yet to be described. NOR gate IC23 having both inputs at the low logic level supplies, at its output, a high logic level to pin 13 of IC26; which is part of the information necessary to gate the root signal.

Also necessary is the circuit path from the high logic level present at the collector of Q172. The collector of Q172 is high because no forward bias voltage, from a rhythm pattern switch, is present at its base. (Bias for Q172 is available only when a rhythm pattern with Fun Bass is selected.) The high collector of Q172 supplies the other necessary high logic level to pin 1 of IC26, allowing the root frequency to be gated. +5V at the collector of Q172 is also connected to pin 2 of IC23 along with the wired low logic level at pin 3. The output at pin 1 of IC23 is therefore low and is connected to IC26 pin 5, inhibiting the seventh.

The collector of Q178 is high (+5V) also, because no Fun Bass rhythm select switch is on. Inputs to NOR gate IC23 are therefore +5 at pin 8 (from Q178 collector) and a wired low at pin 9 causing the output to be low. The low logic level at IC23 pin 10 inhibits the sixth and the third by supplying a low logic level to IC25 pin 3 and 13. IC23 pin 12 also receives the low logic level from IC23 pin 10 and along with the previously discussed low input at pin 11 causes a high logic level to be at its output, pin 13. The high logic level from pin 13 is connected to IC26 pin 13 completing the logic requirements for gating the root of the chord.

NOTE: Portions of the circuit that are irrelevant to Root Only operations have not been discussed.

ROOT/FIFTH

Root/fifth is the normal Fun Machine bass pattern. That is, a root bass frequency may be triggered one or more times in the first half of each measure, and a fifth bass frequency in the second half of each measure. The timing of the pulses, which sound the bass notes, is determined by the rhythm pattern selected. Rhythms to which Fun Bass can be added play a root/fifth pedal pattern when Fun Bass is cancelled.

In any rhythm mode, outputs from the Rhythm Voice board initiate the switching of the bass logic circuits that determine which of the five available frequencies are supplied to the bass divider. In the case of any root/fifth mode of operation, a single input from the Rhythm Voice board determines whether a root or a fifth will be the bass frequency. In all 4/4 rhythms, counter output A3 (IC2 pin 12) supplies information the pedal logic circuit that determines when the circuit output switches between root and fifth. In Waltz mode, A4 (IC2 pin 13) supplies this information. During the first half of each measure, A3 is at the high logic level. This voltage causes Q41 to be cut-off and, therefore, supplies no voltage to the base of Q69 on the Fun Machine logic board. When Q69 is in the cut-off state, the Fun Bass logic circuit supplies a root frequency to the pedal divider as previously discussed under Organ Mode. In the second half measure, counter output A3 is at the low logic level, forcing Q41 to saturate and supply +27V to Q69. The collector of the now saturated Q69 supplies a low logic level, resulting in the following action: Pin 5 of NOR gate IC23 is now low along with the wired low at pin 6, resulting in a change from low to high logic level at output pin 4. This change in logic level affects two other points: The high logic level at pin 11 of IC23 causes the output of this NOR gate, at pin 13, to switch, going from high to low, and because of its connection to pin 13 of IC26, the root frequency is now defeated. And at the same time, the high logic level from pin 4 of IC23 is applied to pin 9 of IC26, completing the necessary input logic level requirements needed to gate the fifth signal to the pedal divider.

When a 3/4 time rhythm pattern has been selected, Q41 is controlled by counter output A4 which switches only at the end of each measure. As a result, 3/4 time rhythm patterns play root base frequencies in the first measure and fifth bass frequencies in the second measure, etc.

Rhythm patterns with Fun Bass capability are identified by a black dot on the associated push button switch. The Fun Bass switch controls the bases of three PNP transistors, Q185, Q186, and Q173. When Fun Bass is cancelled, these transistor bases are held at +27V and cannot respond to any input. When Fun Bass is desired, clamping voltage is removed by the switch and the transistors are then able to respond to control voltage.

Typical Fun Bass circuit operation: Swing

The Swing push button switch contacts simultaneously supply strobe pulses to pin 3 of the ROM and +27V to the Fun Bass logic circuit. (Rhythm circuit theory is covered in all Fun Machine manuals.) +27V supplied by the Swing switch is connected to the emitters of Q185 and Q186, providing the voltage which will be applied to the Fun Bass logic circuit when the associated rhythm counter output is at its low logic level (+12V). The switched +27V also saturates Q175 and Q174. Q175 then supplies a low at IC22 pin 13 and Q174 causes Q173 to be forward biased so that the Cymbal trigger will also trigger the Bass Guitar.

At the beginning of a measure, all counter outputs are set high and the Swing rhythm pattern memory information supplies a Bass Guitar trigger. At the 1st count of the measure, the Fun Bass logic circuit is supplying the root frequency to the bass divider. (Same circuit configuration as previously explained in the ROOT ONLY SECTION.) As the measure progresses, during the 2nd, 3rd, and 4th counts, no ROM trigger output is programmed for the Bass Guitar or Cymbal circuits and the counter outputs A2, A3, and A4, which control the Fun Bass logic, do not change. At count 5, the A2 counter output changes to the low logic level. (See Real Rhythm logic waveform chart.) When A2 goes low, Q186 is switched on (saturated) supplying saturation bias for Q178. Saturation of Q178 now supplies a low to NOR gate IC23 pin 8 which along with the wired low at pin 9, causes a high to be applied from output pin 10 to IC23 pin 12. NOR gate IC23 pins 12 and 11, now has a high and a low at its input terminals and the resulting low output at pin 13 defeats the root by supplying a low to NAND gate IC26 pin 13. The high from IC23 pin 10 also supplies part of the necessary logic needed to gate the 3rd by its connection to IC25 pins 3 and 13 (the 3rd must be gated at count #5). In order to gate the 3rd signal, one additional high must be applied to IC25 pin 5. Since pin 5 is supplied by the output of an inverter stage (IC25 pin 8), it is necessary that the input to the inverter (IC25 pins 9, 10, and 11) be low and referring to the Fun Machine chord logic schematic it can be seen that this necessary low logic level also defeats the 6th by its connection to IC25 pin 2. This required low logic level is supplied by NAND gate output IC24 pin 6. Pins 4 and 5 of IC24 must now be high. The necessary high logic levels for IC24 pins 4 and 5 come from two additional NAND gates in IC24 with outputs at pins 3 and 8. Inputs controlling pins 3 and 8 (NAND gate outputs) are the previously explained low logic levels from IC23 pins 1 and 4 which are connected to IC24 pins 2 and 9 respectively, assuring the necessary highs at pins 3 and 8 of IC24.

The preceding establishes that the 3rd signal is now being applied to the bass divider. In order to sound this frequency, a trigger from the Cymbal circuit is conducted via D262 & Q173 to Bass Guitar trigger transistor Q71. The Cymbal trigger is utilized at this count because the Swing ROM program does not include a Bass Guitar trigger at this point in the measure.

As the measure continues through count 6, 7 and 8, the 3rd continues to be applied to the bass divider but no additional Bass Guitar or Cymbal trigger comes from the ROM and so during this time, no bass note is heard. At count 9, both A2 and A3 counter outputs change state and set up the circuit for gating the 5th as previously discussed under Root/Fifth. The Bass Guitar is now triggered by both sources - Bass trigger and Cymbal trigger.

FUN BASS THEORY (Cont'd.)
ROOT/FIFTH (Cont'd.)

Continuing through the measure, no Bass or Cymbal ROM output is programmed until count 13. At count 13, counter output A2 switches low and causes voltage to be applied to the base of Q178, the resulting level change at the collector causes the associated logic circuitry to apply the 6th to the bass divider and the Cymbal trigger will sound this bass note.

Each succeeding change in the 3 counter outputs connected to the bass logic circuit cause one of the five available bass frequencies to be applied to the pedal divider at the time required by the rhythm pattern selected.

Swing and Dixieland have similar "walking bass" patterns when in Fun Bass mode. The other five Fun Bass patterns: Country, Pop Rock, Hawaiian, Rhumba, and Polka add a "3rd" to the normal root/fifth pedal patterns. Control voltage (+27V) from the rhythm pattern switches is applied, as in Swing and Dixieland, to Q185 and Q186 emitters, and to the base of Q176 which cuts off Q177. The collector of Q177 now switches to the high logic level and allows NAND gate IC22 pins 4, 5, and 6 to become active. Thus, when A3 is high the operation of Q172 in response to A4 is inhibited by the low at IC22 pin 6. The result of this action is that a normal root/fifth pattern is heard during the first measure of these rhythms and an extra bass note (3rd) is added to the second measure.

FUN BASS RHYTHM PATTERNS	RHYTHM COUNT	INPUT ADDRESS			SECONDARY ADDRESS			GATED 3-INPUT NAND GATE		OUTPUT SIGNAL BUS
		A2	A3	A4	Q178c	Q69c	Q172c	INPUT	OUTPUT	
SWING	1-4	H	H	H	H	H	H	IC26-1&13@H	IC26-12	ROOT
DIXIELAND	* 5-8	L	H	H	L	H	H	IC25-3&5@H	IC25-6	THIRD
POP ROCK		9-12	H	L	H	H	L	H	IC26-4&9@H	IC26-8
RHUMBA	*13-16	L	L	H	L	L	H	IC25-2&13@H	IC25-12	SIXTH
COUNTRY	17-20	H	H	L	H	H	L	IC26-3&5@H	IC26-6	SEVENTH
HAWAIIAN	21-24	L	H	L	L	H	L	IC25-2&13@H	IC25-12	SIXTH
POLKA	25-28	H	L	L	H	L	L	IC26-4&9@H	IC26-8	FIFTH
	29-32	L	L	L	L	L	L	IC25-3&5@H	IC25-6	THIRD
DIXIELAND Other beats POP ROCK as in RHUMBA Swing	5-8	L	H	H	(H) ¹	H	H	INHIBITS 3rd BUS		ROOT.
	13-16	L	L	H	(H) ¹	L	H	INHIBITS 6th BUS		FIFTH
POP ROCK Other beats as in RHUMBA Swing	17-20	H	H	L	H	H	(H) ²	INHIBITS 7th BUS		ROOT
	21-24	L	H	L	(H) ¹	H	(H) ²	INHIBITS 6th BUS		ROOT

(H)¹ - Changed from "L" to "H" by "L" @ IC22-11. 3 - All have same Fun Bass count

(H)² - Changed from "L" to "H" by "L" @ IC22-6.

ROOT/FIFTH LOGIC SELECTION CHART

MINOR TOUCH THEORY

In all W series organs, 121W, 123W, 127W, and 128W, the mechanical switch operated minor bar has been replaced with a body capacity operated "touch strip". The minor touch action is identical to the previous system (changes the major 3rd in the chord to a minor 3rd), but is accomplished through different means.

Both the major and minor 3rd pitches are always gated by the action of chord selector logic. Normally, the major 3rd is included in the chord and the minor 3rd is inhibited. When the touch strip is activated, the major 3rd is inhibited and the minor 3rd is included in the chord. A single bus, known as the 3rd bus, carries the output signal.



Minor touch circuitry consists of a capacity touch strip on the accompaniment manual keyslip connected to the minor touch strip interface circuit assembly located on a small P.C. board mounted on the accompaniment keyframe directly behind the accompaniment bass keycap. A single shielded line from the P.C. board provides control for major - minor 3rd logic circuit on the Fun Machine logic board.

Control of the 3rd bus is accomplished by two 2 input NAND gates in IC22 (see Fun Machine logic schematic) and an additional NAND gate wired to function as an inverter. Major 3rd signal is connected to IC22-1 and the minor 3rd signal is connected to IC22-9. The major 3rd signal (0, +5V square wave) and the minor touch control bus form the input to a NAND gate. When the control bus is high, the minor 3rd signal is inverted by the NAND gate and appears on the 3rd bus. The high minor touch control bus is also inverted and applied to the NAND gate controlling the minor 3rd, this now inhibits the minor 3rd. When the minor touch strip is activated, the control bus switches low to defeat the major 3rd, and is inverted by IC24 pin 12, 13, and 11, to gate the minor 3rd.

The Minor Touch Strip Interface circuit includes a 100kHz oscillator, the output of which is connected to the inner foil of the Touch Strip and the emitter of Q181. The base of Q181 is also connected to the oscillator output by two series diodes, D274 and D275. The junction of the two diodes is connected to the outer foil of the touch strip. When the strip is touched, capacity to ground is added to the circuit. The capacity to ground at the junction of D274 and D275 allows this point to become positive enough to cut off Q181, which allows Q182 to saturate. The collector of Q182 now drops to approximately .7V, resulting in the cut off of previously saturated Q183. The collector of Q183 now allows Q184 to be saturated via R923. The low collector of Q184 now, through two inverter stages in IC27, supplies a low on the minor touch control bus, resulting in a minor 3rd being substituted in the chord being played.



128-2

TYPICAL LATCHING SWITCH
SHOWN IN NORMALLY OFF POSITION

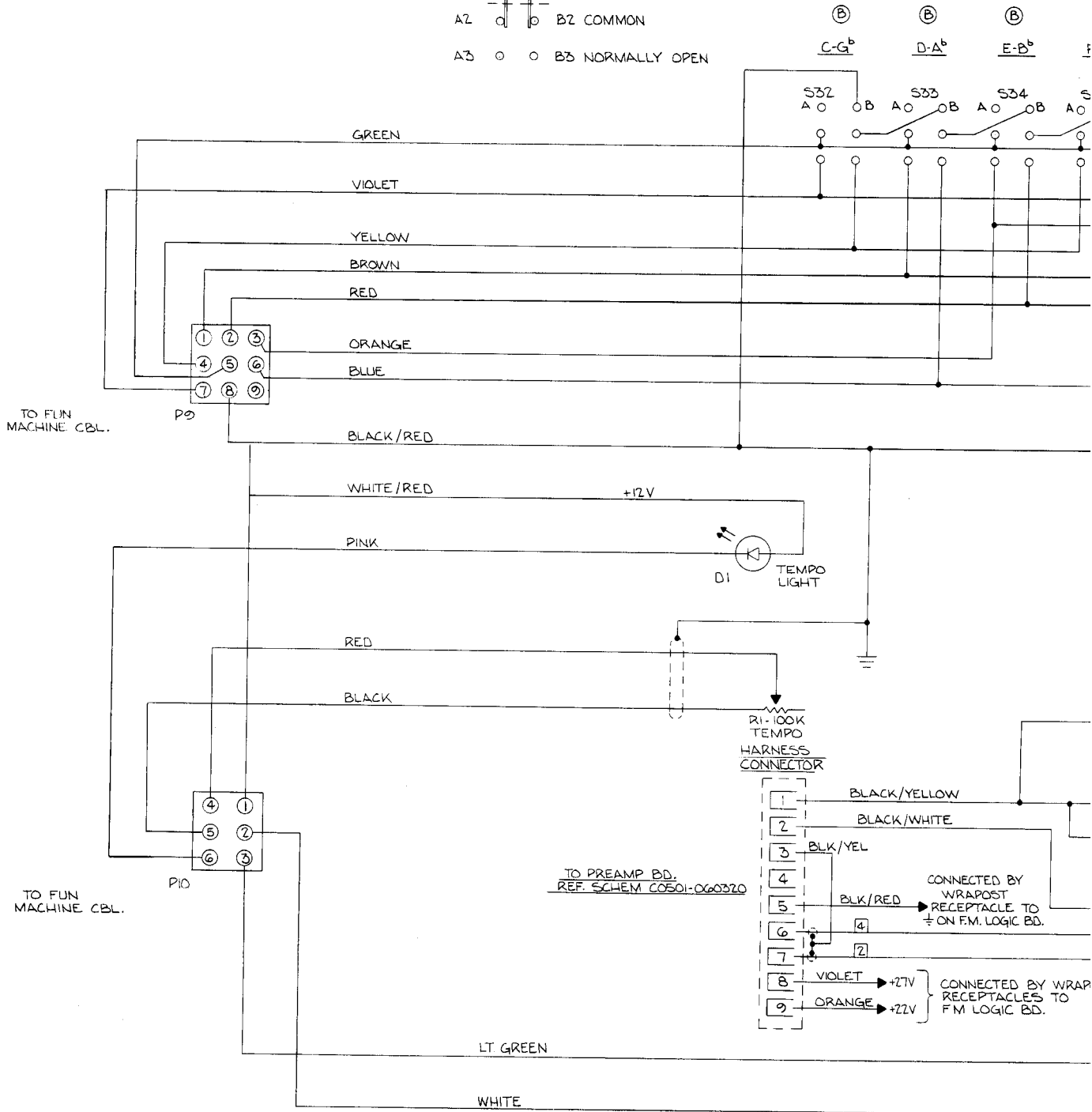
A1  B1 NORMALLY CLOSE
 A2  B2 COMMON
 A3  B3 NORMALLY OPEN



NOTES:

1.  INDICATES BLUE PUSH BUTTON INSERT.
2. TWO SEPERATE GROUNDS :
 GENERAL GROUND
 SIGNAL GROUND
3. REF. SCHEMATICS :
 F.M. LOGIC BD. - ROS01-100779
 F.M. RHYTHM VOICE BD - ROS01-100461
 F.M. RIGHT HAND VOICE BD - ROS01-060699.

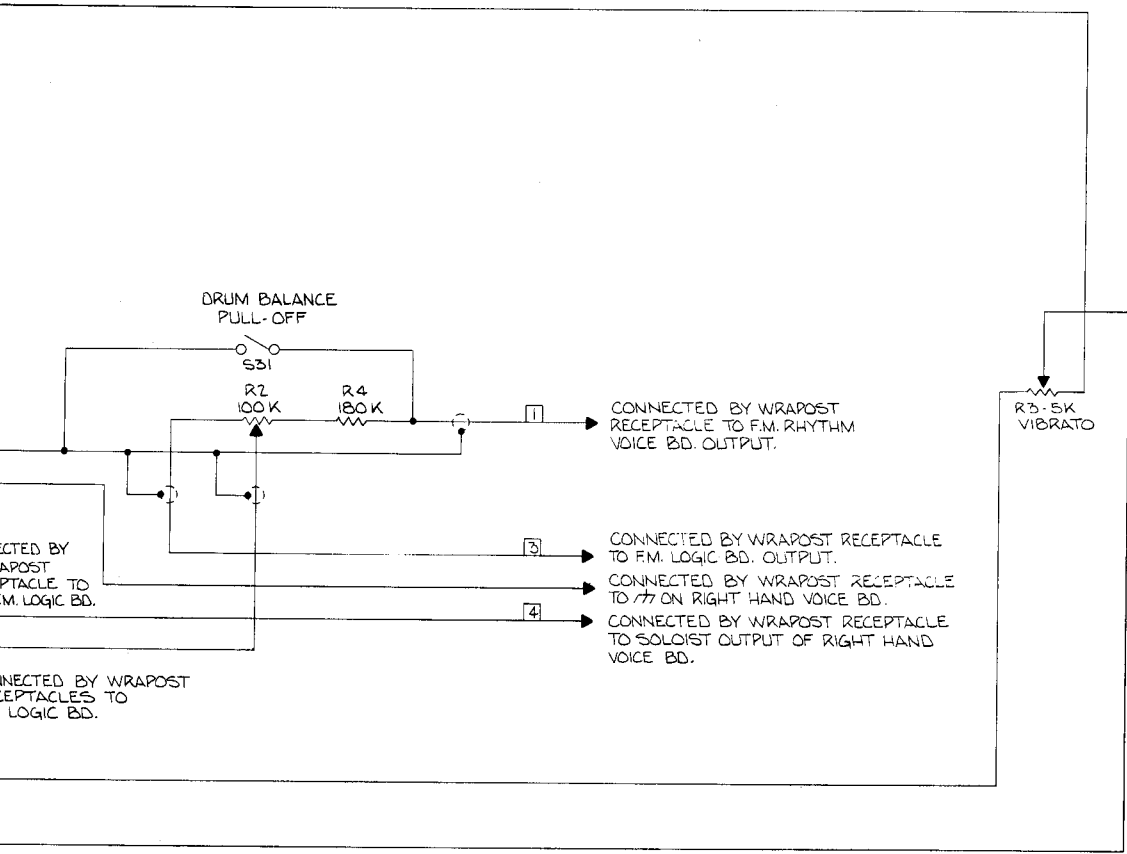
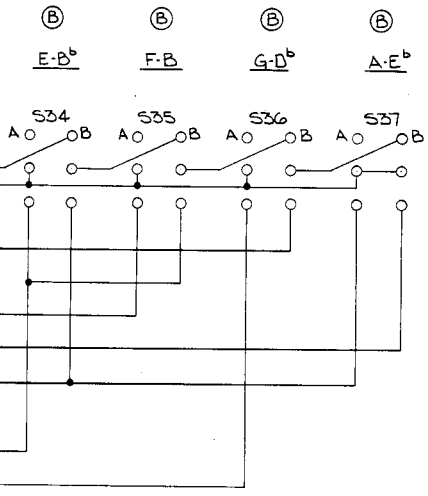

COMPONENTS		LAST N ^o	DATE	OWN.	CH'D.	APP'D.	DWL. SCALE	USED ON	PART NAME
RESISTORS	R4	R4	6-2-77	BEALS	RPB	ALS	12.5W	REQ.	SCHEM, KEY SELECTOR KEYCAP
PLUGS	P10	P10						FINISH	B/M 503-12W-15 GR. NOTED IT.
SWITCHES	S37	S37						NEXT ASSEM.	SUPERSEDES
DIODE (L.E.D)	D1	D1							BALDWIN PIANO & ORGAN CO. CINCINNATI, OHIO

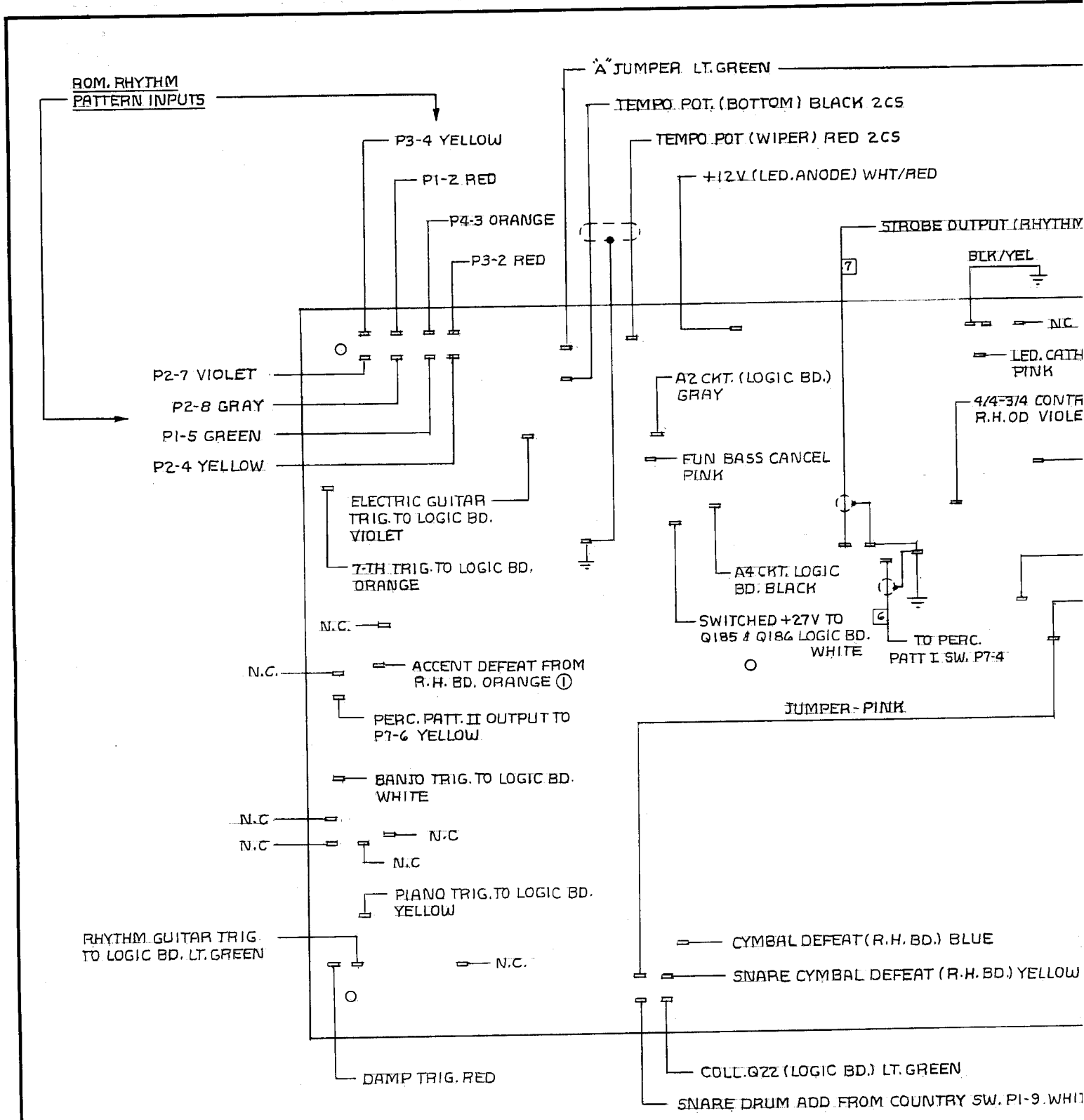

REF. SCHEM- R501-100461

DATE	8-31-78	DWN.	D. PEALE
PRINT	CIN.	GR.	
DISTRIBUTION	5		
<small>ALL DRAWINGS AND SPECIFICATIONS ARE AND BE RETURNED TO IT. ALL SPECIFICATIONS ARE CONFID TO WHOM THEY ARE SENT. NO DRAWINGS SPECIF WHICH MAY BE FURNISHED TO MANUFACTURERS OTHERWISE AS IN ANY MANNER LICENSED THE NO OR PERMISSION TO MANUFACTURE, USE OR SELL</small>			
<small>UNLESS OTHERWISE SPECIFIED TOLERAN</small>			

RELEASED

Ord. No. CN. 18,030
Date 8/31/78

RECORD OF CHANGE

JUMPER LT. GREEN

MPO. POT. (BOTTOM) BLACK 2C5

TEMPO. POT (WIPER) RED 2C5

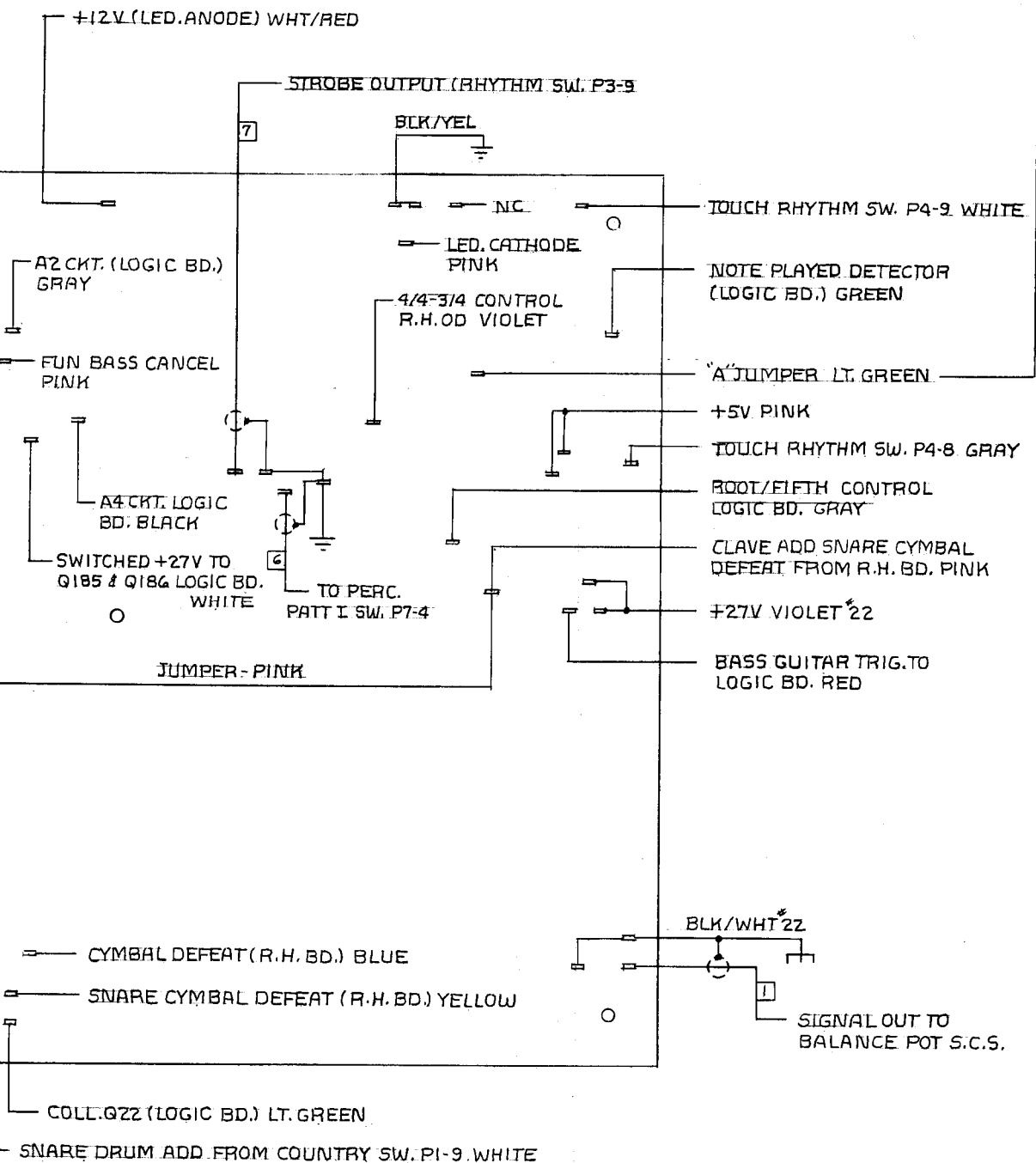

DATE 8-31-78	DWN. D. PEALE	CHKD. <i>[Signature]</i>	APP'D. <i>[Signature]</i>	DWN. SCALE FULL	USED ON 121W	PART NAME <u>BD. RHYTHM VOICE</u>	
PRINT DISTRIBUTION 5	CIN.	GR.	CON.	FAY. 281-187	DEQ. 372	E.P.T.	
ALL DRAWINGS AND SPECIFICATIONS ARE AND REMAIN THE PROPERTY OF THE BALDWIN PIANO & ORGAN CO. AND MUST BE RETURNED TO IT. ALL SPECIFICATIONS ARE CONFIDENTIAL AND ARE NOT TO BE DISCLOSED TO ANY PERSONS OTHER THAN THOSE TO WHOM THEY ARE SENT. NO DRAWINGS, SPECIFICATIONS OR OTHER DATA BELONGING TO THE BALDWIN PIANO & ORGAN CO. WHICH MAY BE FURNISHED TO MANUFACTURERS OR OTHERS FOR ANY PURPOSE ARE TO BE REGARDED BY IMPLICATION OR OTHERWISE AS IN ANY MANNER LICENSING THE HOLDER OR ANY OTHER PERSON OR CORPORATION OR CONVEYING ANY RIGHTS OR PERMISSION TO MANUFACTURE, USE OR SELL ANY PATENTED INVENTION THAT MAY IN ANY WAY BE RELATED THERETO.						REQ.	FINISH B/M 121W-17 GR. NOTED IT.
UNLESS OTHERWISE SPECIFIED TOLERANCES ARE: DECIMAL ±.005 FRACTIONAL ±.015 ANGLE ±1/2°						NEXT ASSEM.	SUPERSEDES
BALDWIN PIANO & ORGAN CO. CINCINNATI, OHIO						C 0501-103074	REV.

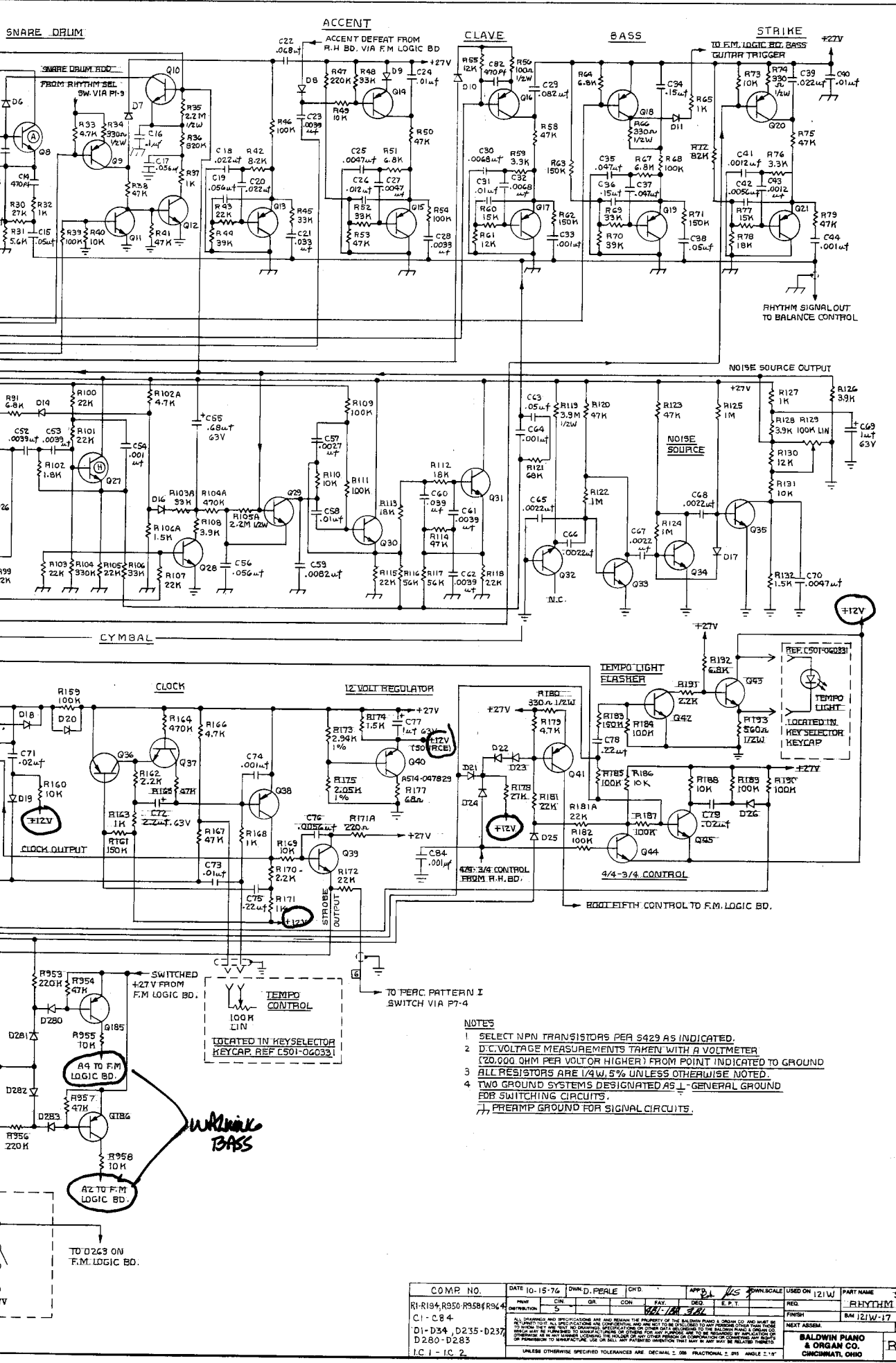

RELEASED
 Ord. No. C.N. 872
 Date 11/1/79

RECORD OF CHANGE

A) ADDED CIRCUIT CONNECTION DOTS. C.N. 1715B 2-14-77

B) ADDED R964. C17 WAS TO PREAMP GROUND. RELOCATED C84. C.N. 17376 6-21-77

C) MADE COMPONENT NUMBER CORRECTIONS C.N. 17,658 11-22-77

D) R6 WAS 220K. R171A, R174, R177, R194 WERE 1/2W. C118, C12 DP 10-13-78

- NOTES
- 1 SELECT NPN TRANSISTORS PER 5429 AS INDICATED.
 - 2 D.C. VOLTAGE MEASUREMENTS TAKEN WITH A VOLTMETER (20,000 OHM PER VOLT HIGHER) FROM POINT INDICATED TO GROUND
 - 3 ALL RESISTORS ARE 1/4W, 5% UNLESS OTHERWISE NOTED.
 - 4 TWO GROUND SYSTEMS DESIGNATED AS \perp - GENERAL GROUND FOR SWITCHING CIRCUITS. ∇ - PREAMP GROUND FOR SIGNAL CIRCUITS.

COMP. NO.	DATE 10-15-76	BY D.W.D. PERLE	CHKD.	APP'D.	SCALE 1/2" = 1"	USED ON 121W	PART NAME	SCHEM.
R1-R184, R195-R198, R194							RHYTHM SECTION VOICE BD.	
C1 - C84							BA 121W-17	OR NOTE
D1-D34, D235-D237								
D280-D283								
IC 1 - IC 2								

UNLESS OTHERWISE SPECIFIED TOLERANCES ARE DECIMAL 2.0% FRACTIONAL 2.0% ANGLE 2.0°

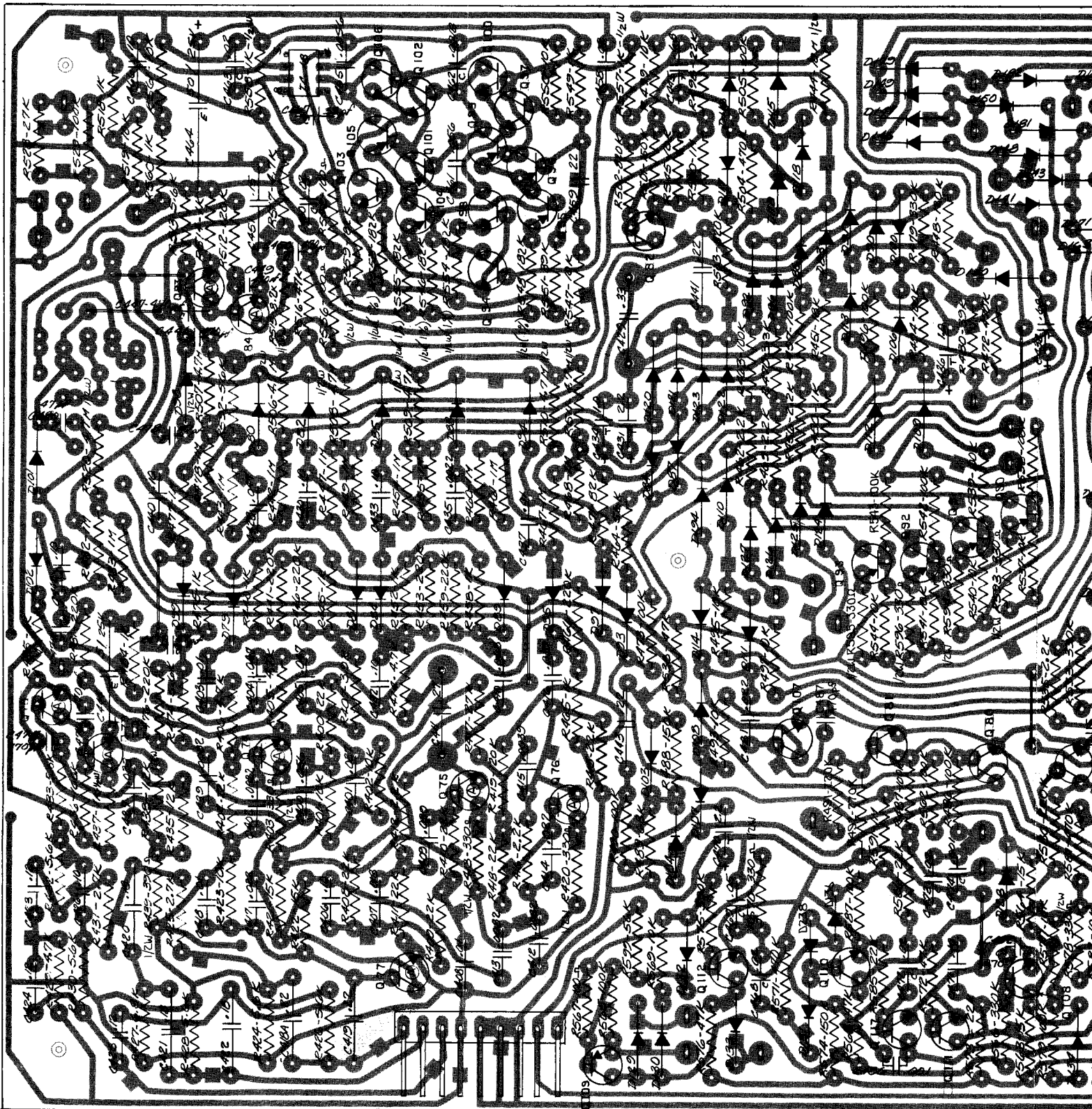

NOTES:

- 1) SELECT NPN TRANSISTORS Q74, Q75, Q76, Q77, Q78, Q79, Q83, Q84, PER S429-A
 Q96 & Q99 - Q97 & Q100 - Q101 & Q105 - Q106 & Q102 ARE MATCHED FOR BASE-EMITTER DROP PER S627.
- 2) ALL DIODES ARE MEDIUM VOLTAGE 1S14-042791 (17, 74)
- 3) REFERENCE SCHEMATIC - R501-06069D (12W) R501-061056 (127W/28W) R501-06111A (28R)
- 4) PIN WIRING DIAGRAM - C501-100992 (121W) C501-061113 (127W/28W) C501-061451 (28R)
- 5) FINAL ASSY TO INCLUDE PART No 500-060663 3

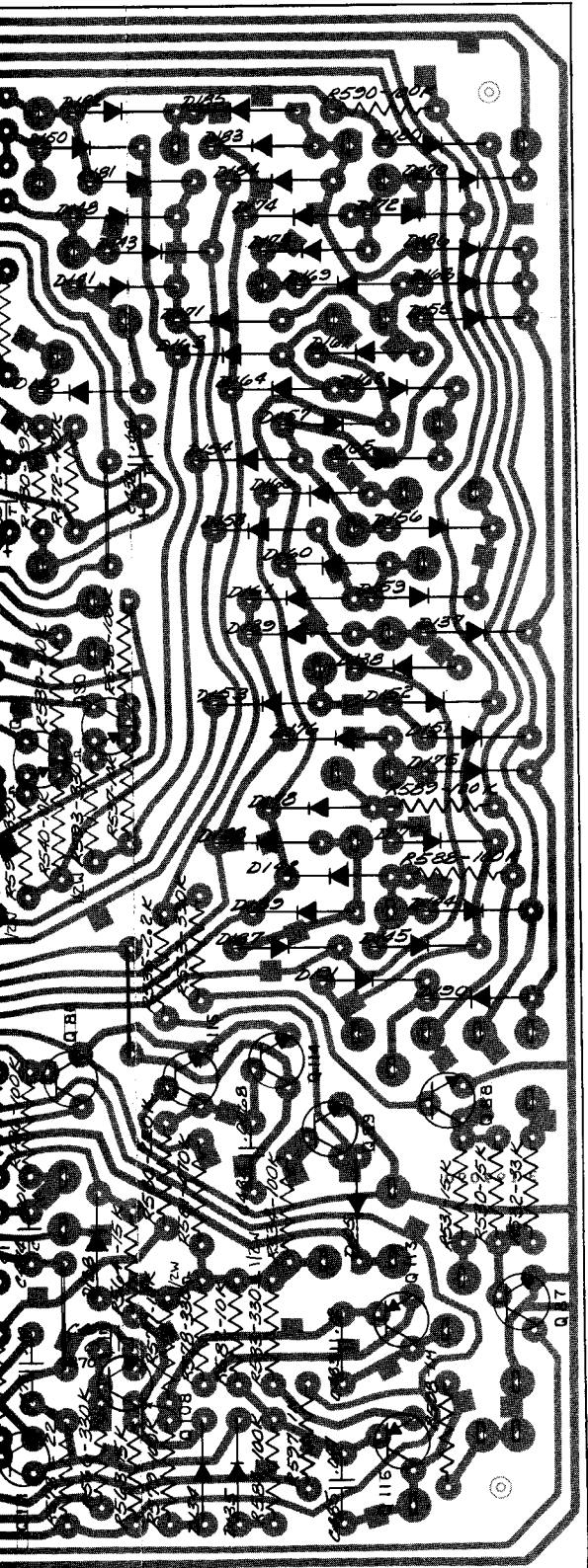

LEGEND:
 "C" DENOTES CERAMIC CAPACITOR
 "T" DENOTES TANTALUM CAPACITOR
 "E" DENOTES ELECTROLYTIC CAPACITOR

RELEASED
 Ord. No. R.M. 650
 Date 1/28/74

RECORD OF CHANGE

① REDRAWN 2 TIMES SIZE. NO CHANGE NO CH 9-5-74 KMB

E) C 482 WAS 330PF QTY OF ITEM 70 WAS 6 CH 16,092 DP 10-29-74

E) ADDED NOTE 1 C.N. 16,540 D.R.B. 1-14-76

G) ALL RESISTORS WERE 5239 1/2W 10% R437, R557 & R558 NOT CHANGED C.N. 14,532 1-30-76 RML

H) IT. 38 PART NO. WAS 5243-1903 CH 16,872 11-12-76

② DELETED R434. ADDED C487. C.N. 17,118 2-17-77 RH

ITEM	REQ	PART NO.	PART NAME
85			
84			
83	13	5250-102	RESISTOR 1/4W 5% 1K
82	1	5239-102-10	RESISTOR 1/2W 10% 8.2K
81	X	5184-3	SOLDER (DIP)
80	X	5184-4	SOLDER (IRON)
79	X	5187-4	WIRE #22 BARE COPPER
78	1	AS14-053281	OPERATIONAL AMPLIFIER
77	1	AS14-053127	CONNECTION (3 CONN.)
76	23	AS14-033338	TRANSISTOR, NPN
75	13	AS14-044510	TRANSISTOR, PNP
74	16	AS14-042791	DIODE, MEDIUM VOLTAGE
73	1	5218-503	CAPACITOR CERAMIC .05uF
72	6	5205-203	
71	2	102	.02uF
70	8	471	.470uF
69			
68			
67	4	470	.47uF
66	1	5205-330	CERAMIC .33uF
65	1	5211-025-050	ELECT. 50uF 25V
64	1	5211-025-005	ELECT. 5uF 25V
63	2	5244-25-225-1	TANT. 2.2uF
62	2	5244-35-105-2	TANT. 1uF
61	2	5244-35-684-1	TANT. .68uF
60	1	5232-01-334	MYLAR .33uF
59	1	274	.27uF
58	5	224	.22uF
57	3	184	.18uF
56	1	154	.15uF
55	4	124	.12uF
54	3	104	.10uF
53	1	683	.068uF
52	2	563	.056uF
51	4	473	.047uF
50	2	393	.039uF
49	1	333	.033uF
48	1	273	.027uF
47	3	223	.022uF
46	1	183	.018uF
45	4	103	.010uF
44	3	822	.0082uF
43	1	682	.0068uF
42	1	562	.0056uF
41	1	392	.0039uF
40	2	222	.0022uF
39	1	5232-01-182	CAPACITOR, MYLAR .0018uF
38	6	3332-001823	RESISTOR 1/2W 1% 182K
37	1	5239-102-10	RESISTOR 1/2W 10% 10M
36	7	5239-475-10	1/2W 10% 4.7M
35	18	5250-105	1/4W 5% 1M
34	2	824	820K
33	4	474	470K
32	1	394	390K
31	3	334	330K
30	1	274	270K
29	3	224	220K
28	3	154	150K
27	3	124	120K
26	24	104	100K
25	1	823	82K
24	1	683	68K
23	3	563	56K
22	5	473	47K
21	2	393	39K
20	1	333	33K
19	2	273	27K
18	12	223	22K
17	1	183	18K
16	6	153	15K
15	1	123	12K
14	19	103	10K
13	1	682	6.8K
12	8	562	5.6K
11	5	472	4.7K
10	1	392	3.9K
9	1	332	3.3K
8	2	272	2.7K
7	6	5250-222	1/4W 5% 2.2K
6	1	5239-122-10	1/2W 10% 1.2K
5	3	102	1K
4	1	391	390Ω
3	10	331	330Ω
2	3	5239-101-10	RESISTOR 1/2W 10% 100Ω
1	1	5205-060-662	R.H. VOICE B'D RIVETER

DATE 9-9-74 OWN. READY (checked) 9-17-74 APPD. Bal. (checked) CHN. SCALE 2:1 USED ON 121W 437W 128W PART NAME RIGHT HAND VOICE B'D ASSEMBLY

PRINT CEN. GR. CON. 1. PAY. DEL. E.P.T. FINISH BAI 503-121W-17 GR. 5 IT.

ALL DRAWINGS AND SPECIFICATIONS ARE AND REMAIN THE PROPERTY OF THE BALDWIN PIANO & ORGAN CO. AND MUST BE RETURNED TO IT. ALL SPECIFICATIONS ARE CONFIDENTIAL AND ARE NOT TO BE DISCLOSED TO ANY OTHER PERSON OR ORGANIZATION WITHOUT THE WRITTEN PERMISSION OF THE BALDWIN PIANO & ORGAN CO. THIS DRAWING IS THE PROPERTY OF THE BALDWIN PIANO & ORGAN CO. AND IS NOT TO BE REPRODUCED OR TRANSMITTED IN ANY FORM OR BY ANY MEANS, ELECTRONIC OR MECHANICAL, INCLUDING PHOTOCOPYING, RECORDING, OR BY ANY INFORMATION STORAGE AND RETRIEVAL SYSTEM, WITHOUT THE WRITTEN PERMISSION OF THE BALDWIN PIANO & ORGAN CO. UNLESS OTHERWISE SPECIFIED TOLERANCES ARE: DECIMAL 2.0% FRACTIONAL 2.0% ANGLE 2.1°

NEXT ASSY. 500-100750 SUPERSEDED

BALDWIN PIANO & ORGAN CO. CINCINNATI, OHIO

D 500-060663

RELEASED
 Ord. No. CN 16,872
 Date 11/15/76
 RECORD OF CHANGE
 A REVERSED P3-7 &
 P4-1 CN. 17,158
 2-14-77 JAB

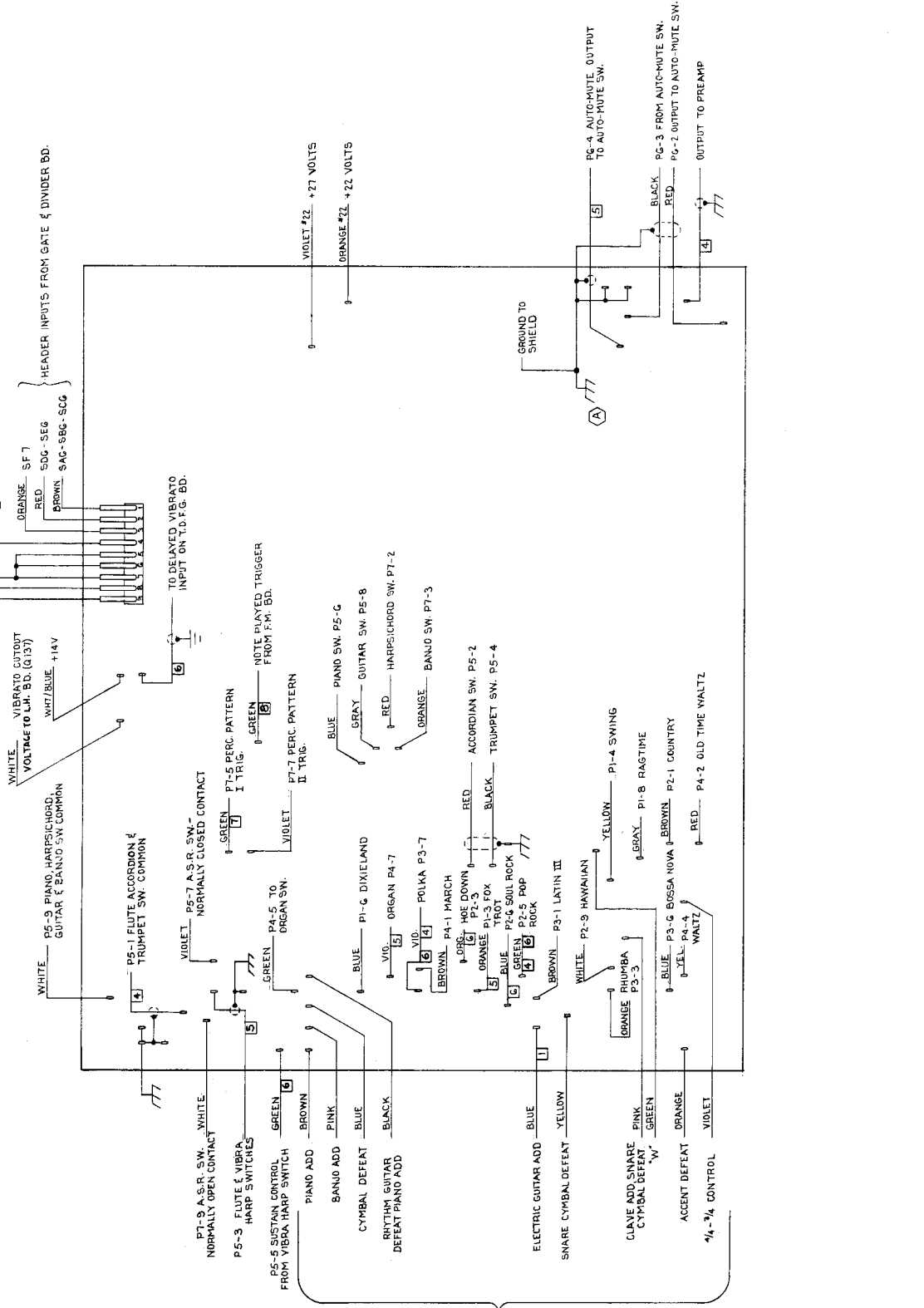

DATE	11-14-76	BY	CH	APP'D.	SCALE	USED ON	121W	PART NAME	RIGHT HAND BOARD
REV.	1	GR.	CON.	1	REV.	REC.	121W	PIN WIRING DIAGRAM	
REV.	2	GR.	CON.	1	REV.	FINISH	121W	PIN WIRING DIAGRAM	
REV.	3	GR.	CON.	1	REV.	FINISH	121W	PIN WIRING DIAGRAM	
REV.	4	GR.	CON.	1	REV.	FINISH	121W	PIN WIRING DIAGRAM	
REV.	5	GR.	CON.	1	REV.	FINISH	121W	PIN WIRING DIAGRAM	
REV.	6	GR.	CON.	1	REV.	FINISH	121W	PIN WIRING DIAGRAM	
REV.	7	GR.	CON.	1	REV.	FINISH	121W	PIN WIRING DIAGRAM	
REV.	8	GR.	CON.	1	REV.	FINISH	121W	PIN WIRING DIAGRAM	
REV.	9	GR.	CON.	1	REV.	FINISH	121W	PIN WIRING DIAGRAM	
REV.	10	GR.	CON.	1	REV.	FINISH	121W	PIN WIRING DIAGRAM	
REV.	11	GR.	CON.	1	REV.	FINISH	121W	PIN WIRING DIAGRAM	
REV.	12	GR.	CON.	1	REV.	FINISH	121W	PIN WIRING DIAGRAM	
REV.	13	GR.	CON.	1	REV.	FINISH	121W	PIN WIRING DIAGRAM	
REV.	14	GR.	CON.	1	REV.	FINISH	121W	PIN WIRING DIAGRAM	
REV.	15	GR.	CON.	1	REV.	FINISH	121W	PIN WIRING DIAGRAM	
REV.	16	GR.	CON.	1	REV.	FINISH	121W	PIN WIRING DIAGRAM	
REV.	17	GR.	CON.	1	REV.	FINISH	121W	PIN WIRING DIAGRAM	
REV.	18	GR.	CON.	1	REV.	FINISH	121W	PIN WIRING DIAGRAM	
REV.	19	GR.	CON.	1	REV.	FINISH	121W	PIN WIRING DIAGRAM	
REV.	20	GR.	CON.	1	REV.	FINISH	121W	PIN WIRING DIAGRAM	
REV.	21	GR.	CON.	1	REV.	FINISH	121W	PIN WIRING DIAGRAM	
REV.	22	GR.	CON.	1	REV.	FINISH	121W	PIN WIRING DIAGRAM	
REV.	23	GR.	CON.	1	REV.	FINISH	121W	PIN WIRING DIAGRAM	
REV.	24	GR.	CON.	1	REV.	FINISH	121W	PIN WIRING DIAGRAM	
REV.	25	GR.	CON.	1	REV.	FINISH	121W	PIN WIRING DIAGRAM	
REV.	26	GR.	CON.	1	REV.	FINISH	121W	PIN WIRING DIAGRAM	
REV.	27	GR.	CON.	1	REV.	FINISH	121W	PIN WIRING DIAGRAM	
REV.	28	GR.	CON.	1	REV.	FINISH	121W	PIN WIRING DIAGRAM	
REV.	29	GR.	CON.	1	REV.	FINISH	121W	PIN WIRING DIAGRAM	
REV.	30	GR.	CON.	1	REV.	FINISH	121W	PIN WIRING DIAGRAM	
REV.	31	GR.	CON.	1	REV.	FINISH	121W	PIN WIRING DIAGRAM	
REV.	32	GR.	CON.	1	REV.	FINISH	121W	PIN WIRING DIAGRAM	
REV.	33	GR.	CON.	1	REV.	FINISH	121W	PIN WIRING DIAGRAM	
REV.	34	GR.	CON.	1	REV.	FINISH	121W	PIN WIRING DIAGRAM	
REV.	35	GR.	CON.	1	REV.	FINISH	121W	PIN WIRING DIAGRAM	
REV.	36	GR.	CON.	1	REV.	FINISH	121W	PIN WIRING DIAGRAM	
REV.	37	GR.	CON.	1	REV.	FINISH	121W	PIN WIRING DIAGRAM	
REV.	38	GR.	CON.	1	REV.	FINISH	121W	PIN WIRING DIAGRAM	
REV.	39	GR.	CON.	1	REV.	FINISH	121W	PIN WIRING DIAGRAM	
REV.	40	GR.	CON.	1	REV.	FINISH	121W	PIN WIRING DIAGRAM	
REV.	41	GR.	CON.	1	REV.	FINISH	121W	PIN WIRING DIAGRAM	
REV.	42	GR.	CON.	1	REV.	FINISH	121W	PIN WIRING DIAGRAM	
REV.	43	GR.	CON.	1	REV.	FINISH	121W	PIN WIRING DIAGRAM	
REV.	44	GR.	CON.	1	REV.	FINISH	121W	PIN WIRING DIAGRAM	
REV.	45	GR.	CON.	1	REV.	FINISH	121W	PIN WIRING DIAGRAM	
REV.	46	GR.	CON.	1	REV.	FINISH	121W	PIN WIRING DIAGRAM	
REV.	47	GR.	CON.	1	REV.	FINISH	121W	PIN WIRING DIAGRAM	
REV.	48	GR.	CON.	1	REV.	FINISH	121W	PIN WIRING DIAGRAM	
REV.	49	GR.	CON.	1	REV.	FINISH	121W	PIN WIRING DIAGRAM	
REV.	50	GR.	CON.	1	REV.	FINISH	121W	PIN WIRING DIAGRAM	

TO RHYTHM & FUN MACHINE VOICE PROGRAMMING
 TO RHYTHM VOICE & F.M. LOGIC BOARDS

UNLESS OTHERWISE SPECIFIED TOLERANCES ARE: DECIMAL 2. DIG. FRACTIONAL 2. DIG. ANGLE 2.14"

ALL DIMENSIONS AND SPECIFICATIONS ARE AND SHALL BE THE PROPERTY OF BALDWIN PIANO & ORGAN CO. AND SHALL BE KEPT IN STRICT CONFIDENCE. ANY REPRODUCTION OR DISSEMINATION OF THIS INFORMATION TO ANY OTHER PARTY WITHOUT THE WRITTEN PERMISSION OF BALDWIN PIANO & ORGAN CO. IS PROHIBITED. THIS INFORMATION IS PROVIDED FOR YOUR INFORMATION ONLY. BALDWIN PIANO & ORGAN CO. IS NOT RESPONSIBLE FOR ANY DAMAGE TO PROPERTY OR PERSONS ARISING FROM THE USE OF THIS INFORMATION. THIS INFORMATION IS PROVIDED AS IS. BALDWIN PIANO & ORGAN CO. IS NOT RESPONSIBLE FOR ANY DAMAGE TO PROPERTY OR PERSONS ARISING FROM THE USE OF THIS INFORMATION.

DATE 11-14-76
 DWG. 121W
 PART NAME RIGHT HAND BOARD
 DIMENSIONAL SCALE USED ON 121W
 FINISH
 BALDWIN PIANO & ORGAN CO.
 CINCINNATI, OHIO
 SUPERSEDES
 C 501-10092 A

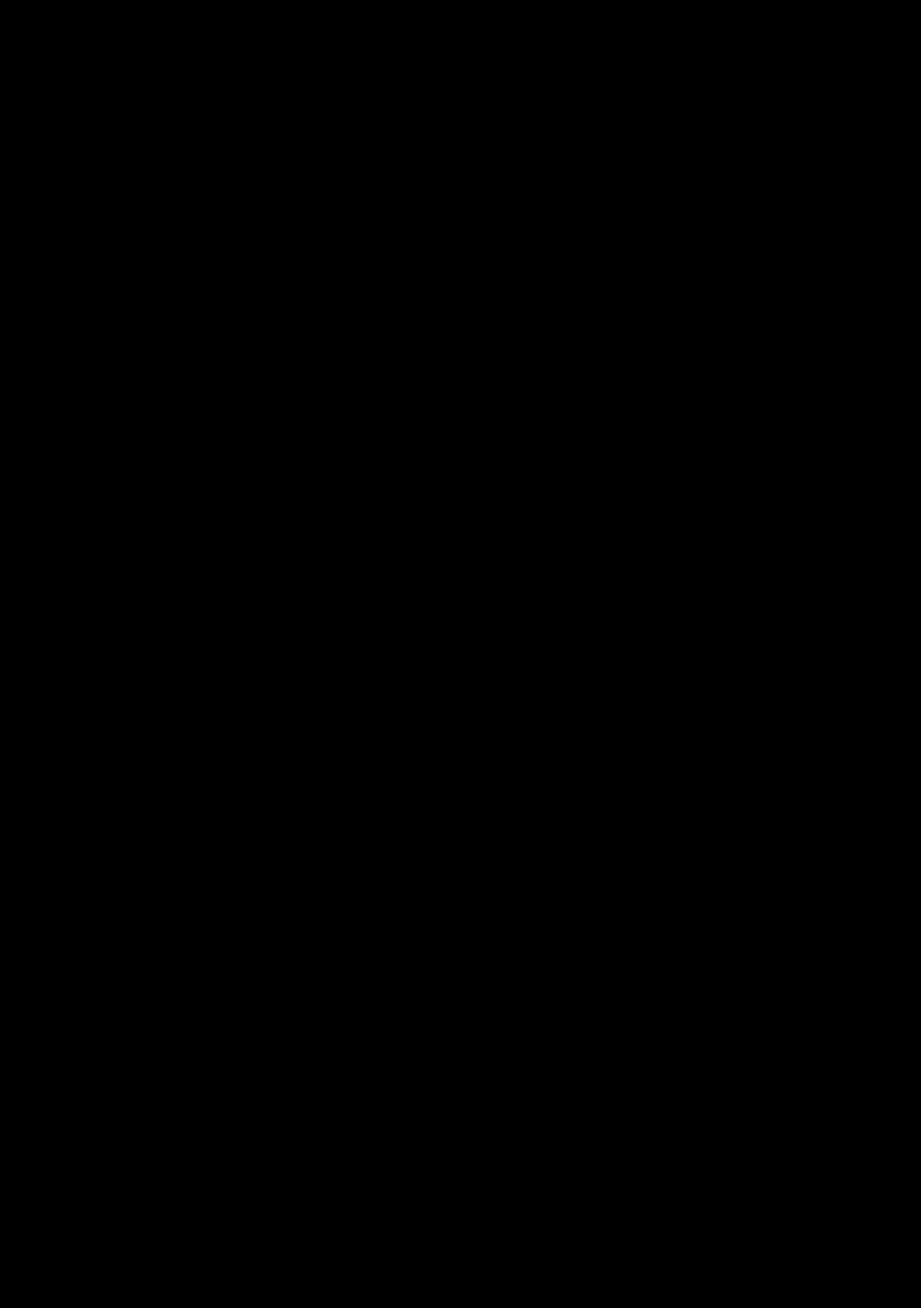

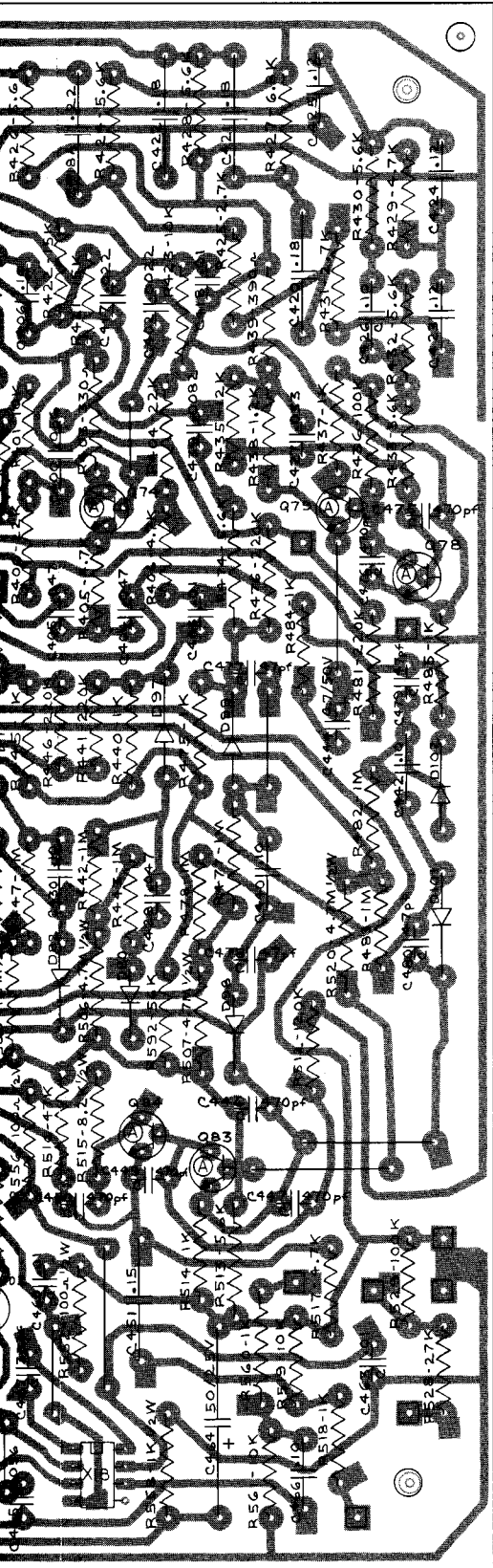

056H (127W & 128W).
 355 (127W & 128W).
 78, Q79, Q83 & Q84 PER S429-A.
 BE MATCHED FOR BASE EMITTER DROP PER S627.
 OTHERWISE SPECIFIED, CAPACITORS MARKED 'C'
 ELECTROLYTIC. UNMARKED CAPACITORS ARE

89	X	S3134-000006	SOLDER-IRON		
88	X	S3184-002003	SOLDER-DIP		
87	X	S3137-000022	WIRE BARE COPPER #22 (20 JUMPERS)		
86	4	A0516-102698	WIRE .045 SQUARE		
85	4	A0516-019255	EYELET 1/8X.089		
84					
83					
82	1	S3211-025050	CAPACITOR ELECT	50 μ f @ 25V	
81	1	S3257-350479		4.7 μ f @ 50V	
80	2	-163229		2.2 μ f @ 63V	
79	2	-163109		1 μ f @ 63V	
78	2	S3257-163688	ELECT	.68 μ f @ 63V	
77	1	S3232-001334	MYLAR	.33 μ f	
76	1	-001274		.27 μ f	
75	5	-001224		.22 μ f	
74	3	-001184		.18 μ f	
73	1	-001154		.15 μ f	
72	4	-001124		.12 μ f	
71	9	-001104		.10 μ f	
70	1	-001683		.068 μ f	
69	2	S3232-001563		.056 μ f	
68	5	S3258-050473		.047 μ f	
67	2	-050393		.039 μ f	
66	1	-050333		.033 μ f	
65	1	-050273		.027 μ f	
64	4	-050223		.022 μ f	
63	1	-050183		.018 μ f	
62	4	-050103		.010 μ f	
61	3	-050822		.0082 μ f	
60	1	-050682		.0068 μ f	
59	1	-050562		.0056 μ f	
58	1	-050392		.0039 μ f	
57	2	-050222		.0022 μ f	
56	1	S3258-050182	MYLAR	.0018 μ f	
55	5	S3256-000103	CERAMIC	.01 μ f	
54	1	-000222		.0022 μ f	
53	1	-000102		.001 μ f	
52	8	-000471		470 pF	
51	4	-000470		47 pF	
50	1	S3256-000330	CAPACITOR CERAMIC	33 pF	
49					
48					
47	6	S3252-001823	RESISTOR 1/2W 1%	182 K	
46	1	S3239-000106	1/2W	10 M	
45	7	-000475		4.7 M	
44	1	-000822		8.2 K	
43	2	-000102		1 K	
42	3	S3239-000101	1/2W	100 Ω	
41	18	S3250-000105	1/4W	1 M	
40	2	-000824		820 K	
39	4	-000474		470 K	
38	1	-000394		390 K	
37	3	-000334		330 K	
36	1	-000274		270 K	
35	9	-000224		220 K	
34	3	-000154		150 K	
33	3	-000124		120 K	
32	24	-000104		100 K	
31	1	-000823		82 K	
30	1	-000683		68 K	
29	3	-000563		56 K	
28	5	-000473		4.7 K	
27	2	-000393		3.9 K	
26	1	-000333		3.3 K	
25	2	-000273		2.7 K	
24	12	-000223		2.2 K	
23	1	-000183		18 K	
22	6	-000153		15 K	
21	1	-000123		12 K	
20	19	-000103		10 K	
19	1	-000682		6.8 K	
18	8	-000562		5.6 K	
17	5	-000472		4.7 K	
16	1	-000392		3.9 K	
15	1	-000332		3.3 K	
14	2	-000272		2.7 K	
13	6	-000222		2.2 K	
12	1	-000122		1.2 K	
11	14	-000102		1 K	
10	1	-000391		390 Ω	
9	10	S3250-000331	RESISTOR 1/4W	330 Ω	
8					
7					
6	116	A0514-042791	DIODE MED VOLTAGE		
5	13	A0514-044910	TRANSISTOR PNP		
4	29	A0514-033338	TRANSISTOR NPN		
3	1	A0507-059127	CONNECTOR RIGHT ANGLE WAFER-9PIN		
2	1	A0514-053981	IC OPERATIONAL AMPLIFIER-748		
1	1	A0575-103351	BD, DEM RIGHT HAND VOICE		

ITEM	QTY	PART NO.	PART NAME
DATE	11-10-78	OWN	J.L. FOLLETTE
APP'D	1/5	OWN SCALE	127W & 128W
USED ON	121W	PART NAME	BD, ASSY RIGHT HAND VOICE
REQ. 1		FINISH	B/M505-121W-17 GR.5 IT.
PRINT DISTRIBUTION	CIN.	GR.	CON.
	FILE	FAY.	DEQ.
		EPT.	
		2BL	1BR 3BL
ALL DRAWINGS AND SPECIFICATIONS ARE AND REMAIN THE PROPERTY OF THE BALDWIN PIANO & ORGAN CO. AND MUST BE RETURNED TO US. ALL SPECIFICATIONS ARE CONFIDENTIAL AND ARE NOT TO BE DISCLOSED TO ANY PERSON OTHER THAN THOSE TO WHOM THEY ARE SENT. NO DRAWINGS, SPECIFICATIONS OR OTHER DATA BELONGING TO THE BALDWIN PIANO & ORGAN CO. WHICH MAY BE FURNISHED TO MANUFACTURERS OR OTHERS FOR ANY PURPOSE ARE TO BE REPRODUCED BY ANY ACTION OR OTHERWISE AS IN ANY MANNER, LICENSING THE HOLDER OR ANY OTHER PERSON OR CORPORATION OR CONVEYING ANY RIGHTS OR PERMISSION TO MANUFACTURE, USE OR SELL ANY PATENTED INVENTION THAT MAY IN ANY WAY BE RELATED THERETO.			
UNLESS OTHERWISE SPECIFIED TOLERANCES ARE: DECIMAL: .005 FRACTIONAL: .015 ANGLE: 1/2°			
NEXT ASSEM. BALDWIN PIANO & ORGAN CO. CINCINNATI, OHIO			SUPERSEDES D 0500-103352 A

NOTE:
FUNCTIONS
VOICE BD
FUNCTIONS
LOGIC BD

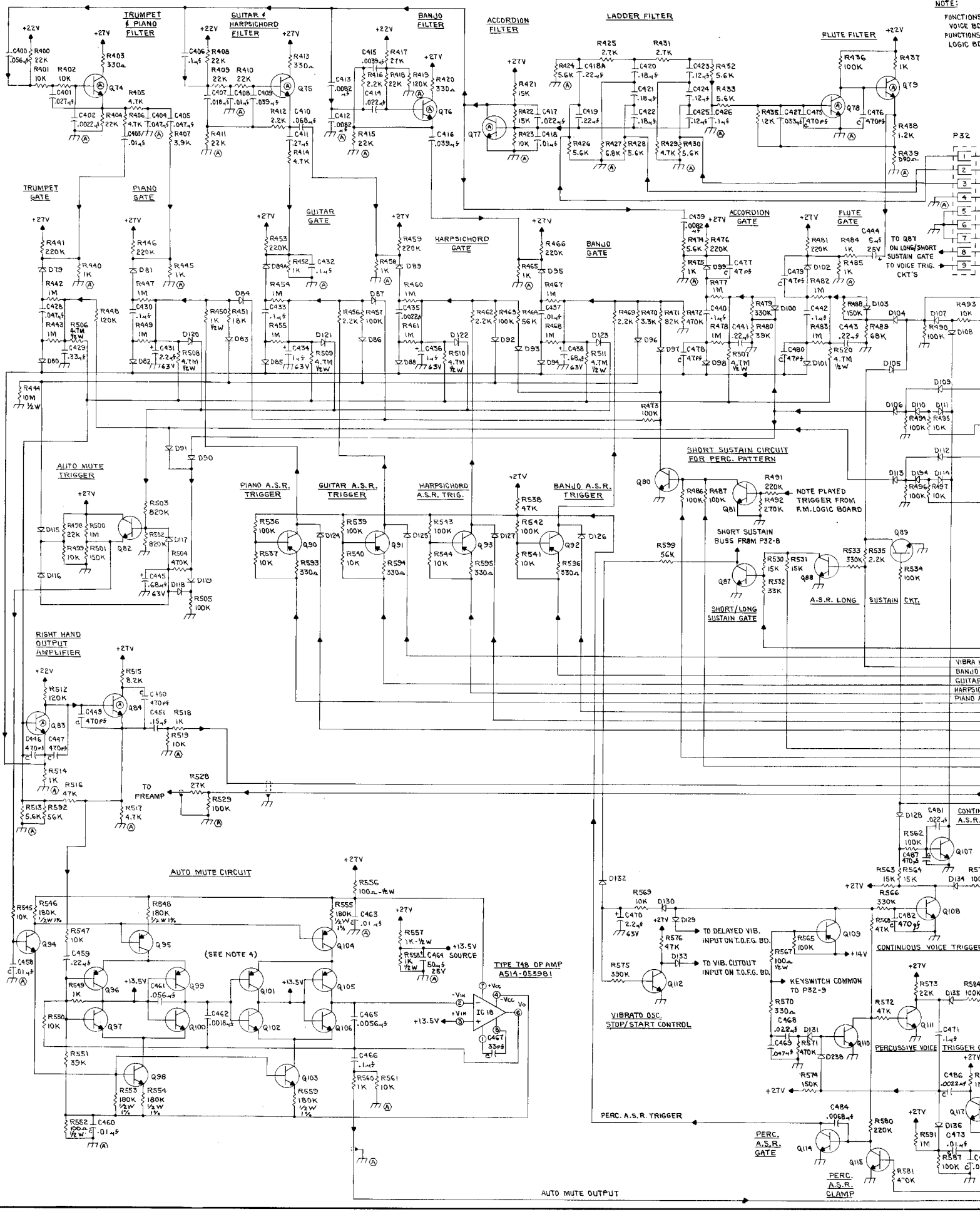

VIBRA
BANJO
GUITAR
HARPSICH
PIANO A

CONTIN
A.S.R.

KEYSWITCH COMMON
TO P32-9

PERCUSSIVE VOICE TRIGGER C

PERC. A.S.R. GATE

PERC. A.S.R. SLAMP

TYPE TAB OP AMP
AS14-0559B1

AUTO MUTE OUTPUT

P32

1
2
3
4
5
6
7
8
9

TO Q87 ON LONG/SHORT SUSTAIN GATE TO VOICE TRIG. CKT'S

NOTE:

FUNCTIONS MARKED (RHY.) CONNECT TO RHYTHM VOICE BD. REF. R501-060567. FUNCTIONS MARKED (F.M.) CONNECT TO F.M. LOGIC BD. REF. R501-060575.

ACCORDION FILTER

LADDER FILTER

FLUTE FILTER

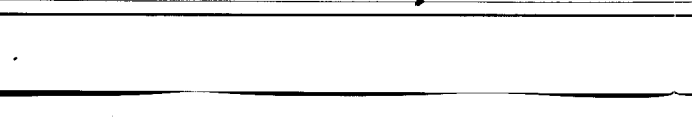
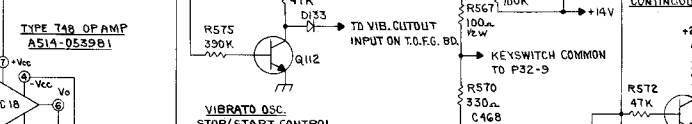
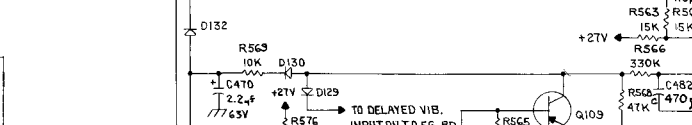
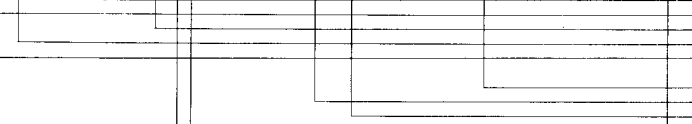
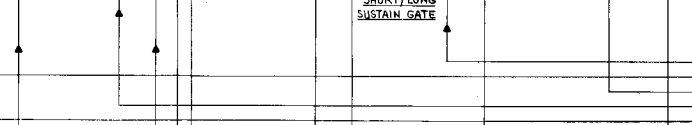
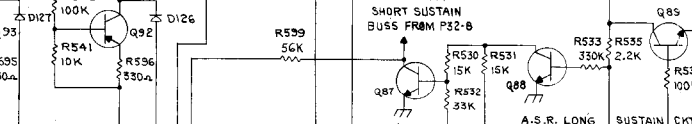
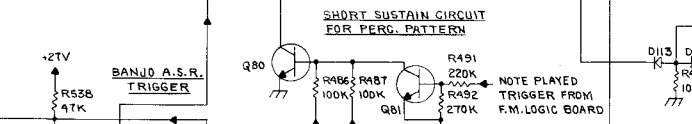
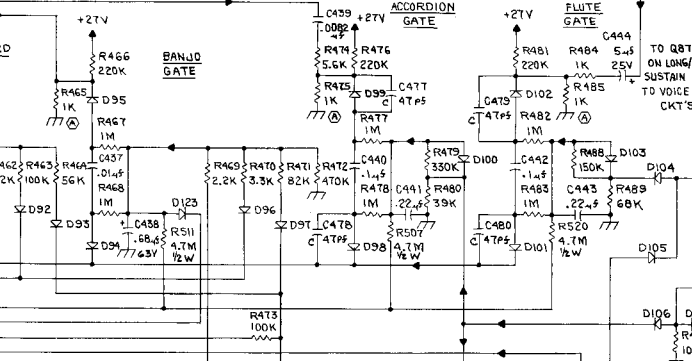
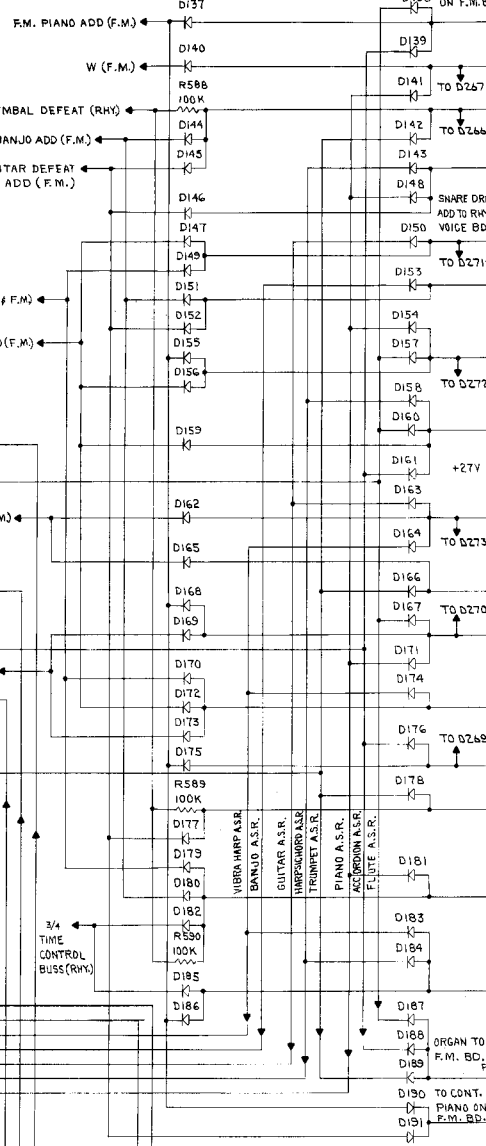
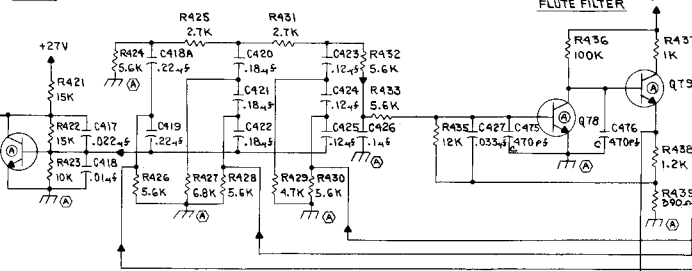

TYPE 14B OP AMP A514-0539B1

AUTO MUTE OUTPUT

STROBE OUTPUT VIA R172

OUTPUT PIN 20 OF ROM

+27V

A.S.R., RHYTHM VOICE & F.M. LOGIC PROGRAMMING

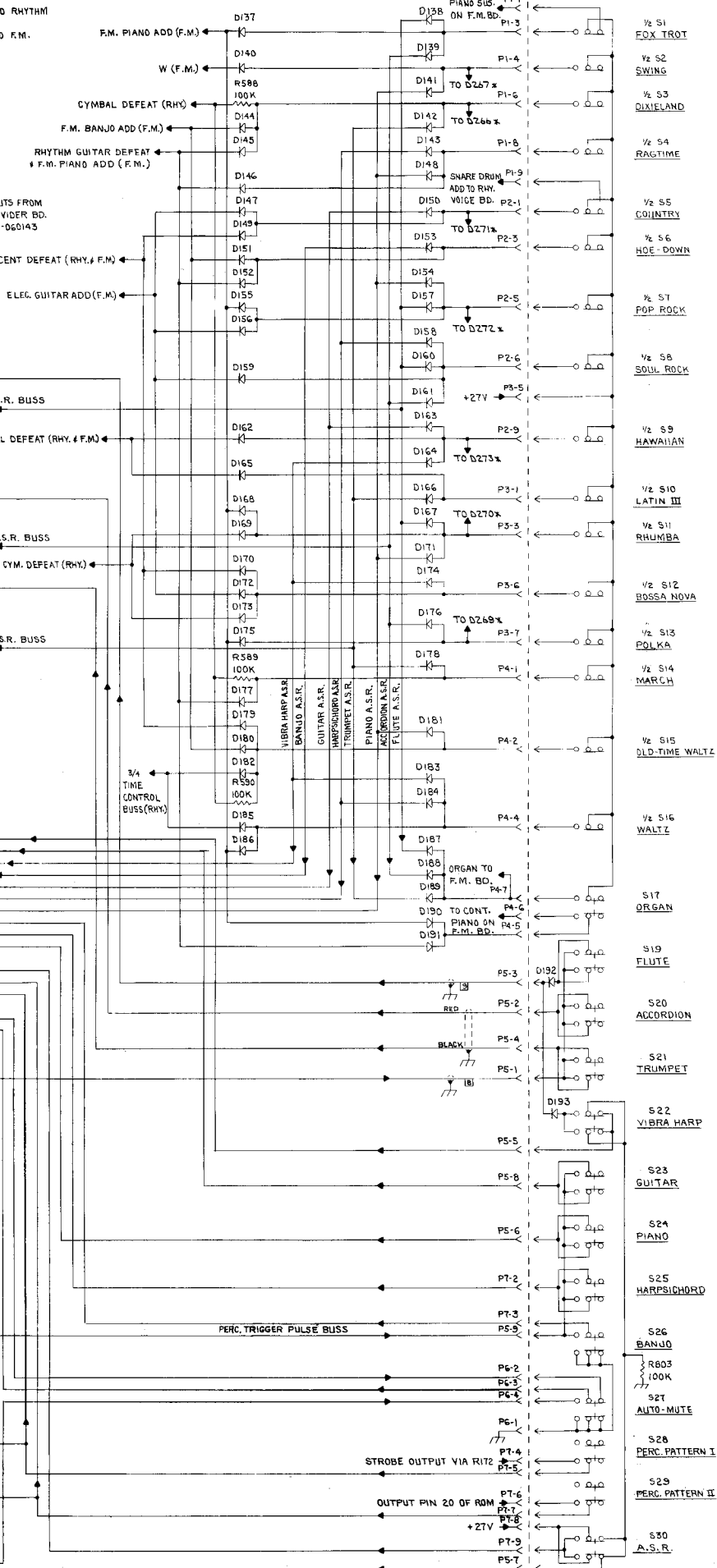

LOCATED ON CONTROL PANEL REF. D501-060267

REL. NO.	REV.	DATE	DESCRIPTION
1	1	1/31/74	INITIAL ISSUE
2	1	1/31/74	REVISIONS: R402, R443, R447, R448, R449, R450, R451, R452, R453, R454, R455, R456, R457, R458, R459, R460, R461, R462, R463, R464, R465, R466, R467, R468, R469, R470, R471, R472, R473, R474, R475, R476, R477, R478, R479, R480, R481, R482, R483, R484, R485, R486, R487, R488, R489, R490, R491, R492, R493, R494, R495, R496, R497, R498, R499, R500, R501, R502, R503, R504, R505, R506, R507, R508, R509, R510, R511, R512, R513, R514, R515, R516, R517, R518, R519, R520, R521, R522, R523, R524, R525, R526, R527, R528, R529, R530, R531, R532, R533, R534, R535, R536, R537, R538, R539, R540, R541, R542, R543, R544, R545, R546, R547, R548, R549, R550, R551, R552, R553, R554, R555, R556, R557, R558, R559, R560, R561, R562, R563, R564, R565, R566, R567, R568, R569, R570, R571, R572, R573, R574, R575, R576, R577, R578, R579, R580, R581, R582, R583, R584, R585, R586, R587, R588, R589, R590, R591, R592, R593, R594, R595, R596, R597, R598, R599, R600, R601, R602, R603, R604, R605, R606, R607, R608, R609, R610, R611, R612, R613, R614, R615, R616, R617, R618, R619, R620, R621, R622, R623, R624, R625, R626, R627, R628, R629, R630, R631, R632, R633, R634, R635, R636, R637, R638, R639, R640, R641, R642, R643, R644, R645, R646, R647, R648, R649, R650, R651, R652, R653, R654, R655, R656, R657, R658, R659, R660, R661, R662, R663, R664, R665, R666, R667, R668, R669, R670, R671, R672, R673, R674, R675, R676, R677, R678, R679, R680, R681, R682, R683, R684, R685, R686, R687, R688, R689, R690, R691, R692, R693, R694, R695, R696, R697, R698, R699, R700, R701, R702, R703, R704, R705, R706, R707, R708, R709, R710, R711, R712, R713, R714, R715, R716, R717, R718, R719, R720, R721, R722, R723, R724, R725, R726, R727, R728, R729, R730, R731, R732, R733, R734, R735, R736, R737, R738, R739, R740, R741, R742, R743, R744, R745, R746, R747, R748, R749, R750, R751, R752, R753, R754, R755, R756, R757, R758, R759, R760, R761, R762, R763, R764, R765, R766, R767, R768, R769, R770, R771, R772, R773, R774, R775, R776, R777, R778, R779, R780, R781, R782, R783, R784, R785, R786, R787, R788, R789, R790, R791, R792, R793, R794, R795, R796, R797, R798, R799, R800, R801, R802, R803, R804, R805, R806, R807, R808, R809, R810, R811, R812, R813, R814, R815, R816, R817, R818, R819, R820, R821, R822, R823, R824, R825, R826, R827, R828, R829, R830, R831, R832, R833, R834, R835, R836, R837, R838, R839, R840, R841, R842, R843, R844, R845, R846, R847, R848, R849, R850, R851, R852, R853, R854, R855, R856, R857, R858, R859, R860, R861, R862, R863, R864, R865, R866, R867, R868, R869, R870, R871, R872, R873, R874, R875, R876, R877, R878, R879, R880, R881, R882, R883, R884, R885, R886, R887, R888, R889, R890, R891, R892, R893, R894, R895, R896, R897, R898, R899, R900, R901, R902, R903, R904, R905, R906, R907, R908, R909, R910, R911, R912, R913, R914, R915, R916, R917, R918, R919, R920, R921, R922, R923, R924, R925, R926, R927, R928, R929, R930, R931, R932, R933, R934, R935, R936, R937, R938, R939, R940, R941, R942, R943, R944, R945, R946, R947, R948, R949, R950, R951, R952, R953, R954, R955, R956, R957, R958, R959, R960, R961, R962, R963, R964, R965, R966, R967, R968, R969, R970, R971, R972, R973, R974, R975, R976, R977, R978, R979, R980, R981, R982, R983, R984, R985, R986, R987, R988, R989, R990, R991, R992, R993, R994, R995, R996, R997, R998, R999, R1000.

- NOTES:
- ALL RESISTORS ARE 1/4W 5% UNLESS OTHERWISE SPECIFIED.
 - SELECT NPN TRANSISTORS PER 5429 - AS INDICATED.
 - D.C. VOLTAGE MEASUREMENTS TAKEN WITH A VOLTMETER (20,000 OHM PER VOLT OR HIGHER) FROM POINT INDICATED TO GROUND.
 - Q96, Q99, Q100, Q101, Q105, Q102, Q106 MUST BE MATCHED FOR BASE-EMITTER DROP PER 5427.
 - TWO GROUND SYSTEMS DESIGNATED AS FOLLOWS:
 # - PREAMP GROUND FOR SWITCHING CIRCUITS.
 # - PREAMP GROUND FOR SIGNAL CIRCUITS.
 - X - REFERS TO COMPONENTS LOCATED ON THE F.M. LOGIC BS. 121W ONLY

REL. NO.	REV.	DATE	DESCRIPTION
1	1	1/31/74	INITIAL ISSUE
2	1	1/31/74	REVISIONS: R402, R443, R447, R448, R449, R450, R451, R452, R453, R454, R455, R456, R457, R458, R459, R460, R461, R462, R463, R464, R465, R466, R467, R468, R469, R470, R471, R472, R473, R474, R475, R476, R477, R478, R479, R480, R481, R482, R483, R484, R485, R486, R487, R488, R489, R490, R491, R492, R493, R494, R495, R496, R497, R498, R499, R500, R501, R502, R503, R504, R505, R506, R507, R508, R509, R510, R511, R512, R513, R514, R515, R516, R517, R518, R519, R520, R521, R522, R523, R524, R525, R526, R527, R528, R529, R530, R531, R532, R533, R534, R535, R536, R537, R538, R539, R540, R541, R542, R543, R544, R545, R546, R547, R548, R549, R550, R551, R552, R553, R554, R555, R556, R557, R558, R559, R560, R561, R562, R563, R564, R565, R566, R567, R568, R569, R570, R571, R572, R573, R574, R575, R576, R577, R578, R579, R580, R581, R582, R583, R584, R585, R586, R587, R588, R589, R590, R591, R592, R593, R594, R595, R596, R597, R598, R599, R600, R601, R602, R603, R604, R605, R606, R607, R608, R609, R610, R611, R612, R613, R614, R615, R616, R617, R618, R619, R620, R621, R622, R623, R624, R625, R626, R627, R628, R629, R630, R631, R632, R633, R634, R635, R636, R637, R638, R639, R640, R641, R642, R643, R644, R645, R646, R647, R648, R649, R650, R651, R652, R653, R654, R655, R656, R657, R658, R659, R660, R661, R662, R663, R664, R665, R666, R667, R668, R669, R670, R671, R672, R673, R674, R675, R676, R677, R678, R679, R680, R681, R682, R683, R684, R685, R686, R687, R688, R689, R690, R691, R692, R693, R694, R695, R696, R697, R698, R699, R700, R701, R702, R703, R704, R705, R706, R707, R708, R709, R710, R711, R712, R713, R714, R715, R716, R717, R718, R719, R720, R721, R722, R723, R724, R725, R726, R727, R728, R729, R730, R731, R732, R733, R734, R735, R736, R737, R738, R739, R740, R741, R742, R743, R744, R745, R746, R747, R748, R749, R750, R751, R752, R753, R754, R755, R756, R757, R758, R759, R760, R761, R762, R763, R764, R765, R766, R767, R768, R769, R770, R771, R772, R773, R774, R775, R776, R777, R778, R779, R780, R781, R782, R783, R784, R785, R786, R787, R788, R789, R790, R791, R792, R793, R794, R795, R796, R797, R798, R799, R800, R801, R802, R803, R804, R805, R806, R807, R808, R809, R810, R811, R812, R813, R814, R815, R816, R817, R818, R819, R820, R821, R822, R823, R824, R825, R826, R827, R828, R829, R830, R831, R832, R833, R834, R835, R836, R837, R838, R839, R840, R841, R842, R843, R844, R845, R846, R847, R848, R849, R850, R851, R852, R853, R854, R855, R856, R857, R858, R859, R860, R861, R862, R863, R864, R865, R866, R867, R868, R869, R870, R871, R872, R873, R874, R875, R876, R877, R878, R879, R880, R881, R882, R883, R884, R885, R886, R887, R888, R889, R890, R891, R892, R893, R894, R895, R896, R897, R898, R899, R900, R901, R902, R903, R904, R905, R906, R907, R908, R909, R910, R911, R912, R913, R914, R915, R916, R917, R918, R919, R920, R921, R922, R923, R924, R925, R926, R927, R928, R929, R930, R931, R932, R933, R934, R935, R936, R937, R938, R939, R940, R941, R942, R943, R944, R945, R946, R947, R948, R949, R950, R951, R952, R953, R954, R955, R956, R957, R958, R959, R960, R961, R962, R963, R964, R965, R966, R967, R968, R969, R970, R971, R972, R973, R974, R975, R976, R977, R978, R979, R980, R981, R982, R983, R984, R985, R986, R987, R988, R989, R990, R991, R992, R993, R994, R995, R996, R997, R998, R999, R1000.

DATE: 5-5-74
 DRAWN: D.DIEHL
 CHECKED: [Signature]
 APPROVED: [Signature]
 PART NAME: RIGHT HAND VOICE BD. SCHEMATIC
 PART NO.: 503-121W-17
 BALDWIN PIANO & ORGAN CO. CINCINNATI, OHIO
 R 0501-060699 J

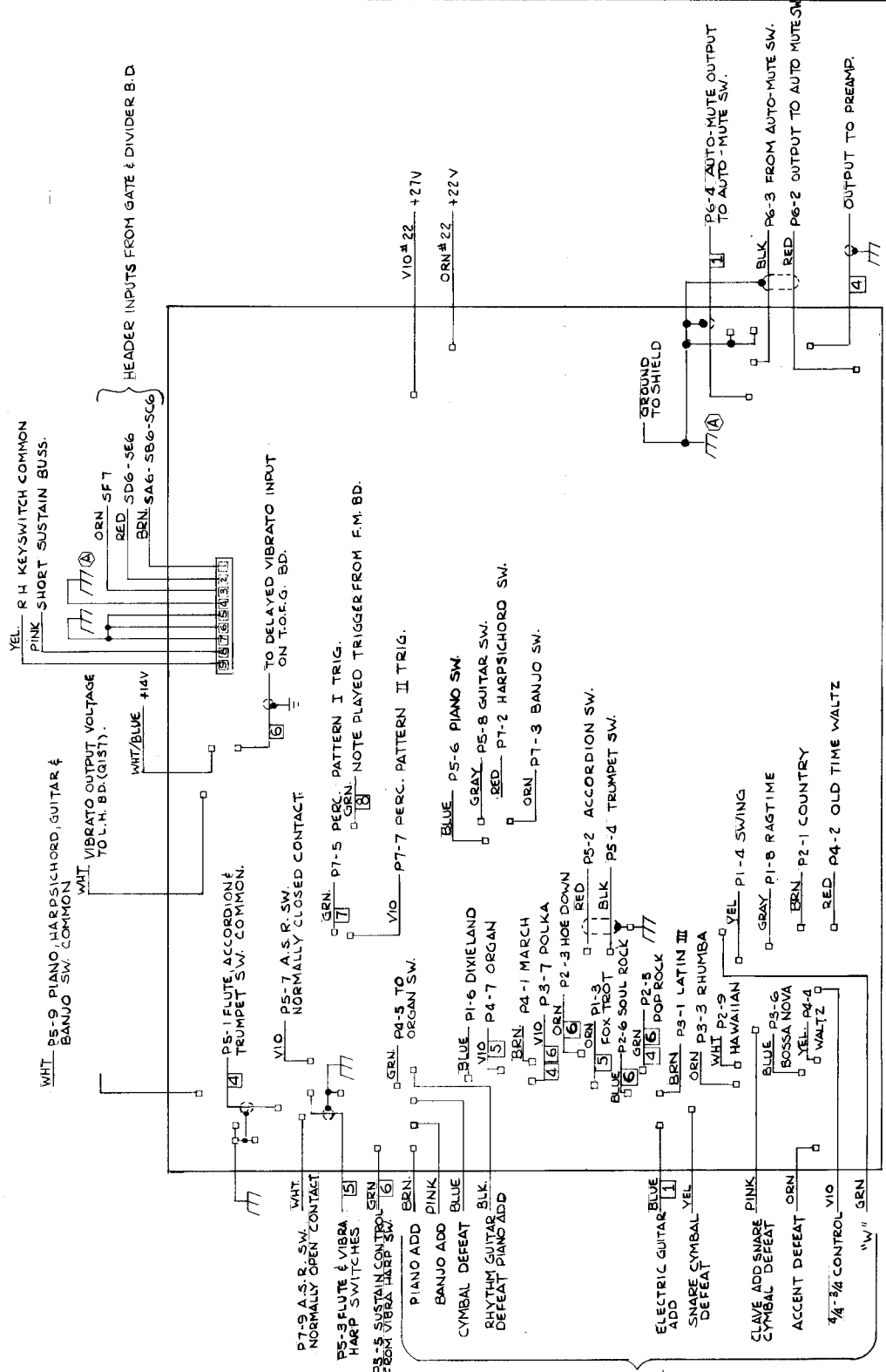

DATE 11-21-78	OWN. D. MOSSMAN	GRD.	APPRD. JAS	DOWN SCALE FULL	USED ON 121W	PART NAME
PRINT	CIN	GR.	CON.	FAY.	DEO.	E.P.T.
DESCRIPTION	S			2 BL-188	3 BL	
ALL DIMENSIONS AND SPECIFICATIONS ARE AND REMAIN THE PROPERTY OF THE BALDWIN PIANO & ORGAN CO. AND WILL BE TO WHOM THE INSTRUMENT IS SOLD. TO UNLESS OTHERWISE SPECIFIED, DIMENSIONS TO THE BALDWIN PIANO & ORGAN CO. DRAWINGS ARE TO BE USED. THE BALDWIN PIANO & ORGAN CO. IS NOT RESPONSIBLE FOR THE ACCURACY OF THE DIMENSIONS OF THE INSTRUMENTS MANUFACTURED BY OTHER MANUFACTURERS. THE BALDWIN PIANO & ORGAN CO. IS NOT RESPONSIBLE FOR THE ACCURACY OF THE DIMENSIONS OF THE INSTRUMENTS MANUFACTURED BY OTHER MANUFACTURERS. THE BALDWIN PIANO & ORGAN CO. IS NOT RESPONSIBLE FOR THE ACCURACY OF THE DIMENSIONS OF THE INSTRUMENTS MANUFACTURED BY OTHER MANUFACTURERS.						
UNLESS OTHERWISE SPECIFIED TOLERANCES ARE DECIMAL: .000 FRACTIONAL: 2/101 ANGLE: 1/4"						
FINISH					REQ. SEE B/M	BIM 508-121W-17 OR NOTED IT.
NEXT ASSEMB.					SUPERSEDES	
BALDWIN PIANO & ORGAN CO.					C 0501-103354	
CINCINNATI, OHIO					BDC	

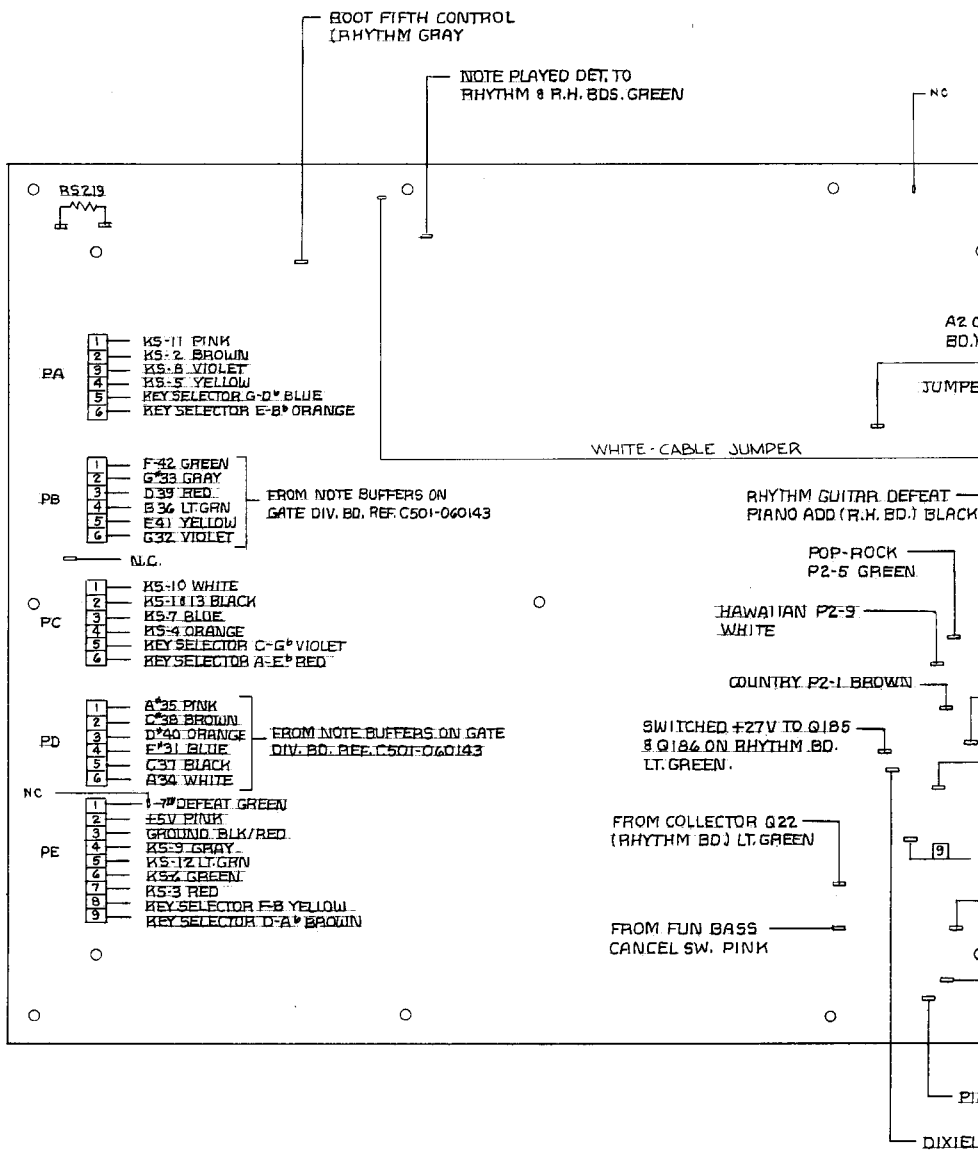

RECORD OF CHANGE
 A) ADDED WHITE CBL JUMPER.
 C.N.17,378 7-12-77 DRP

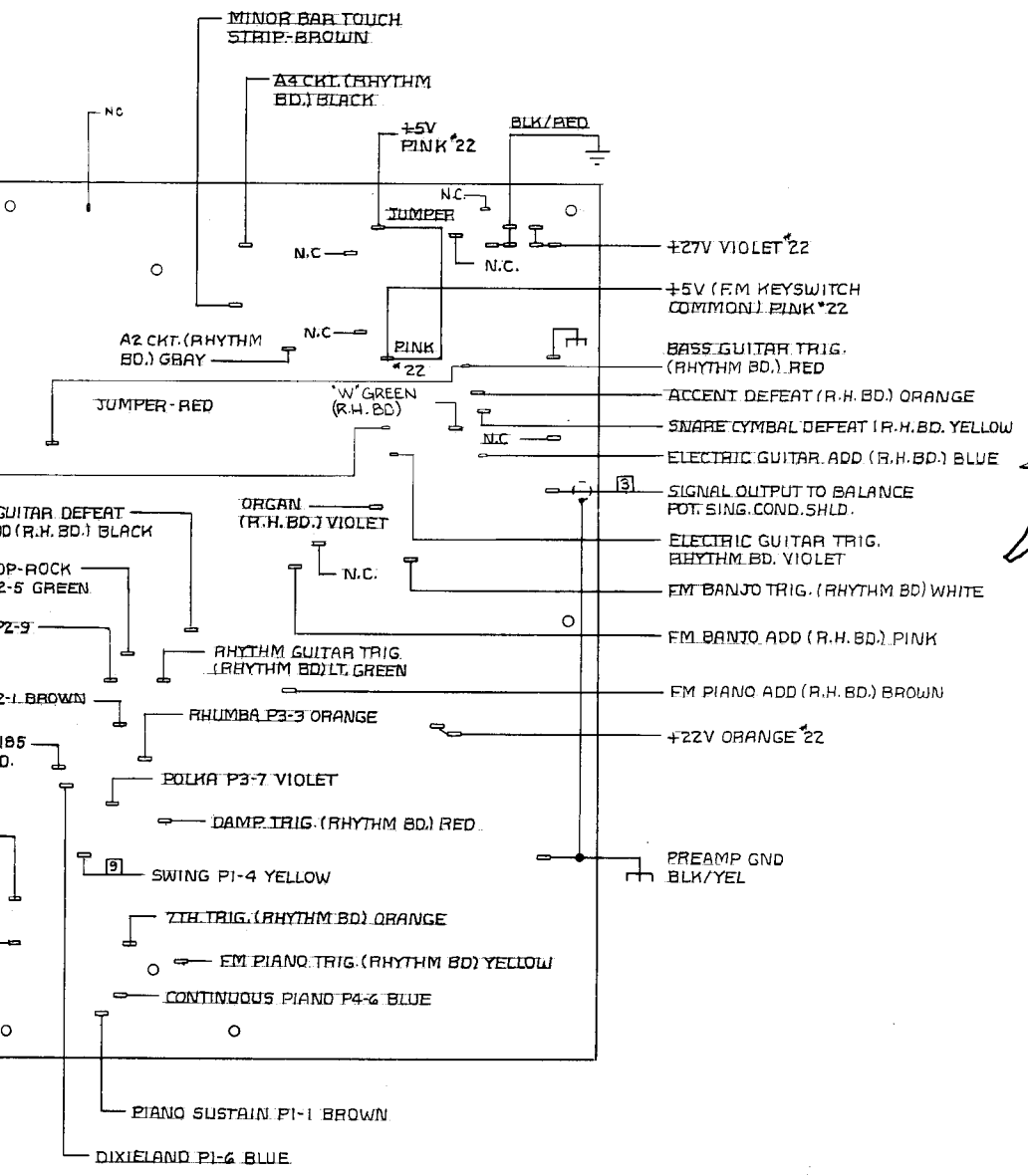

REF: F.M. LOGIC BD. SCHEM. R3501-100770.

DATE: 10-5-76	OWN: D. PEALE	CH'D.	APP'D. [Signature]	DWN. SCALE	USED ON 121W	PART NAME	
PRINT DISTRIBUTION	CIN. 5	GR.	CON.	FAY. 48L 1BR	DEG. 3BL.	E.P.T.	BD. F.M. LOGIC PIN WIRING DIAGRAM
FINISH						REQ.	B/M503-121W-17 GR. NOTE IT.
NEXT ASSEM.						SUPERSEDES	
UNLESS OTHERWISE SPECIFIED TOLERANCES ARE: DECIMAL ±.005 FRACTIONAL ±.015 ANGLE ±1/2°						BALDWIN PIANO & ORGAN CO. CINCINNATI, OHIO	D 0501-100945 A

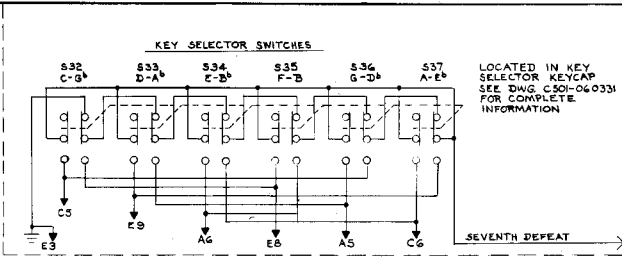

- NOTES:**
1. DC VOLTAGE MEASUREMENTS TAKEN WITH A VOLTMETER (20,000 Ω PER VOLT OR HIGHER) FROM POINT INDICATED TO GROUND.
 2. ALL RESISTORS ARE 1/4 W 5% UNLESS OTHERWISE SPECIFIED.
 3. SELECT NPN TRANSISTORS PER S-423-AS INDICATED.
 4. SELECT R219 PER STOB. SELECTION RANGE 220 Ω TO 10K.
 5. IC3 THRU 14: #21: AS14-060021 HEX INVERTER TYPE 7405.
 6. IC20 IS TRANSISTOR ARRAY 2 NPN AS14-063527.
 7. IC22: AS14-058464, QUAD 2 INPUT NAND TYPE 7403.
 8. IC17: AS14-054489, DUAL JK FLIP FLOP TYPE 74107.
 9. IC23: AS14-058465, 2 INPUT NOR GATE TYPE 7402.
 10. IC24: AS14-058463, 2 INPUT NAND GATE TYPE 7400.
 11. IC25 #26: AS14-063582, 3 INPUT NAND GATE TYPE 7412.
 12. TWO GROUND SYSTEMS DESIGNATED AS:
 - ⊕ GENERAL GROUND FOR SWITCHING CIRCUITS.
 - ⊖ PREAMP GROUND FOR SIGNAL CIRCUITS.

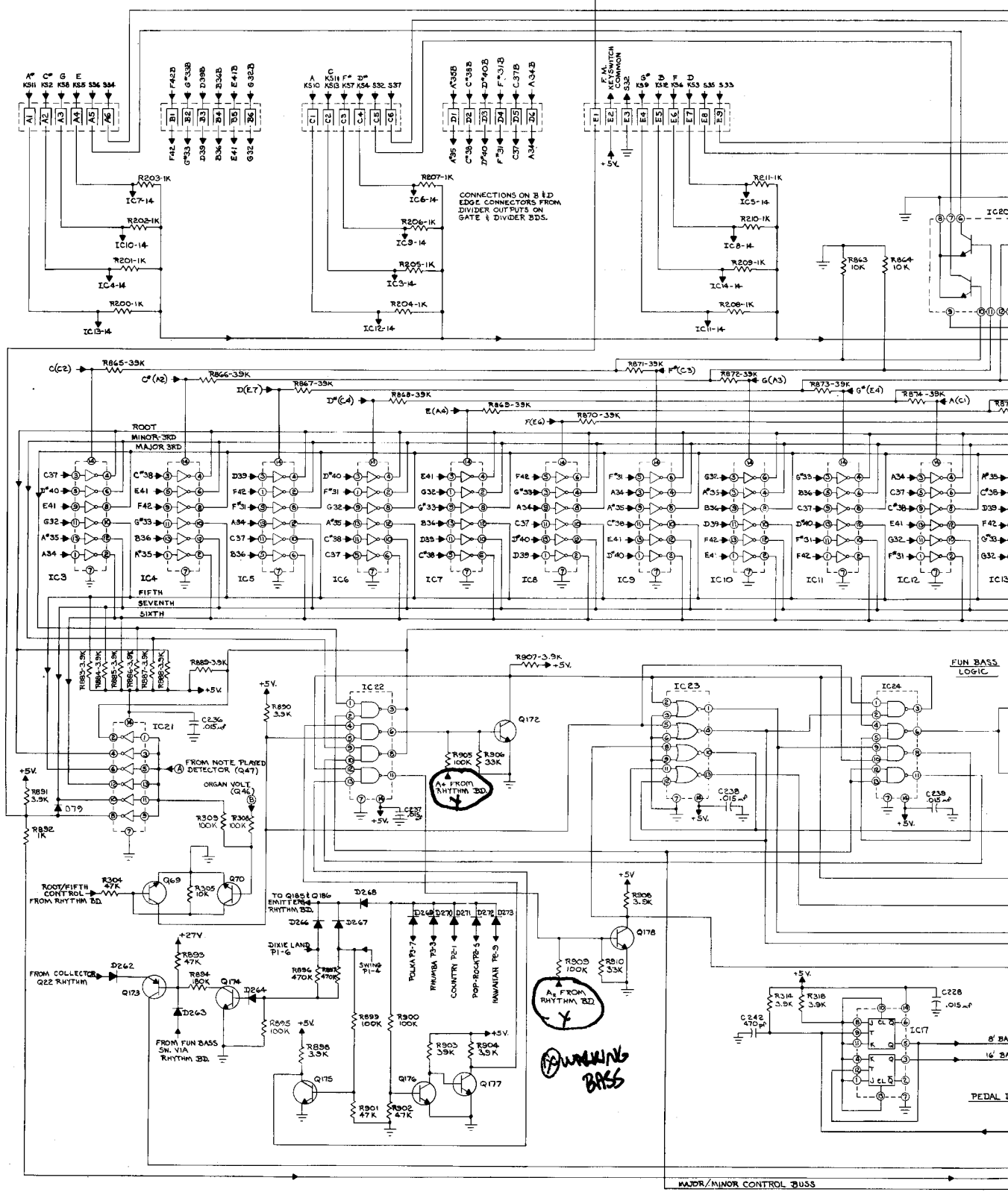

METER
 LATED TO GROUND.
 SPECIFIED.
 ED.
 TO 10K.
 TYPE 7405.

7403.
 74107.
 7402.
 7400.
 7412.

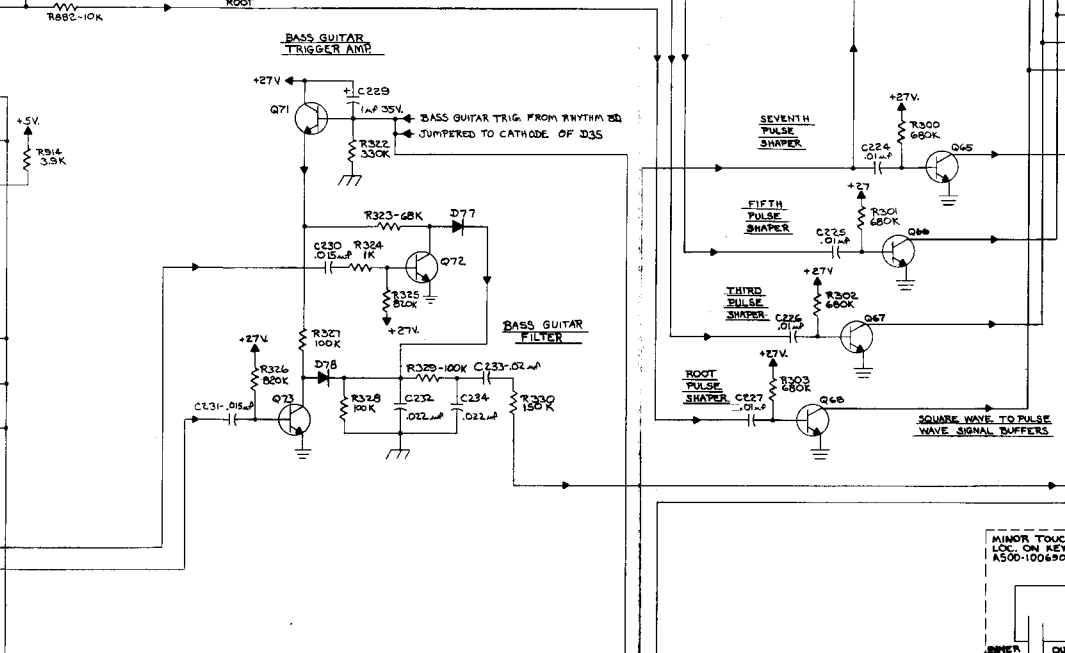
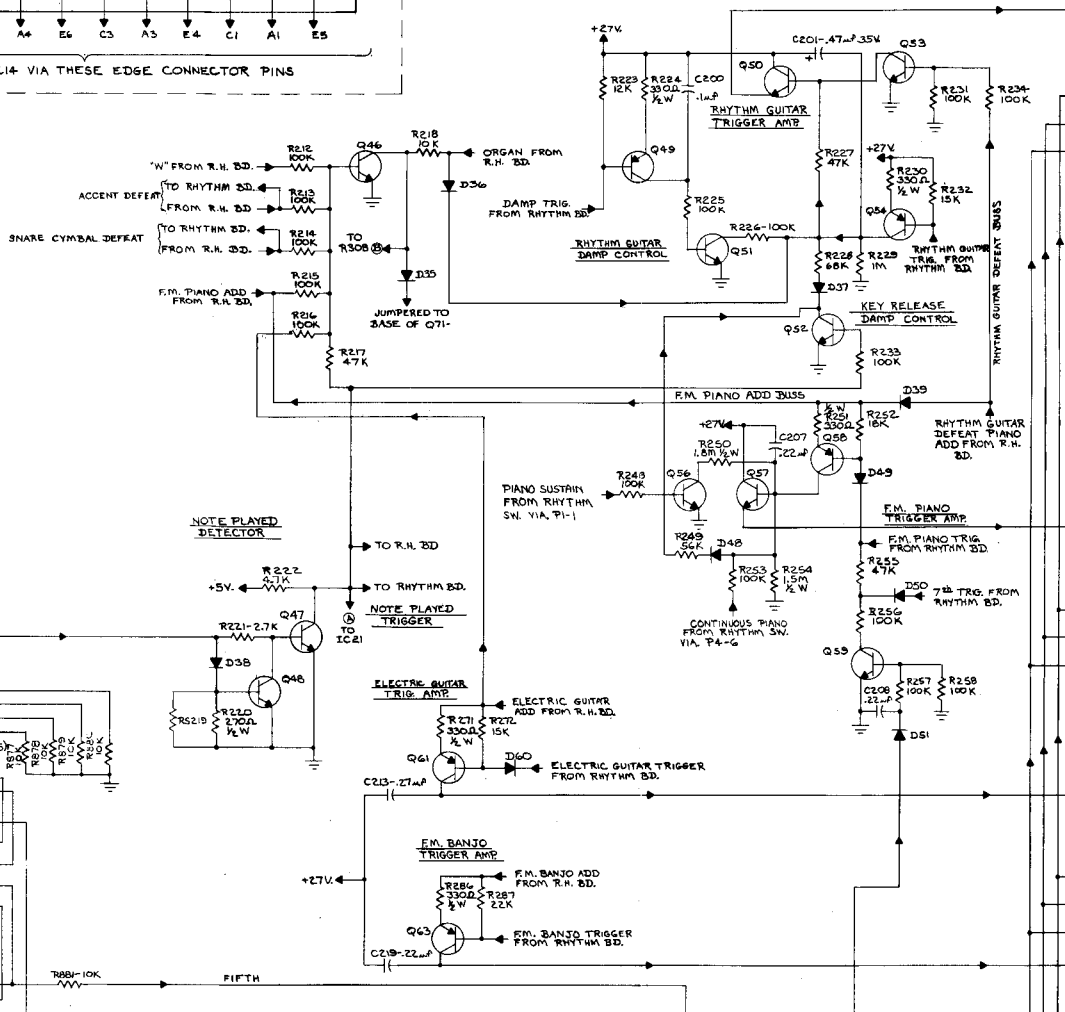
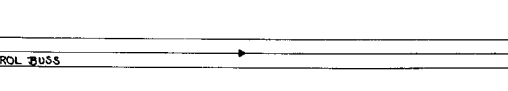
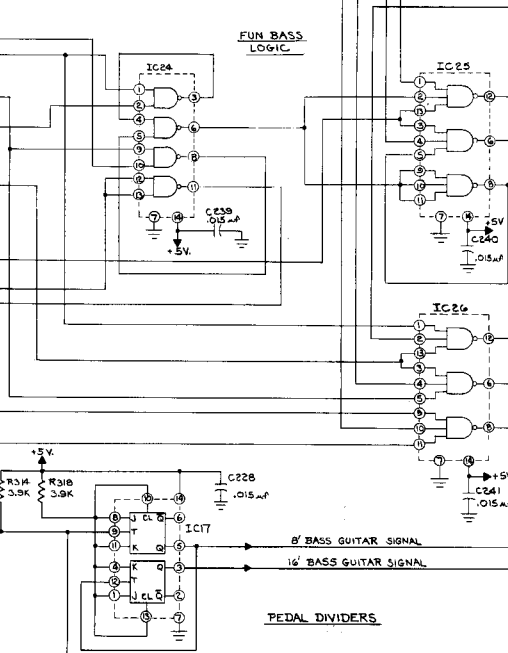
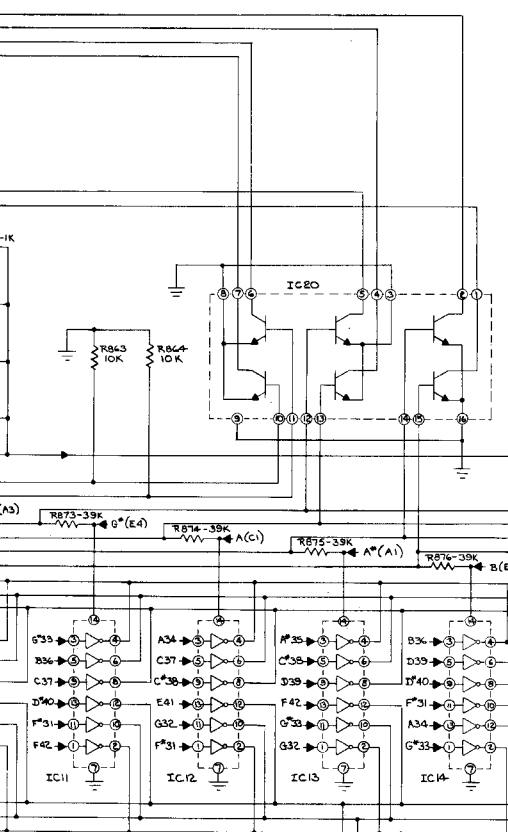
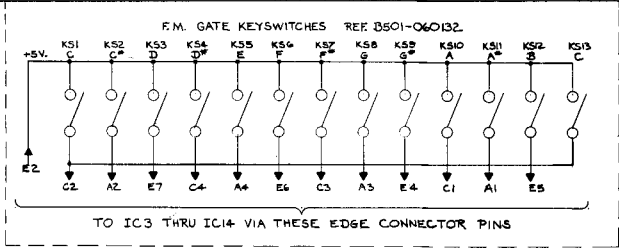

RELEASED
 Ord. No. CN16972
 Date 11/2/96

RECORD OF CHANGE

Q GND ON Q71 WAS 77
 C.N. 11514 2-17-77 DRB

Q REVISED MINOR
 TOUCH STRIP CKT ADDED
 R200, R201, C244 & D277
 C208 WAS 201
 C.N. 11528 5-27-77 DRB

Q CONNECTED R217
 WITH Q. R222 WAS 10K
 R208 & R209 WERE
 25K. DELETED D705.
 ADDED D709.
 CONNECTED PIN 9 & 11
 OF IC 21.
 C.N. 11578 6-23-77 DRB

D R217 WAS 4.7K
 R222 WAS 470K
 C.N. 11528 2-18-78

E TOUCH STRIP CKT.
 ADDED R232 & D278
 C.N. 16152 DP 10-31-78

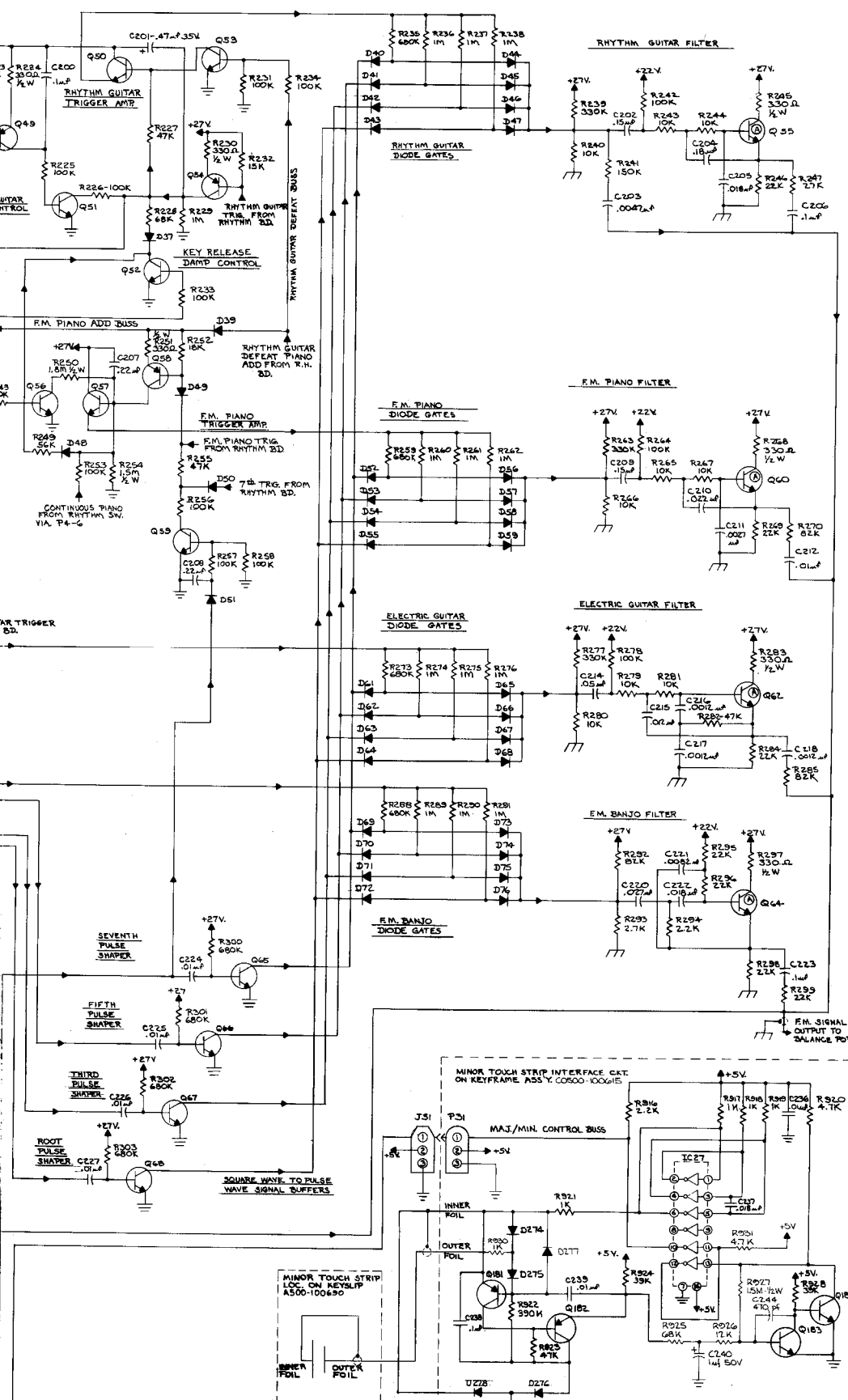

COMPONENT NOS	QTY	VAL	REF	TEST	DATE	BY
R200-R201	2	100K				
C200-C204	5	100K				
D24-D27	4	1N4148				
D28-D31	4	1N4148				
D32-D35	4	1N4148				
D36-D39	4	1N4148				
D40-D47	8	1N4148				
D48-D55	8	1N4148				
D60-D68	9	1N4148				
D69-D72	4	1N4148				
Q50-Q55	6	2N3055				
Q62-Q68	7	2N3055				
U278	1	74138				

SCHEMATIC F.M. LOGIC BD

DATE: 11/2/96

BY: [Signature]

REVISION: 1

0501-100779 E

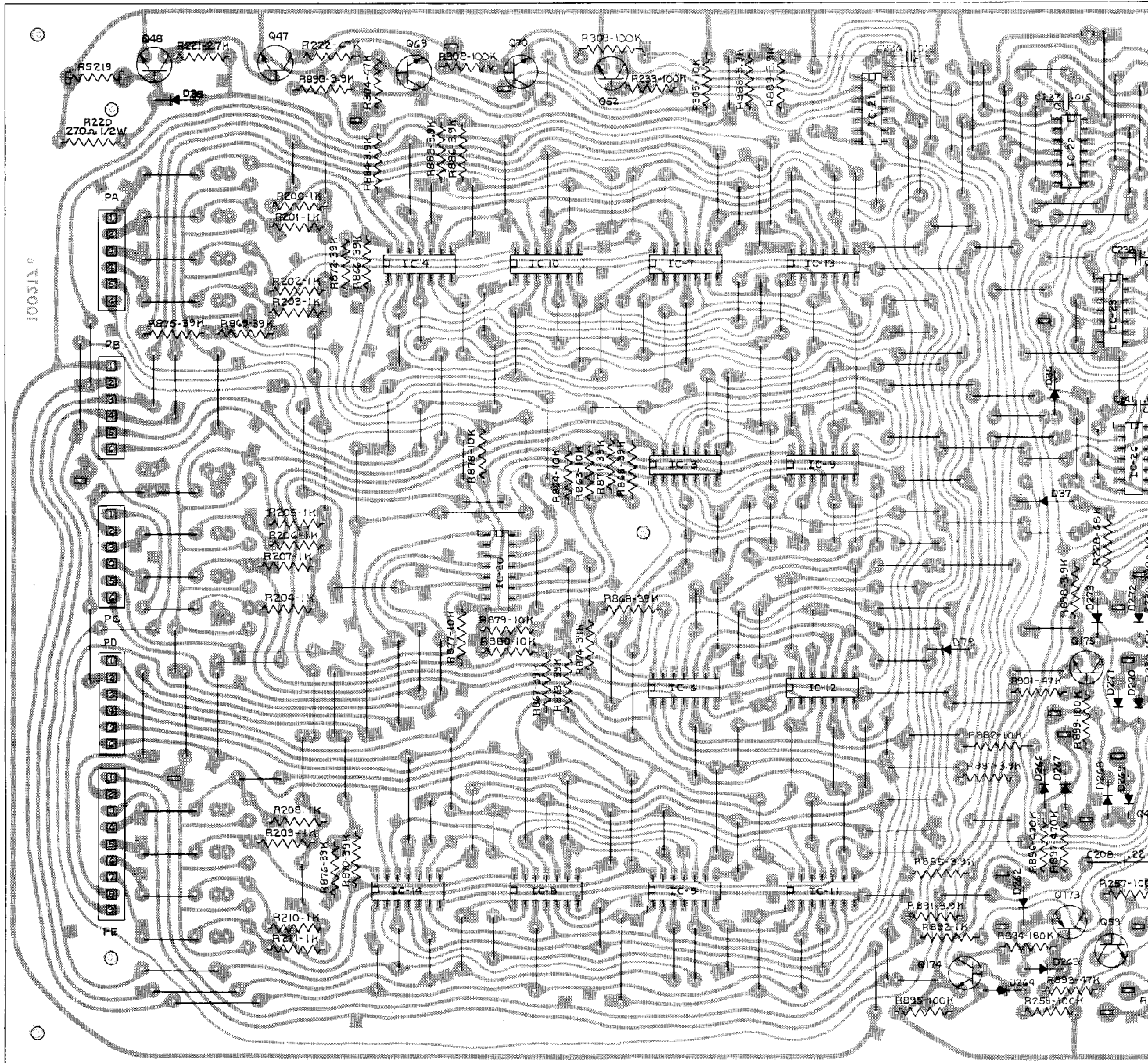

NOTES

1. REFERENCE SCHEMATIC R501-100779 - WIR. DIAG. LOC 31-1009-45
2. ALL RESISTORS ARE 1/4W 5% UNLESS OTHERWISE SPECIFIED.
3. ALL CAPACITORS ARE IN MICROFARAD UNLESS OTHERWISE SPECIFIED. CAPACITORS MARKED 'C' ARE CERAMIC
4. I.C. 3 THRU 14 & 21: A514-060021
 I.C. 20: A514-063227
 I.C. 22: A514-059464
 I.C. 17: A514-054499
 I.C. 23: A514-058465
 I.C. 24: A514-059463
 I.C. 25 & 26: A514-063392
5. SELECTED TRANSISTORS ARE Q55, Q60, Q62 & Q64
6. SELECT R219 PER 5709, SELECTION RANGE 220Ω TO 10K.
7. FINAL ASSY MUST INCLUDE PART NO. R0500-132979A.

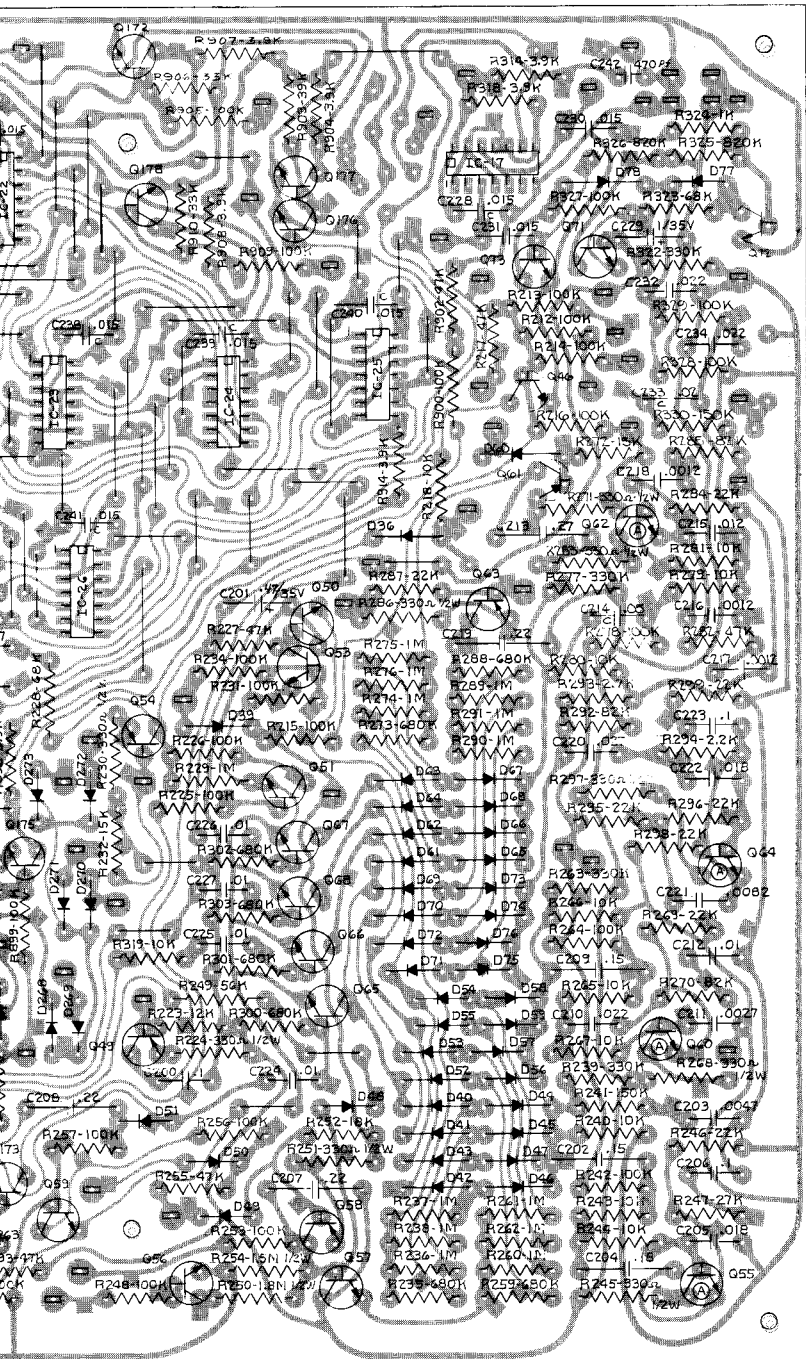

70	X	53194-6	SOLDER-IRON
69	X	5184-3	SOLDER-DIP
68	X	5137-4	WIRE #22 BARE CU
67			
66	I	5744-35-105-2	CAPACITOR TANT 35V 20% .1uf
65	I	5244-35-474-1	II II 35V 10% .47uf
64	T	5205-153	CAPACITOR CERAMIC .015uf
63	I	5218-502	II II .05 uf
62	I	5205-209	II II .02 uf
61	I	5205-471	II II 470 pF
60			
59	I	5232-01-274	CAPACITOR NYLAR .27uf
58	3	5232-01-224	II II .22uf
57	I	5232-01-184	II II .18uf
56	2	5232-01-154	II II .15uf
55	3	5232-01-104	II II .1uf
54	I	5232-01-273	II II .027uf
53	3	5232-01-223	II II .022uf
52	2	5232-01-183	II II .018uf
51	I	5232-01-123	II II .012uf
50	5	5232-01-103	II II .01uf
49	I	5232-01-822	II II .0082uf
48	I	5232-01-472	II II .0047uf
47	I	5232-01-272	II II .0027uf
46	3	5232-01-122	II II .0012uf
45	2	5232-01-153	II II .015uf
44	I	5239-185	RESISTOR 1/2W 10% 1.8M
43	I	5239-155	II II 1.5M
42	3	5239-331	II II 330Ω
41	I	5239-271	II II 270Ω
40	T	53750-00047Z	RESISTOR 1/4W 5% 4.7K
39	I	5250-XXX	RESISTOR 1/4W 5% SELECT
38	13	5250-105	II II 105
37	2	5250-824	II II 820K
36	8	5250-684	II II 680K
35	2	5250-474	II II 470K
34	4	5250-334	II II 330K
33	I	5250-184	II II 180K
32	2	5250-154	II II 150K
31	30	5250-104	II II 100K
30	3	5250-823	II II 82K
29	2	5250-683	II II 68K
28	I	5250-563	II II 56K
27	B	5250-473	II II 47K
26	13	5250-333	II II 33K
25	2	5250-333	II II 33K
24	I	5250-273	II II 27K
23	8	5250-223	II II 22K
22	I	5250-183	II II 18K
21	2	5250-153	II II 15K
20	I	5250-123	II II 12K
19	19	5250-103	II II 10K
18	I	5250-682	II II 6.8K
17	16	5250-392	II II 3.9K
16	2	5250-272	II II 2.7K
15	I	5250-222	II II 2.2K
14	14	5250-102	II II 1K
13	I	A507-059127	CONNECTION WAFER AT ANGLE 9
12	4	A507-059125	CONNECTION WAFER AT ANGLE 6
11	2	A514-063982	I.C. 3 INPUT NAND GATE
10	I	A514-059463	I.C. 2 INPUT NAND GATE
9	I	A514-053465	I.C. 2 INPUT NOR GATE
8	I	A514-054489	I.C. DUAL JK FLIP FLOP
7	I	A514-059464	I.C. GUARD 2 INPUT NAND GATE
6	I	A514-063227	I.C. TRANSISTOR ARRAY 6PNP
5	13	A514-060021	I.C. HEX INVERTER
4	6	A514-044910	TRANSISTOR PNP S.M. SIGNAL
3	29	A514-03333B	TRANSISTOR NPN S.M. SIGNAL
2	58	A514-042731	DIODE MEDIUM VOLTAGE
1	I	B0505-102978	BD.E.M LOGIC-RIVETED

DATE 10-11-76
 T. FUNK
 FILE 251-10A-38L
 BALDWIN PIANO & ORGAN CO. CINCINNATI, OHIO
 ASSY F.M. LOGIC BD.
 SUPERSEDES R0500-10076C
 R 0500-102979 A

NOTES

- 1 REFERENCE SCHEMATIC R501-100779 - WIR. DIAG. 2050-100766
- 2 ALL RESISTORS 6P 1/2W 5% UNLESS OTHERWISE SPECIFIED.
- 3 ALL CAPACITORS ARE IN MICROFARAD UNLESS OTHERWISE SPECIFIED. CAPACITORS MARKED 'C' ARE CERAMIC
- 4 I.C. 3 THRU 14 9 21: A514-060021
- 5 I.C. 20: A0514-063227
- 6 I.C. 22: A0514-059464
- 7 I.C. 17: A0514-054489
- 8 I.C. 23: A0514-059465
- 9 I.C. 24: A0514-059463
- 10 I.C. 25 4 26: A0514-063882
- 11 SELECTED TRANSISTORS ARE Q55, Q60, Q62 8 Q64
- 12 SELECT R219 PER 5709, SELECTION RANGE 220Ω TO 10K
- 13 FINAL ASSY. MUST INCLUDE PART NO. R0500-100766

RELEASED
 Ord. No. CN 16,878
 Date 11/12/76

RECORD OF CHANGE

(A) RELOCATED Q72 PER A.W. CN 17124 2-17-77 DRB

(B) REVISED TO SEPARATE D60 FROM C218, ADDED D79, DELETED D265. R272 WAS 10K, R300 R309 WERE 25K. CN 17,5186-22-77 DRB

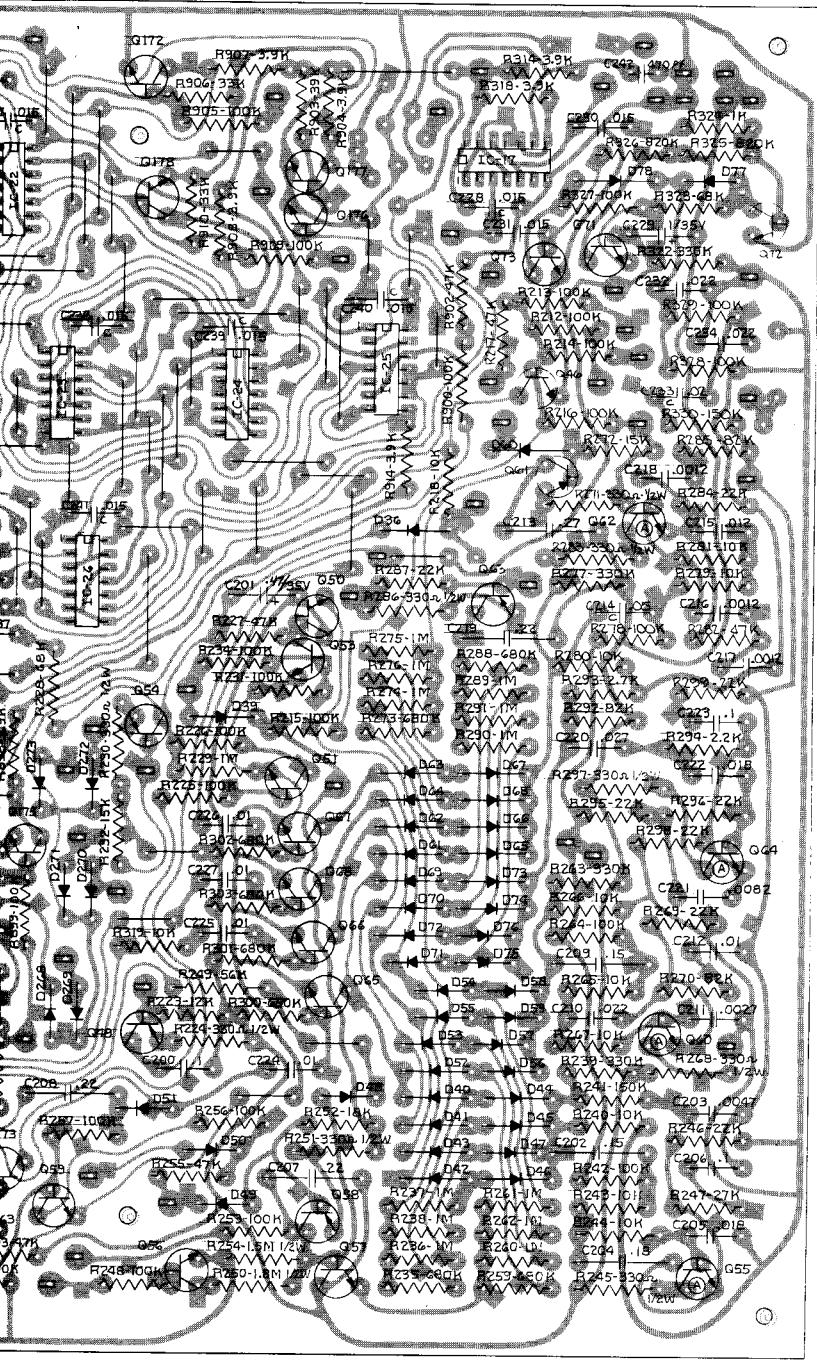

ITEM	QTY	PART NO.	PART NAME
70	X	53134-6	SOLDER-IRON
69	X	5184-3	SOLDER-DIP
68	X	5137-4	WIRE #22 BARE CU
67			
66	L	5294-35-105-2	CAPACITOR TANT 35V 20% 1μf
65	I	5294-35-474-1	" " " 35V 10% .47μf
64	I	5205-153	CAPACITOR CERAMIC .015μf
63	I	5218-503	" " " .05 μf
62	I	5205-203	" " " .02 μf
61	I	5205-471	" " " 470PF
60			
59	I	5232-01-274	CAPACITOR MYLAR .27μf
58	3	5232-01-224	" " " .22μf
57	1	5232-01-184	" " " .18μf
56	2	5232-01-154	" " " .15μf
55	3	5232-01-104	" " " .1μf
54	1	5232-01-273	" " " .27μf
53	3	5232-01-223	" " " .22μf
52	2	5232-01-183	" " " .18μf
51	1	5232-01-123	" " " .12μf
50	5	5232-01-103	" " " .10μf
49	1	5232-01-822	" " " .082μf
48	1	5232-01-472	" " " .047μf
47	1	5232-01-272	" " " .27μf
46	3	5232-01-122	" " " .12μf
45	2	5232-01-153	" " " .15μf
44	1	5233-185	RESISTOR 1/2W 10% 1.8M
43	1	5233-155	" " " 1.5M
42	9	5233-331	" " " 330Ω
41	1	5233-271	" " " 270Ω
40	1	5250-100041Z	RESISTOR 1/4W 5% 4.7K
39	1	5250-XXX	RESISTOR 1/4W 5% SELECT
38	13	5250-105	" " " 1M
37	2	5250-824	" " " 820K
36	8	5250-684	" " " 680K
35	2	5250-474	" " " 470K
34	4	5250-334	" " " 330K
33	1	5250-184	" " " 180K
32	2	5250-154	" " " 150K
31	30	5250-104	" " " 100K
30	3	5250-823	" " " 82K
29	2	5250-683	" " " 68K
28	1	5250-563	" " " 56K
27	8	5250-473	" " " 47K
26	13	5250-333	" " " 33K
25	2	5250-333	" " " 33K
24	1	5250-273	" " " 27K
23	8	5250-223	" " " 22K
22	1	5250-183	" " " 18K
21	2	5250-153	" " " 15K
20	1	5250-123	" " " 12K
19	19	5250-103	" " " 10K
18	1	5250-682	" " " 6.8K
17	16	5250-332	" " " 3.3K
16	2	5250-222	" " " 2.2K
15	1	5250-222	" " " 2.2K
14	14	5250-102	" " " 1K
13	1	A507-059127	MONUMENTON WAFER HT ANGLE 9
12	4	A507-059125	MONUMENTON WAFER HT ANGLE 6
11	2	A514-063882	I.C. 3 INPUT NAND GATE
10	1	A514-059463	I.C. 2 INPUT NAND GATE
9	1	A514-059465	I.C. 2 INPUT NOR GATE
8	1	A514-054489	I.C. DUAL JK FLIP FLOP
7	1	A514-053464	I.C. GUARD Z INPUT NAND GATE
6	1	A514-063227	I.C. TRANSISTOR ARRAY GMPN
5	13	A514-060021	I.C. HEX INVERTER
4	6	A514-044910	TRANSISTOR PNP 5M SIGNAL
3	23	A514-033338	TRANSISTOR NPN 5M SIGNAL
2	158	A514-042731	DIODE MEDIUM VOLTAGE

DATE 10-11-76
 DRAWN D. PEHLE
 CHECKED
 APP'D M/S BA
 FINISH
 REVISIONS
 PART NAME: ASSY F.M. LOGIC BD.
 BALDWIN PIANO & ORGAN CO. CINCINNATI, OHIO
 P 0500-100766

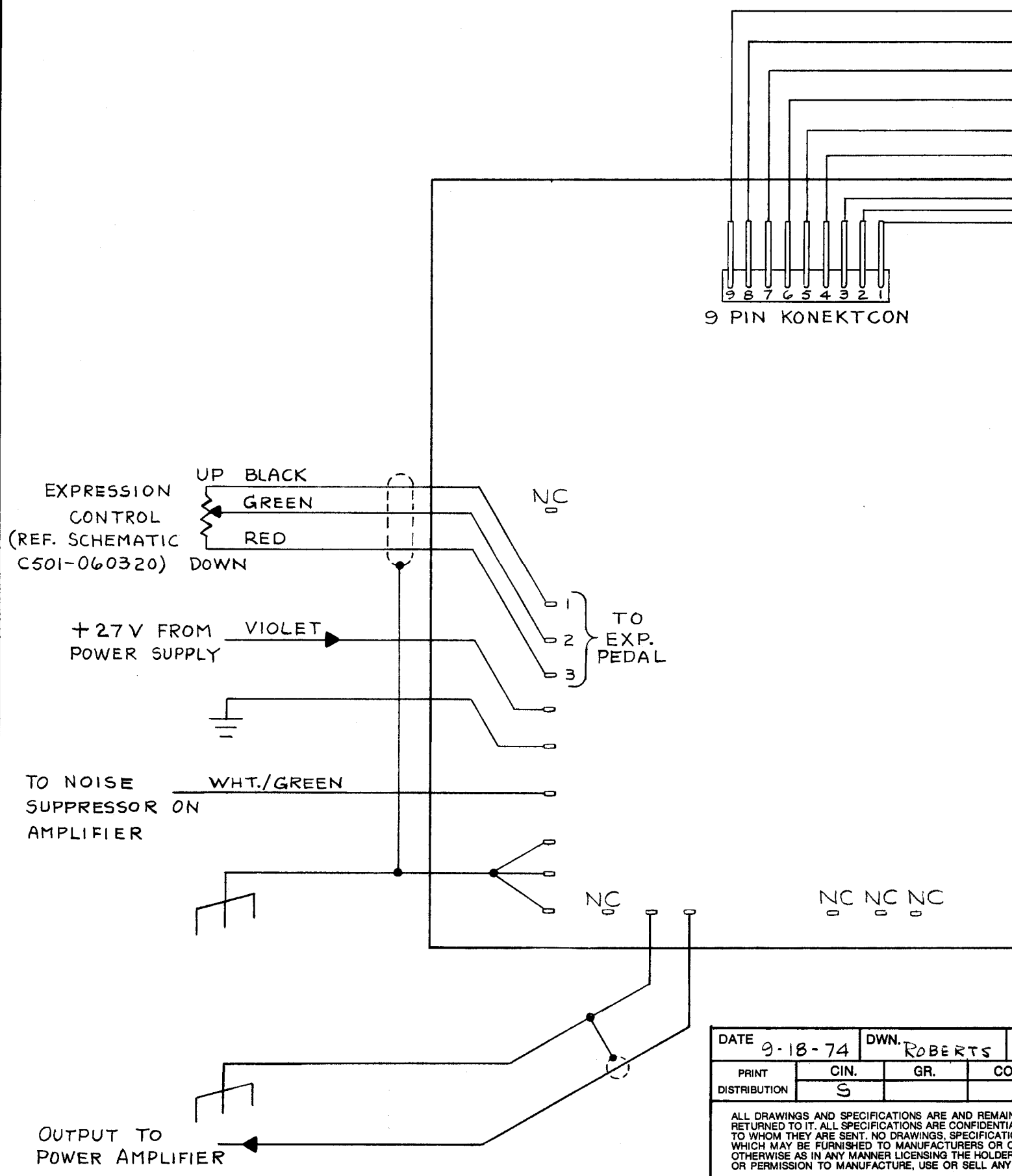

9 PIN KONEKTCON

EXPRESSION CONTROL
(REF. SCHEMATIC C501-060320)

UP BLACK
GREEN
RED
DOWN

NC

TO EXP. PEDAL

+27V FROM POWER SUPPLY VIOLET

TO NOISE SUPPRESSOR ON AMPLIFIER

WHT./GREEN

NC

NC NC NC

OUTPUT TO POWER AMPLIFIER

DATE	9-18-74	DWN.	ROBERTS
PRINT DISTRIBUTION	CIN. S	GR.	CO

ALL DRAWINGS AND SPECIFICATIONS ARE AND REMAIN RETURNED TO IT. ALL SPECIFICATIONS ARE CONFIDENTIAL TO WHOM THEY ARE SENT. NO DRAWINGS, SPECIFICATIONS WHICH MAY BE FURNISHED TO MANUFACTURERS OR OTHERWISE AS IN ANY MANNER LICENSING THE HOLDER OR PERMISSION TO MANUFACTURE, USE OR SELL ANY

UNLESS OTHERWISE SPECIFIED TOLERANCE

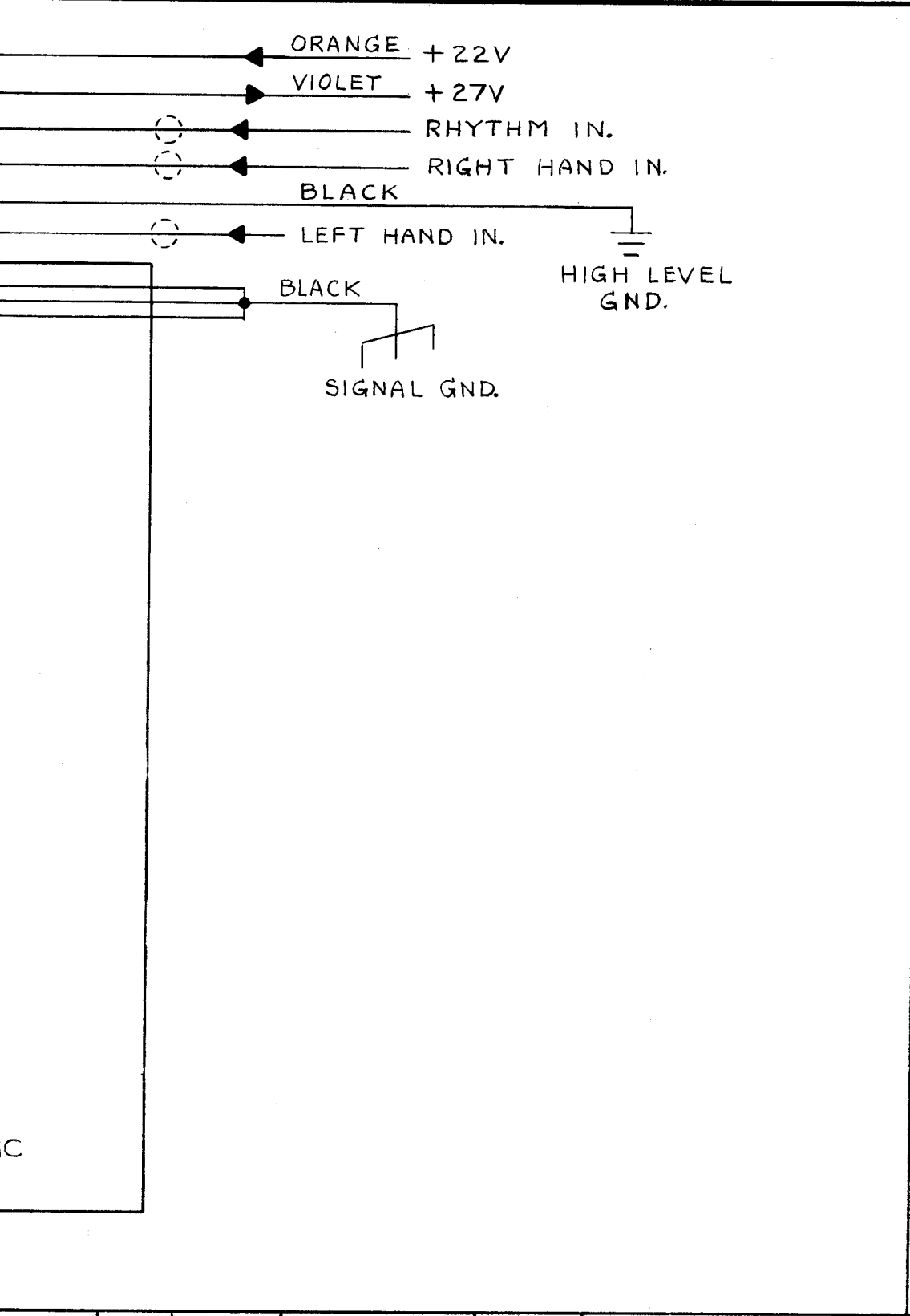

RELEASED

Ord. No. R.N. 650
Date 1/16/74

RECORD OF CHANGE

A) REDRAWN -
NO C.N. H.C.R. 9-18-74

B) REMOVED UNNECESSARY WIRING
C.N. 17864 3/24/78 WB

BERTS	CHK'D	APP'D.	DWN.SCALE	USED ON	PART NAME
R.	CON.	FAY.	FULL	MOD. 121	PREAMP BOARD
		X		REQ. —	PIN WIRING DIAGRAM
		X		FINISH —	B/M503-121-10 GR. NOTE IT.
ARE AND REMAIN THE PROPERTY OF THE BALDWIN PIANO & ORGAN CO. AND MUST BE ARE CONFIDENTIAL AND ARE NOT TO BE DISCLOSED TO ANY PERSONS OTHER THAN THOSE NGS, SPECIFICATIONS OR OTHER DATA BELONGING TO THE BALDWIN PIANO & ORGAN CO. FACTURERS OR OTHERS FOR ANY PURPOSE ARE TO BE REGARDED BY IMPLICATION OR SING THE HOLDER OR ANY OTHER PERSON OR CORPORATION OR CONVEYING ANY RIGHTS SE OR SELL ANY PATENTED INVENTION THAT MAY IN ANY WAY BE RELATED THERETO.				NEXT ASSEM.	SUPERSEDES B501-06044B
ED TOLERANCES ARE: DECIMAL ± .005 FRACTIONAL ± .015 ANGLE ± 1/2°				BALDWIN PIANO & ORGAN CO. CINCINNATI, OHIO	B 501-060448 B

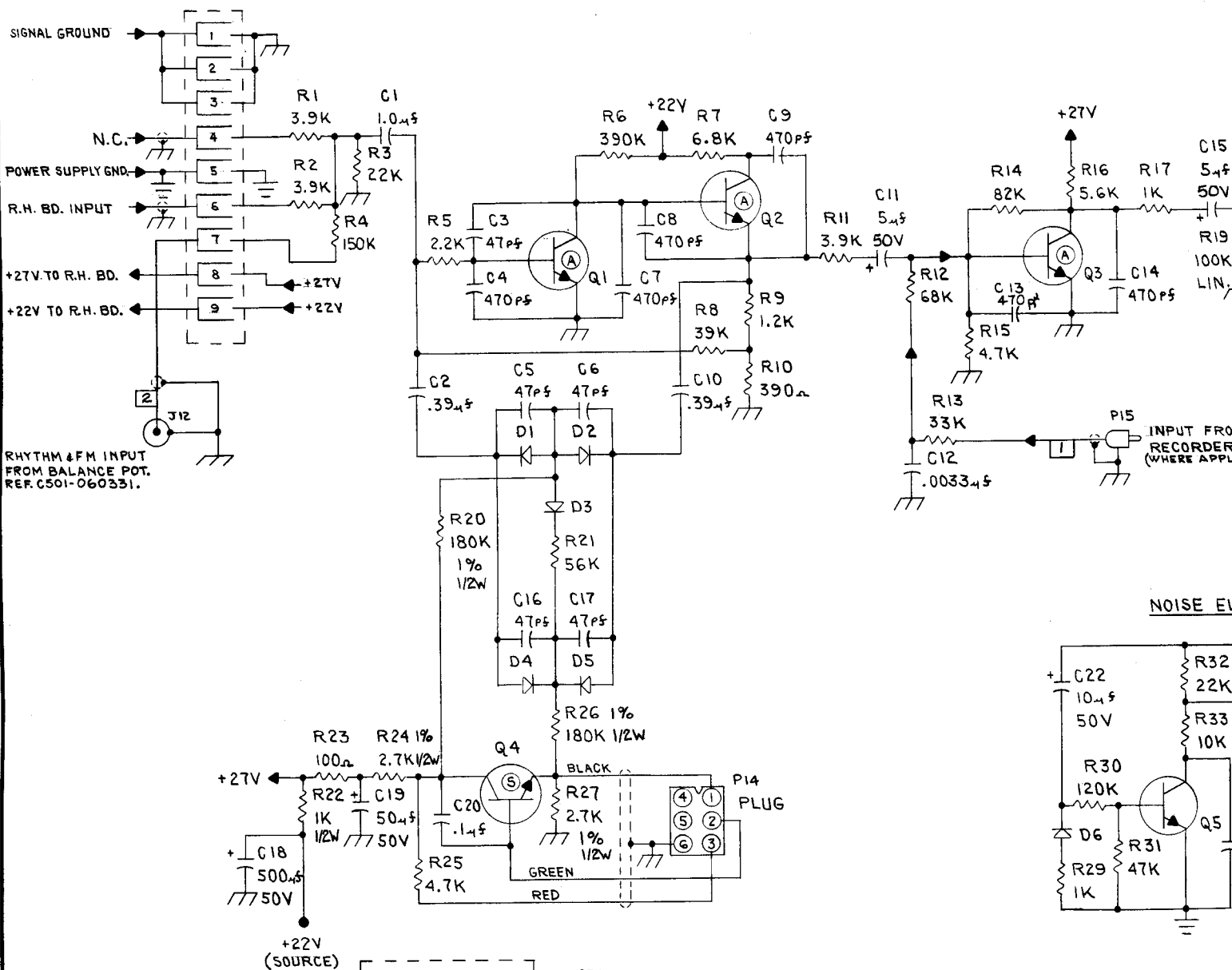

NOTES:

1. SELECT NPN TRANSISTORS I
2. BRIDGE DIODES D1, D2, D4 &
3. ALL RESISTORS ARE 1/4 W
4. D.C. VOLTAGE MEASURMEN (VOLT OR HIGHER) FROM

DATE	1-14-74	DWN.	D. DIEHL
PRINT	CIN.	GR.	
DISTRIBUTION	S		
LAST USED	R34	C23	Q6
	D6		

ALL DRAWINGS AND SPECIFICATIONS ARE AND BE RETURNED TO IT. ALL SPECIFICATIONS ARE CONSIDERED TO WHOM THEY ARE SENT. NO CHANGES, SPECIFICATIONS WHICH MAY BE FURNISHED TO MANUFACTURERS, OTHERWISE AS IN ANY MANNER LICENSED THE MANUFACTURER TO MANUFACTURE, USE OR SELL. UNLESS OTHERWISE SPECIFIED TOLERANCE

RELEASED

Ord. No. R.N. 650
Date 1/31/74

RECORD OF CHANGE

- A) R4 WAS 82K RESISTOR
C.N. 15,760 M.S. 2-27-74
- B) R22 WAS 2.7K
C.N. 17,118 2-4-77 RH
- C) DELETED C21
C.N. 17864 3/24/78 WB
- D) REVISED NOTE 3
REVISED C11, & C15
C.N. 17962 6-2-78 RHM

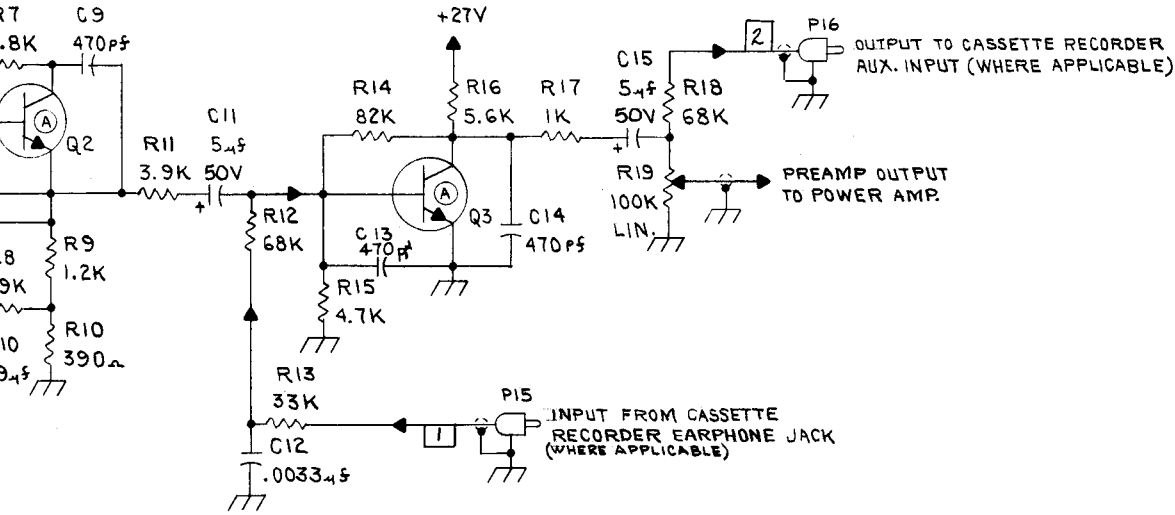

NOISE ELIMINATOR

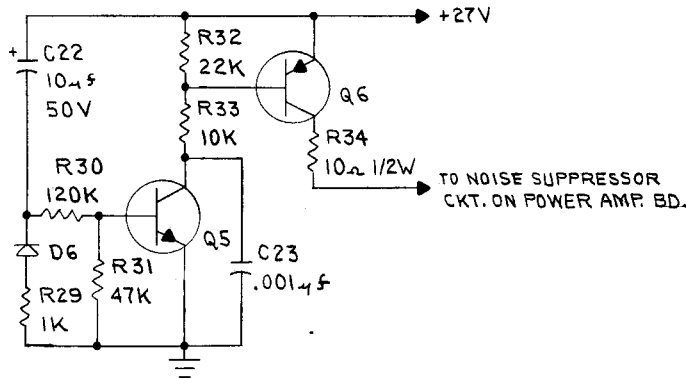

NOTES:

1. SELECT NPN TRANSISTORS PER S429- AS INDICATED.
2. BRIDGE DIODES D1, D2, D4 & D5 PER S440-1.
3. ALL RESISTORS ARE 1/4 W UNLESS OTHERWISE SPECIFIED.
4. D.C. VOLTAGE MEASUREMENTS TAKEN WITH A VOLTMETER (20,000 OHM PER VOLT OR HIGHER) FROM POINT INDICATED TO GROUND.

DATE 1-14-74	DWN D. DIEHL	CHD. <i>Dmd</i>	APPD. <i>Rdk</i>	DWN SCALE	USED ON 121W	PART NAME	
PRINT DISTRIBUTION	CHN.	GR.	CON.	PAY.	DEQ.	E. P. T.	
LAST USED	S			38L-1BR	58L		
R34	ALL DRAWINGS AND SPECIFICATIONS ARE AND REMAIN THE PROPERTY OF THE BALDWIN PIANO & ORGAN CO. AND MUST BE RETURNED TO IT. ALL SPECIFICATIONS ARE CONFIDENTIAL AND ARE NOT TO BE DISCLOSED TO ANY PERSONS OTHER THAN THOSE TO WHOM THEY ARE SENT. NO DRAWINGS, SPECIFICATIONS OR OTHER DATA BELONGING TO THE BALDWIN PIANO & ORGAN CO. WHICH MAY BE FURNISHED TO MANUFACTURERS OR OTHERS FOR ANY PURPOSE ARE TO BE REPRODUCED BY REPLICATION OR OTHERWISE AS IN ANY MANNER LICENSING THE HOLDER OR ANY OTHER PERSON OR CORPORATION OR CONVEYING ANY RIGHTS OR PERMISSION TO MANUFACTURE, USE OR SELL ANY PATENTED INVENTION THAT MAY IN ANY WAY BE RELATED THERETO.					FINISH	RAM 503-121-10 GR. NOTED IT.
C23	UNLESS OTHERWISE SPECIFIED TOLERANCES ARE: DECIMAL $\pm .005$ FRACTIONAL $\pm .016$ ANGLE $\pm .1^\circ$					NEXT ASSY.	SUPERSEDES
Q6	BALDWIN PIANO & ORGAN CO. CINCINNATI, OHIO					C	501-060320
D6							D

RELEASED
 C.N. 670
 8/13/76
 RECORD OF CHANGE

REVISED NOTE 1:
 70mV (±5mV) WAS 50mV
 (±15mV) AND 70mV (±10mV)
 WAS 50mV (±20mV).
 ADDED NOTE B
 C.N. 11592 10-31-77 J7M3
 R23 & R31 WERE 15K,
 R25 & R33 WERE 200Ω,
 R26 & R35 WERE .47K.
 (FUSE WIRE)
 C.N. 17174 2-1-78 J7M3

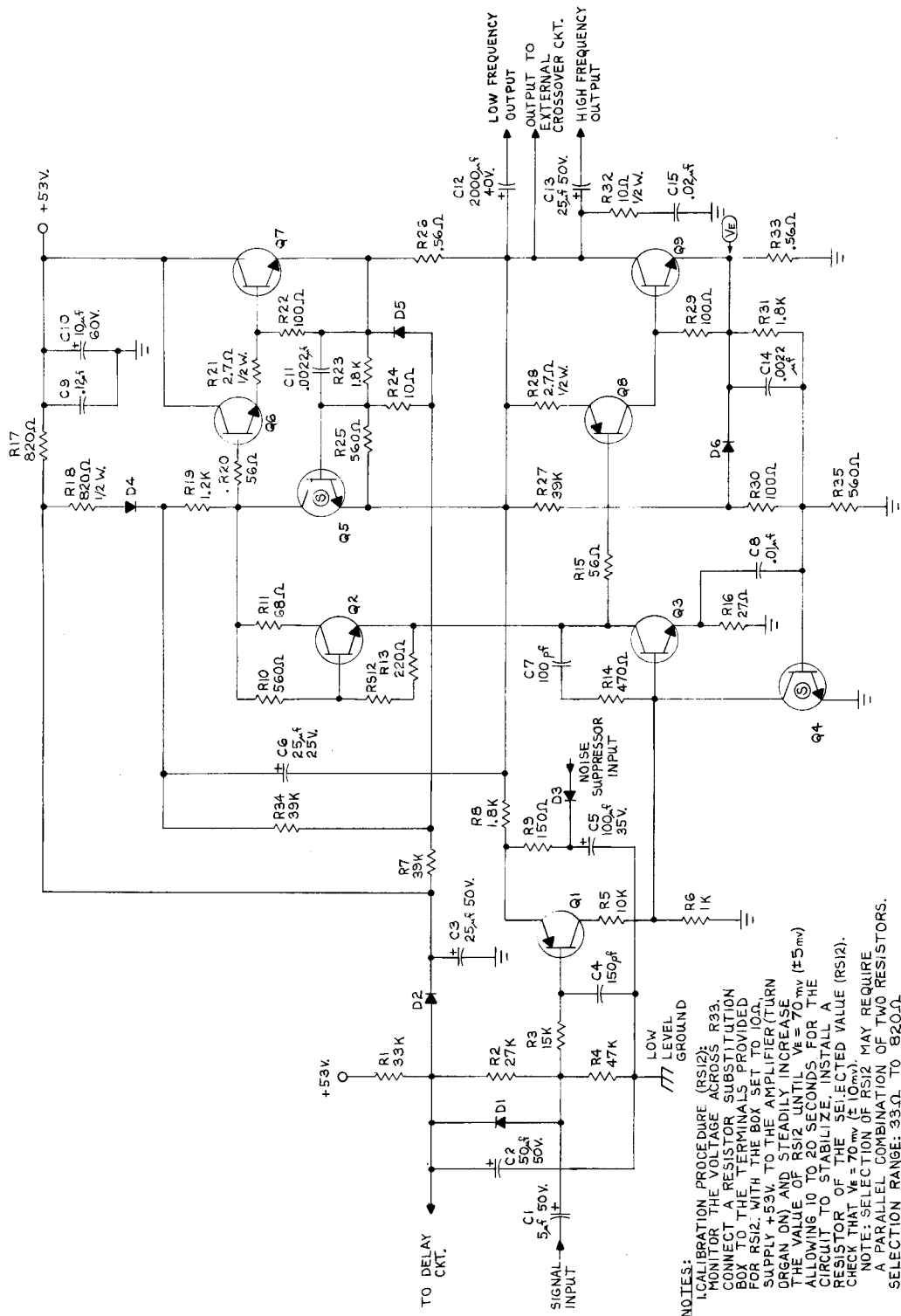

NOTES:
 1. CALIBRATION PROCEDURE (RS12):
 MONITOR THE VOLTAGE ACROSS R33.
 CONNECT A RESISTOR SUBSTITUTION
 BOX TO THE TERMINALS PROVIDED
 FOR RS12. WITH THE BOX SET TO 10Ω,
 SUPPLY +53V. TO THE AMPLIFIER (TURN
 ORGAN ON) AND STEADILY INCREASE
 THE VALUE OF RS12 UNTIL $V_e = 70\text{ mV} (\pm 5\text{ mV})$
 ALLOWING 10 TO 20 SECONDS FOR THE
 CIRCUIT TO STABILIZE. INSTALL A
 RESISTOR OF THE SELECTED VALUE (RS12).
 CHECK THAT $V_e = 70\text{ mV} (\pm 10\text{ mV})$.
 NOTE: SELECTION OF RS12 MAY REQUIRE
 A PARALLEL COMBINATION OF TWO RESISTORS.
 SELECTION RANGE: 33Ω TO 820Ω

- CALIBRATION MUST BE CHECKED, AND ADJUSTED
 IF NECESSARY, WHENEVER ANY TRANSISTOR
 IS REPLACED.
- ALL RESISTORS ARE 1/4 WATT, 5% UNLESS
 OTHERWISE SPECIFIED.
- SELECT NPN TRANSISTORS Q4, Q5 PER S429-2
- DC VOLTAGE MEASUREMENTS TAKEN WITH A
 VOLTMETER (2000 OHMS PER VOLT OR HIGHER)
 FROM POINT INDICATED, TO GROUND.
- ALL GROUNDS ARE HIGH LEVEL GROUNDS
 UNLESS OTHERWISE INDICATED.

- TRANSISTORS:
 PNP SMALL SIGNAL (A514-044910)-Q1
 PNP MEDIUM POWER (A514-047829)-Q8
 NPN SMALL SIGNAL (A514-033338)-Q2, Q4, Q5
 NPN MEDIUM POWER (A514-047828)-Q3, Q6
 NPN POWER (A514-054214)-Q7, Q9 WITH HEAT SINKS
- REF ASSY C0500-100447.

DATE	BY	APP'D	CHK'D	USED ON	PART NAME
4-15-76	D. STEVENSON	R.A.L.	R.M.A.	ORGANS	SCHEM 25 WATT AMPLIFIER
	CON	FAY	3 B/L	FINISH	BAM 803-133-10 GR. NOTE
	GR	2 B/L	1 B/L	REWORK	SUPERSEDES
	GR	3 B/L	1 B/L	REWORK	
	GR	3 B/L	1 B/L	REWORK	

UNLESS OTHERWISE SPECIFIED TOLERANCES ARE: DECIMAL: ±.03 FRACTIONAL: 1/16 ANGLE: 2:1

ALL DIMENSIONS AND SPECIFICATIONS ARE THE PROPERTY OF THE BALLWIN TRANS & ORGAN CO. AND MUST BE KEPT IN CONFIDENCE. NO PART OF THIS DOCUMENT IS TO BE REPRODUCED OR TRANSMITTED IN ANY FORM OR BY ANY MEANS, ELECTRONIC OR MECHANICAL, INCLUDING PHOTOCOPYING, RECORDING, OR BY ANY INFORMATION STORAGE AND RETRIEVAL SYSTEM, WITHOUT THE WRITTEN PERMISSION OF BALLWIN TRANS & ORGAN CO.



BALLWIN TRANS & ORGAN CO.
 CINCINNATI, OHIO

C 0501-100455 B

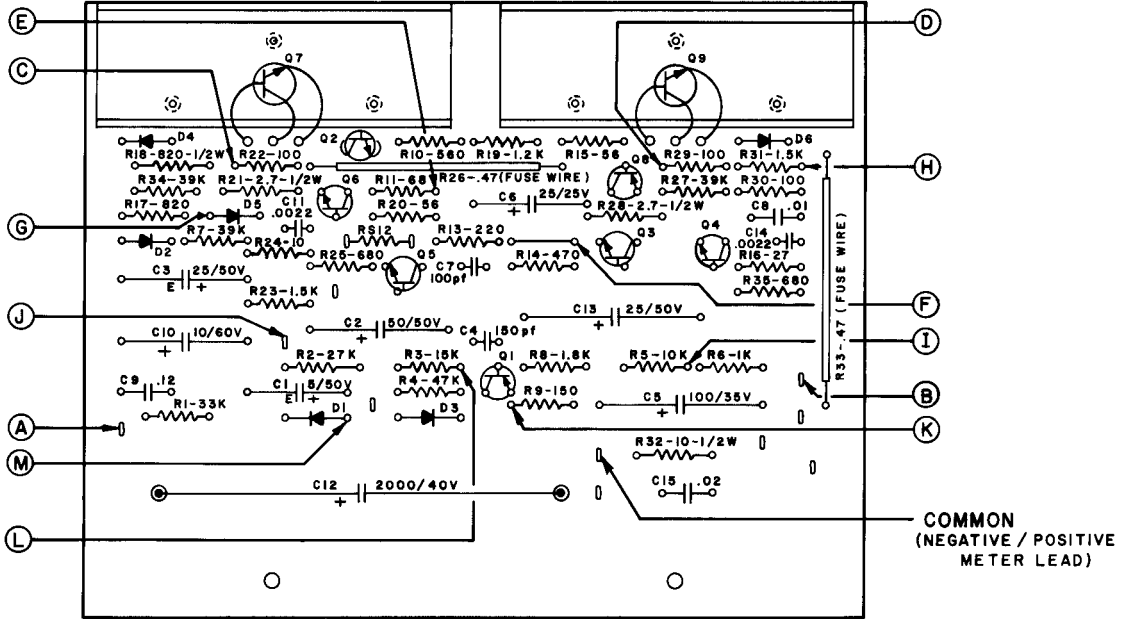
25W AMPLIFIER BD. ASSY. C0500-100447, SCHEM. # C0501-100455



	A	B	C	D	E	F	G	H	I	J	K	L	M
CORRECT READING	3K/520	525/37K	100/100	500/37K	1.1K/870	2.5K/850	440/450	1K/37K	1.8K/37K	25K/23K	1.7K/1.7K	53K/4K	35K/22K
Q1C-E SHORT		-/9.5K		-/9.5K				-/9.5K	1.6K/9K		1.5K/1.6K	-/3.9K	
Q1C OPEN									1.9K/-			-/4.2K	
Q2C-E SHORT					-/820	1.1K/800							
Q3C-E SHORT	8K/-	-/770		-/800	920/-	550/750		-/1.5K	-/2.5K	23K/-		-/3.8K	
Q3C OPEN						-/950							
Q4C-E SHORT						-/810			520/35K				
Q5C-E SHORT	4.5K/-				0/0	850/700			1.6K/-	7.5K/-		43K/-	26K/-
Q5C OPEN					-/2K	-/870							
Q6C-E SHORT	100/100				1K/850	2.4K/-				2K/21K		31K/3.7K	5.5K/1.8K
Q6C OPEN	10K/-									23K/-			
Q7C-E SHORT	0/0					2.3K/-						31K/3.7K	5K/-
Q7C OPEN	-/340									-/27K			
Q8C-E SHORT		100/100		0/0		-/820		550/550	900/850			-/3.5K	
Q8C OPEN					-/850	-/925							
Q9C-E SHORT		0/0		100/100		-/800		440/440	750/700			-/3.5K	
Q9C OPEN		5K/-		5K/-				6K/-	6K/-				
D1 SHORT										-/18K		42K/-	24K/20K
D1 OPEN										-/26K		63K/-	50K/-
D2 SHORT										2.7K/1.5K		42K/3.8K	25K/16K
D2 OPEN										45K/-		70K/-	
D4 SHORT	1K/-				1K/850	2.4K/-				3.7K/-		47K/-	26K/-
D4 OPEN	34K/-									40K/-		75K/-	50K/-
D5 SHORT					-/800		0/0						
D5 OPEN							750/∞						
D6 SHORT								625/-					
R26 OPEN	7.5K/3K		2.2K/1.7K		4K/940	5.5K/-	650/660			26K/-			
R33 OPEN		3K/-		-/39K		-/910		2K/-	3.5K/-				

- NOTES:
1. READINGS MADE WITH ALL CONNECTING LEADS DISCONNECTED.
 2. THIS TROUBLESHOOTING CHART CAN ALSO BE USED FOR 50W AMP. BD. ASSY. D0500-100453, EXCEPT THE CORRECT READINGS WILL BE SLIGHTLY LOWER.
 3. MEASUREMENTS TAKEN WITH "SIMPSON 260" 20kΩ/V USING RX100 FOR RESISTANCES UP TO 10kΩ AND RX10,000 ABOVE 10kΩ FROM DESIGNATED LETTER TO COMMON.
 4.  DESIGNATES SAME AS CORRECT READINGS.
 DASH DESIGNATES READING SAME AS CORRECT.
 X/Y
 X-READING MADE WITH (-) METER LEAD TO COMMON.
 Y-READING MADE WITH (+) METER LEAD TO COMMON.

POWER AMPLIFIER TROUBLESHOOTING CHART

NOV. 2, 1977
 DWN. *[Signature]*
 CHD. *[Signature]*

MODEL 121
PARTS LIST

For the Model and Serial Number Nameplate location, refer to Figs. 3 & 14.

Information pertaining to the case finish and factory installed accessories is coded into the model and serial number. For this reason, and because of possible changes in sub-assemblies during the normal production life of an instrument, the complete model and serial number must be supplied when ordering replacement parts for a particular instrument.

MODEL AND SERIAL NUMBER CODE

FOR THE 121 SERIES ORGAN

SERIES CODE

MODEL	121FC	SERIAL NO.	01234
-------	-------	------------	-------

Model Number

Sequential Serial Number designation

SERIES CODE

C _{Note}	WITH CASSETTE TAPE PLAYER/RECORDER
W	WITH FUN BASS

NOTE: Cassette factory installation only. No longer available.

MODEL 121 PARTS LIST

GENERATOR ASSEMBLY

PART NUMBER	DESCRIPTION
0500-060640	Top Octave Frequency Generator Board Assembly
0500-060130	Gate & Divider Board Assembly.....
0514-061735	I.C. - 7 Stage Frequency Divider - in Line.....
0514-060260	Top Octave Frequency Generator (Mostek)
0514-047801	IC - Frequency Divider - Staggered Leads.....
0512-060328	Coil Assembly - Vertical Mounting
0514-033338	Transistor - NPN
0514-044910	Transistor - PNP
0514-042791	Diode - Medium Voltage
0514-033903	Diode - 100 V
0507-059132	IC Socket
0507-060591	IC Nest - 11 Connector
0507-060150	IC Nest - 8 Connector
0507-059125	Interconnect - 6 Connector
0507-059127	Interconnect - 9 Connector
0211-015500	Capacitor, 500 mfd @ 15 V
0211-025050	Capacitor, 50 mfd @ 25 V
0211-025010	Capacitor, 10 mfd @ 25 V
0411-001102	Capacitor, Poly .001 mfd @ 100 V
0411-001223	Capacitor, Poly .022 mfd @ 100 V
0244-204752	Capacitor, Tant. 4.7 mfd
0244-252251	Capacitor, Tant. 2.2 mfd
0205-000102	Capacitor, Ceramic .001 uf
0205-000103	Capacitor, Ceramic .01 uf
0205-000203	Capacitor, Ceramic .02 uf
0218-000104	Capacitor, Ceramic .1 uf
0232-001102	Capacitor, Mylar .0010 uf
0232-001122	Capacitor, Mylar .0012 uf
0232-001152	Capacitor, Mylar .0015 uf
0232-001182	Capacitor, Mylar .0018 uf
0232-001222	Capacitor, Mylar .0022 uf
0232-001272	Capacitor, Mylar .0027 uf
0232-001332	Capacitor, Mylar .0033 uf
0232-001392	Capacitor, Mylar .0039 uf
0232-001472	Capacitor, Mylar .0047 uf
0232-001562	Capacitor, Mylar .0056 uf
0232-001682	Capacitor, Mylar .0068 uf
0232-001822	Capacitor, Mylar .0082 uf
0232-001103	Capacitor, Mylar .010 uf
0232-001123	Capacitor, Mylar .012 uf
0232-001153	Capacitor, Mylar .015 uf
0232-001183	Capacitor, Mylar .018 uf
0232-001223	Capacitor, Mylar .022 uf
0232-001273	Capacitor, Mylar .027 uf
0232-001333	Capacitor, Mylar .033 uf
0232-001393	Capacitor, Mylar .039 uf
0232-001473	Capacitor, Mylar .047 uf
0232-001563	Capacitor, Mylar .056 uf
0232-001683	Capacitor, Mylar .068 uf
0232-001823	Capacitor, Mylar .082 uf
0232-001104	Capacitor, Mylar .10 uf
0232-001124	Capacitor, Mylar .12 uf
0232-001154	Capacitor, Mylar .15 uf
0232-001184	Capacitor, Mylar .18 uf
0232-001224	Capacitor, Mylar .22 uf
0232-001274	Capacitor, Mylar .27 uf
0232-001334	Capacitor, Mylar .33 uf
0232-001394	Capacitor, Mylar .39 uf
0232-001474	Capacitor, Mylar .47 uf
0232-001564	Capacitor, Mylar .56 uf
0232-001684	Capacitor, Mylar .68 uf
0232-001824	Capacitor, Mylar .82 uf
0232-001105	Capacitor, Mylar 1.0 uf
0514-061735	Frequency Divider
0514-061891	Dip Socket - 16 Conn.
0514-061890	Dip Socket - 14 Conn.
0516-061235	Wire Wrap Post

MODEL 121 PARTS LIST

POWER SUPPLY - AMPLIFIER-PREAMP

<u>PART NUMBER</u>	<u>DESCRIPTION</u>
0500-060603	Power Supply Board Assembly
0500-060514	25 Watt Amplifier Assembly
0500-060447	Preamp Board Assembly
0240-015020	Resistor - 20W - 15 Ohm
0240-050120	Resistor - 20W -500 Ohm
0240-010020	Resistor - 20W - 10 Ohm
0240-030105	Resistor - 5W -300 Ohm
0240-7R5-05	Resistor - 5W - 7.5 Ohm
0517-039382	Capacitor, Electrolytic 25 mfd @ 50 V
0517-051652	Capacitor, Electrolytic 2000 uf @ 40 V
0211-025500	Capacitor, Electrolytic 500 uf @ 25 V
0211-075250	Capacitor, Electrolytic 250 uf @ 75 V
0211-050100	Capacitor, Electrolytic 100 uf @ 50 V
0211-025100	Capacitor, Electrolytic 100 uf @ 25 V
0211-015100	Capacitor, Electrolytic 100 uf @ 15 V
0211-050050	Capacitor, Electrolytic 50 uf @ 50 V
0211-025050	Capacitor, Electrolytic 50 uf @ 25 V
0211-025025	Capacitor, Electrolytic 25 uf @ 25 V
0211-025005	Capacitor, Electrolytic 5 uf @ 25 V
0211-050500	Capacitor, Electrolytic 500 mfd @ 50 V
0211-050010	Capacitor, Electrolytic 10 mfd @ 50 V
0218-000104	Capacitor, Ceramic .1 uf
0218-000503	Capacitor, Ceramic .05 uf
0205-000203	Capacitor, Ceramic .02 uf
0205-000103	Capacitor, Ceramic .01 uf
0205-000102	Capacitor, Ceramic .001 uf
0205-000472	Capacitor, Ceramic .0047 uf
0205-000471	Capacitor, Ceramic 470 pf
0205-000151	Capacitor, Ceramic 150 pf
0514-054214	Transistor - NPN - Power
0514-047828	Transistor - NPN - Medium Power
0514-047829	Transistor - PNP - Medium Power
0514-033338	Transistor - NPN - Silicon
0514-044910	Transistor - PNP - Silicon
0514-038984	Rectifier - Silicon
0514-035596	Rectifier - Silicon
0514-047970	Diode - Zener - 8.2 V
0514-042791	Diode - Signal - Medium Voltage
0528-051906	Heat Sink
0528-051905	Heat Sink
0244-047994	Shoulder Washer
0507-033322	Transistor Socket
0514-033359	Insulator - Mica
0244-047992	Spacer
0514-033375	Fuse Wire
0237-051596	Capacitor Mounting Clip
0509-041912	Minipot - 100K - Linear
0507-059127	Konektion - 9 Connector
0516-061235	Wire Wrap Post

FUN MACHINE BOARDS

0500-060698	Fun Machine Board Assembly
0500-060470	Rhythm Section Voice Board Assembly
0500-060479	Fun Machine Logic Board Assembly
0500-060663	Right Hand Board Assembly
0514-033338	Transistor - TRN3
0514-044910	Transistor
0514-047829	Transistor - Medium Power
0514-042791	Diode - Medium Voltage
0509-041912	Minipot - 100K
0514-053981	IC Operational Amp - Rhythm
0514-059739	IC R.O.M. #3 - Rhythm
0514-058249	IC Rhythm Counter - Rhythm
0514-060021	IC - Type 7405 - Fun Machine
0514-059464	IC - Type 7403 - Fun Machine
0514-054489	IC - Type 74107 - Fun Machine
0507-059127	Wafer Interconnector - 9 Pin
0507-059125	Wafer Interconnector - 6 Pin

MODEL 121 PARTS LIST

FUN MACHINE BOARDS

<u>PART NUMBER</u>	<u>DESCRIPTION</u>
0507-059132	IC Socket
0507-060150	IC Socket Nest - 8 Connector
0507-060149	IC Socket Nest - 12 Connector
0514-061891	Dip Socket - 16 Conn.
0514-061894	Dip Socket - 24 Conn.
0502-061038	F.M. Cover
0516-061235	Wire Wrap Post
0232-001102	Capacitor, Mylar .0010 uf
0232-001122	Capacitor, Mylar .0012 uf
0232-001152	Capacitor, Mylar .0015 uf
0232-001182	Capacitor, Mylar .0018 uf
0232-001222	Capacitor, Mylar .0022 uf
0232-001272	Capacitor, Mylar .0027 uf
0232-001332	Capacitor, Mylar .0033 uf
0232-001392	Capacitor, Mylar .0039 uf
0232-001472	Capacitor, Mylar .0047 uf
0232-001562	Capacitor, Mylar .0056 uf
0232-001682	Capacitor, Mylar .0068 uf
0232-001822	Capacitor, Mylar .0082 uf
0232-001103	Capacitor, Mylar .010 uf
0232-001123	Capacitor, Mylar .012 uf
0232-001153	Capacitor, Mylar .015 uf
0232-001183	Capacitor, Mylar .018 uf
0232-001223	Capacitor, Mylar .022 uf
0232-001273	Capacitor, Mylar .027 uf
0232-001333	Capacitor, Mylar .033 uf
0232-001393	Capacitor, Mylar .039 uf
0232-001473	Capacitor, Mylar .047 uf
0232-001563	Capacitor, Mylar .056 uf
0232-001683	Capacitor, Mylar .068 uf
0232-001823	Capacitor, Mylar .082 uf
0232-001104	Capacitor, Mylar .10 uf
0232-001124	Capacitor, Mylar .12 uf
0232-001154	Capacitor, Mylar .15 uf
0232-001184	Capacitor, Mylar .18 uf
0232-001224	Capacitor, Mylar .22 uf
0232-001274	Capacitor, Mylar .27 uf
0232-001334	Capacitor, Mylar .33 uf
0232-001394	Capacitor, Mylar .39 uf
0232-001474	Capacitor, Mylar .47 uf
0232-001564	Capacitor, Mylar .56 uf
0232-001684	Capacitor, Mylar .68 uf
0232-001824	Capacitor, Mylar .82 uf
0232-001105	Capacitor, Mylar 1.0 uf
0211-025001	Capacitor, 1 uf @ 25 V
0211-025005	Capacitor, 5 uf @ 25 V
0211-025010	Capacitor, 10 uf @ 25 V
0211-025050	Capacitor, 50 uf @ 25 V
0211-025100	Capacitor, 100 uf @ 25 V
0244-354741	Capacitor, Tantalum .47 uf
0244-356841	Capacitor, Tantalum .68 uf
0244-351052	Capacitor, Tantalum 1 uf
0244-252251	Capacitor, Tantalum 2.2 uf
0205-000330	Capacitor, Ceramic 33 pf
0205-000101	Capacitor, Ceramic 100 pf
0205-000471	Capacitor, Ceramic 470 pf
0205-000102	Capacitor, Ceramic .001 uf
0205-000222	Capacitor, Ceramic .0022 uf
0205-000103	Capacitor, Ceramic .01 uf
0205-000203	Capacitor, Ceramic .02 uf
0218-000503	Capacitor, Ceramic .05 uf
0218-000104	Capacitor, Ceramic .1 uf

MODEL 121 PARTS LIST
EXPRESSION PEDAL ASSEMBLY

<u>ITEM NO.</u>	<u>PART NUMBER</u>	<u>DESCRIPTION</u>
454- 1	D-500-053250	Expression Pedal Assembly
454- 2	A-500-044740	Potentiometer Lever Assembly
454- 3	A-506-044842	Bushing
454- 4	B-509-048890	Potentiometer - 50K
454- 5	A-526-035985	Drive Spring
454- 6	A-526-051773	Kickplate Spring
454- 7	A-237-033321	Expression Pedal Spacer
454- 8	C-244-022513	Pedal Pad
454- 9	A-525-034469	Vinyl Extrusion - 5 Inch
454-10	A-247-040149	Spring Washer
454-11	A-247-031746	"E" Ring
454-12	A-244-036416	Nylon Shim
454-13	A-244-040842	Rubber Bumper
454-14	A-247-022975	Elastic Stop Nut

KEYCAP ASSEMBLIES

454-15	X-500-060086	Center Keycap Assembly
454-16	X-500-060085	Bass Keycap Assembly
454-17	X-500-060084	Treble Keycap Assembly
454-18	A-511-048788	Capacitor Assembly - .47 uf @ 400V
454-19	A-514-059254	Light Emitting Diode
454-20	A-514-058969	L.E.D. Assembly
454-21	A-247-058982	Knob Assembly - Tempo
454-22	A-247-060067	Knob Assembly - Vibrato
454-23	A-247-060398	Knob Assembly - Drum Balance - Pull Off
454-24	A-506-058601	Power Switch
454-25	B-506-060078	Push Button Switch - 6 Station
454-26	B-509-040783	Potentiometer - 100K - Linear
454-27	B-059-048340	Potentiometer - 100K - Linear & Switch
454-28	B-509-047956	Potentiometer - 5K - Linear
454-29	A-528-060052	Potentiometer Mounting Plate
454-30	A-250-054568	Switch Button - Insert Type
454-31	A-247-054867	Push Button Insert - Blue
454-32	A-247-047794	Knob
454-33	A-249-058946	Knob Insert - Tempo
454-34	A-249-060065	Knob Insert - Vibrato
454-35	A-249-060397	Knob Insert - Drum Balance - Pull Off
454-36	A-247-060079	Plasti-Grommet
454-37	A-247-052812	Spacer

MODEL 121 PARTS LIST
MANUAL AND SWITCH ASSEMBLY

PART NUMBER	DESCRIPTION
0500-060339	Manual Assembly
0500-060340	Switch Assembly
0500-060487	Keyslip Assembly with Actuator
0244-052672	Actuator Bar Gasket
0500-060236	Phone Jax Assembly
0507-038438	Phone Jax Only
0250-060054	Natural Key Assembly - C
0250-060055	Natural Key Assembly - D
0250-060056	Natural Key Assembly - E
0250-060057	Natural Key Assembly - F
0250-060058	Natural Key Assembly - G
0250-060059	Natural Key Assembly - A
0250-060060	Natural Key Assembly - B
0250-060061	Natural Key Assembly - Wide C
0250-060062	Sharp Key Assembly
0250-041044	Natural Keycap - C req. 4
0250-041045	Natural Keycap - D req. 4
0250-041046	Natural Keycap - E req. 4
0250-041047	Natural Keycap - F req. 4
0250-041048	Natural Keycap - G req. 4
0250-041049	Natural Keycap - A req. 4
0250-041050	Natural Keycap - B req. 4
0250-041051	Natural Keycap - Wide C req. 2
0250-025895	Sharp Keycap
0250-054321	Key Channel Assembly
0247-035550	Fibre Washer
0244-023942	Key Bumper
0244-040842	Bumper for Actuator
0247-052681	Speed Nut
0237-052680	Actuator Detent
0506-052616	Micro Switch
0244-006344	Felt
0244-054730	Keyslip Felt
0244-010008	Felt - Brown
0244-028487	Felt - 3/8" x .160/.180"
0244-024941	Felt - Maroon - 5/16" x .240/.260"
0244-006211	Felt - Maroon - 1/4" x .035/.050"
0502-060050	Switch Cover
0506-031977	Switch Plunger - 2 Slot
0506-027595	Contact Wire - 50 req.
0244-019857	Neoprene Washer
0506-024323	Spacer - .187
0247-053663	Switch Post Washer
0506-060141	12 Note Switch Board Assembly
0506-060140	13 Note Switch Board Assembly - W.C. 1 req.
0506-060139	13 Note Switch Board Assembly ... 1 req.
0506-032723	13 Note Header Bar 2 req.
0506-031910	12 Note Header Bar.....
0500-031585	13 Note Plunger Guide Assembly . . . 2 req.
0500-031584	12 Note Plunger Guide Assembly . . . 2 req.
0500-052666	Actuator Bar.....
0506-031576	Spacer - .125
0528-022466	Upstop Bar C - E
0528-023045	Upstop Bar F - C
0528-022465	Upstop Bar F - E

MODEL 121 PARTS LIST

CONTROL PANEL ASSEMBLY

<u>PART NUMBER</u>	<u>DESCRIPTION</u>
0500-063750	Key Selector Switch Assembly with Cables
0500-060175	Control Panel and Extrusion Assembly
0500-060176	Control Panel Assembly
0500-060177	Channel Extrusion Assembly
0500-060163	Rhythm Section No. 1 Control Switch Assembly
0500-060157	Rhythm Section No. 2 Control Switch Assembly
0500-060248	Soloist's Section No. 1 Control Switch Assembly
0500-060266	Soloist's Section No. 2 Control Switch Assembly
0506-047925	Push Button Switch - 9 Station (Rhythm Section)
0506-060316	Push Button Switch - 6 Station (Soloist's Section) ...
0250-054568	Push Button - Insert Type
0247-054867	Push Button Insert - Blue
0247-054868	Push Button Insert - Red
0247-054869	Push Button Insert - Clear
0514-042791	Diode - Medium Voltage
0507-059127	Konekteon - 9 Connector
0507-059125	Konekteon - 6 Connector
0514-060529	Fluorescent Lamp Starter FS-4
0514-060528	Fluorescent Lamp - 30 Watt
0507-060525	Fluorescent Lamp Socket
0507-035085	Closed End Connector.....
0507-060524	Starter Base - Socket
0237-061345	Compression Ring
0247-052812	Spacer
0244-060716	Grille Cloth
0244-060450	Grille Cloth
0249-060518	Lumalite Panel Rev B.....

MISCELLANEOUS

0093-060011	Foot
0105-060167	Music Desk Panel
0247-060205	Propeller Nut - 1/4" - 20
0247-060221	Adjustment Swivel Glide - 1/4" - 20
0249-060527	Nameplate - Minor Bar
0513-054664	Speaker - 6"
0513-024925	Speaker - 12"
0512-053438	Transformer
0517-038985	Capacitor, 4000 mfd @ 60V
0514-060522	Ballast 120 - 60 Hz Robertson S40B
0514-059976	Fuse Holder.....
0514-032101	Fuse - 2 Amp - Slo-Blo
0514-061031	Mylar Insulator
0502-060595	Preamp Shield
0502-060050	Switch Cover
0508-027658	Power Cord
0237-060230	Recessed Bumper.....
0518-052823	Trim Molding
0507-035085	Closed End Connector
0507-027654	Solderless Disconnect - Single
0507-028288	Solderless Disconnect - Double
0175-060250	Back Panel
0160-060493	Bench Assembly
0244-060450	Grille Cloth - Per Foot
0506-058921	Power Switch - Rocker Type - Red (Export Only)
0512-054035	Power Transformer - 120/240 V - 50/60 Hz (Export Only)
0512-059907	Power Transformer - 100 V PRI (Export Only)
0508-049363	Power Cord - 3 Conductor - #18 (Export).....
0514-060995	Ballast - Fluorescent Lamp - 220V - 50 Hz (Export).....
0514-060994	Ballast - Fluorescent Lamp - 118 V 50 Hz (Export).....
0514-060996	Ballast - Fluorescent Lamp - 220 V - 60 Hz Brazilia ..
0507-044885	Socket - 3 Pin - Molex
0507-044886	Plug - 3 Pin - Molex
0507-044897	Socket - 6 Pin - Molex
0507-044898	Plug - 6 Pin - Molex

MODEL 121 PARTS LIST

MISCELLANEOUS

<u>PART NUMBER</u>	<u>DESCRIPTION</u>
0507-044874	Socket - 9 Pin - Molex
0507-044875	Plug - 9 Pin - Molex
0507-044876	Socket - 12 Pin - Molex
0507-044877	Plug - 12 Pin - Molex
0507-042637	Socket - 15 Pin - Molex
0507-042705	Plug - 15 Pin - Molex
0516-046569	Terminal - Female - Small
0516-042630	Terminal - Female - Large
0516-046572	Terminal - Male - Small
0516-042635	Terminal - Male - Large
0507-027654	Solderless Connector - Single.....
0507-028288	Solderless Connector - Double
0507-035841	Solderless Connector- Speaker
0507-014682	Phono Plug
0507-060473	Extension Jax
0507-059124	Harness Connector - Konekteon - 6 Connector
0507-059126	Harness Connector - Konekteon - 9 Connector
0516-059123	Terminal - Konekteon - Crimp Style
0528-060546	Recorder Mounting Bracket
0500-060874	Cassette Drawer Assembly
0500-052185	Cassette Player/Recorder
0508-061214	Cassette Input Cable
0512-048333	AC Adapter
0160-060493	Bench Assembly
0237-021646	KD Clamp (Bench)
0247-060221	Adjustable Swivel Glide
0237-061791	Clamp (Bench)
S2064-3S	Bench Nuts (sq. nuts 5/16 - 18).....
0514-063062	Slow Blow Fusetron, 2. Amp
0528-060165	Lid Support Bracket.....
0528-060037	Manual Support Bracket - Treble
0528-060036	Manual Support Bracket - Bass
2239-001010	Screw for Glide

CASE

0160-060493	Final Assembly
0164-060461	Leg Assembly
0162-060474	Lid Assembly

MODEL 121W PARTS LIST

GENERATOR

Refer to 121 Section For Parts Not Listed Here

<u>DRAWING NUMBER</u>	<u>DESCRIPTION</u>
0500-103520	Board, Assembly Gate & Divider
0500-102983	Board, Assembly Top Octave Frequency
3257-163229	Capacitor, Electrolytic 2.2 uf @ 63V

POWER SUPPLY, AMP, PREAMP

0500-102873	Board, Assembly Power Supply
0500-100447	Board, Assembly Amplifier - 25 Watt
0500-102975	Board, Assembly Amplifier - 25 Watt
0232-001105	Capacitor, Mylar 1.0 mfd @ 100V
0232-001394	Capacitor, Mylar .39 mfd @ 100V
0232-001332	Capacitor, Mylar .0033 mfd @ 100V
0232-001104	Capacitor, Mylar .1 mfd @ 100V
0211-035100	Capacitor, Electrolytic 100 mfd @ 35V
0240-7R5010	Resistor 7.5 Ohm @ 10 Watt
0121-000015	Resistor 150 Ohm @ 2 Watt

MANUAL & SWITCH PARTS

0500-100747	Manual, Assembly - Final
0500-100835	Board, Assembly Touch Strip Interface - Final
0500-102964	Board, Assembly Touch Strip Interface - Final
0500-100690	Touch Strip Assembly
0528-100819	Keyslip
0249-100839	Nameplate - Minor Touch
0247-101649	Palnut - #4-40
0500-100615	Board, Assembly Touch Strip Interface
0514-033903	Diode - High Voltage

KEYCAPS

0500-100760	Keycap, Assembly - Center
0500-100749	Keycap, Assembly - Bass
0500-100944	Keycap, Assembly - Treble
0500-103315	Switch, Assembly Keyselector
0247-100764	Knob, Assembly Fun Bass
0244-100820	Vinyl Leather
0528-100819	Keyslip
0506-100666	Switch, Pull Up
0250-102115	Knob - Without Insert
0249-100763	Insert - Fun Bass
0244-100303	Button, Plug

CONTROL PANEL ASSEMBLY

Acrylic Effective 1/12/79, Serial #59877	
0247-103132	Insert, Push Button - Blue - Acrylic
0247-103131	Insert, Push Button - Red - Acrylic
0247-103128	Insert, Push Button - Dot - Acrylic
0247-103129	Insert, Push Button - White - Acrylic
0250-102115	Knob, Push Button - Acrylic
0244-100820	Vinyl Leather
0247-100811	Insert, Push Button - Dotted

FUN MACHINE BOARD ASSEMBLY

0500-100750	Unit, Assembly Fun Machine
0500-100231	Board, Assembly Rhythm Voice
0500-102971	Board, Assembly Rhythm Voice
0500-103072	Board, Assembly Rhythm Voice
0500-100766	Board, Assembly Logic
0500-102979	Board, Assembly Logic
0500-102981	Board, Assembly Right Hand
0500-103352	Board, Assembly Right Hand
0502-102013	Cover, Fun Machine Assembly

MODEL 121 PARTS LIST

CASE

<u>PART NUMBER</u>	<u>DESCRIPTION</u>
0060-060012	Lid, Assembly
0090-060026	Side, Assembly - Treble
0090-060027	Side, Assembly - Bass
0244-100920	Cloth, Grille

MISCELLANEOUS

0244-100920	Grille Cloth Panel - Precut
0249-100831	Nameplate - Baldwin
2265-8-4SCPL	Screw #8 E.H. Type"17" 1/2" Long
0237-102078	Clip Component
0525-102298	Extrusion, Board Printed Circuit



TECHNICAL MANUAL SUPPLEMENT

MODEL 121 TECHNICAL MANUAL

PROBLEM: Addition of external amplification to the Model 121F "FUN MACHINE".

SOLUTION: At the terminal on the preamp board designated: "output to cassette recorder", the preamp output signal is available. Make connection, using shielded wire, at the terminals indicated in the illustration. The signal level at this point is sufficient to drive a power amplifier directly, such as an organ tone cabinet. If an organ tone cabinet is to be used, an adaptor must be built which will supply A.C. power to the tone cabinet. The installing technician can choose one of several possible methods of supplying power to the tone cabinet used. Such as a direct A.C. line input to pins 1 and 6 of the 6 pin power connector on Baldwin tone cabinets for temporary installations; or for a more permanent installation, switched A.C. is available at the "FUN MACHINE" power transformer primary.

If a guitar amplifier is to be used, an additional series resistor should be added to drop the signal output level of the "FUN MACHINE" to make it compatible with the guitar amplifier input level requirements. If a very large value resistor is used, it may be desirable to add a capacitor across the series resistor to restore the high frequencies which will be rolled off by the resistor. Due to the wide range of amplification equipment which can be used for this purpose, some experimentation by the installing technician will be necessary to determine optimum component values.

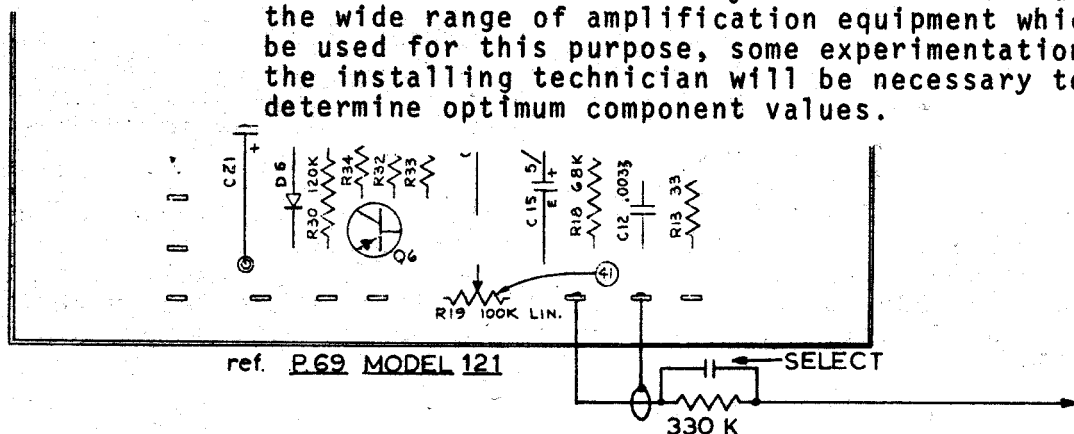

TM121-1-G571



TECHNICAL MANUAL SUPPLEMENT

Suppression of RF Interference
In Model 121, 127, & 128 Organs

Tech Manual Page

Modifications

121 127 128

57 73 81
 or
 132

On the FunMachine Logic Board, add a 1K ohm resistor in series with the base and add a 470pf capacitor directly between base and emitter of transistors Q55, Q60, Q62, & Q64.

60 76 78

On the Right Hand Voice Board (FunMachine), add a 1K ohm resistor in series with the base and add a 470pf capacitor directly between base and emitter of transistors Q74, Q75, Q76, & Q79.

60 76 78

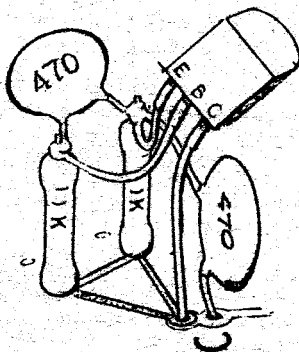

In the Right Hand Output Amplifier on the Right Hand Voice Board (FunMachine), remove existing RF bypass capacitors C446 and C447 (470pf). Add 1K ohm resistors in series with both the base and the emitter of Q83. Add a 470pf capacitor directly between the base and emitter and between the collector and emitter of Q83. Add a 150pf capacitor in parallel with 47K ohm feedback resistor, R516.

- 79 75
 or
 129

In the Left Hand Output Amplifier on the Left Hand Voice Board (FunMachine), modify the Q130 circuit in the same manner as described above for Q83. Note: in the Model 128 series, the Q132 circuit must also be modified.

- - 150

On the Electronic Tremolo Board (128FE only), change R13 and R86 from 10K ohm to 6.8K ohm. Change R14 and R87 from 2.2K ohm to 1.2K ohm and add .0015µf ceramic capacitors in parallel with R14 and R87.

The installation of a line filter in series with the AC power cord can be helpful in reducing local AM standard broadcast interference which is being picked up in the power lines. Use a Cornell-Dubilier filter type APF520L or equivalent. This filter is stocked by the Baldwin Organ Technical Service Department under part number 0579-000508.



TECHNICAL MANUAL SUPPLEMENT

MODEL 121W

Beginning Model 121W, #70848 divider IC's Part #0514-061735 were replaced with 1²L type IC's Part #0514-064032. This change was made to enable usage of more available IC's.

As IC part #0514-064032 does not require -9 volts, the -9 volt supply was eliminated from the Power Supply board (Schematic C0501-060598), and the resistors carrying -9 volts to the IC's were eliminated on the Gate and divider board (Schematic C0501-060143).

If necessary on future repairs on Models 121, 127, and 128 organs, IC #0514-064032 can replace, or be intermixed with, IC #0514-061735 (or #0514-047801 on earlier organs), if the resistors carrying the -9 volts to the replacement IC are removed.